

**BACHELOR OF SCIENCE IN ELECTRONIC AND  
TELECOMMUNICATION ENGINEERING**

**Performance Analysis of FSO Channel System in  
Different weather condition via iterative design with Space Diversity**

**Submitted By**

**Tanbirul Islam**

**Matric ID: T173001**

**Supervised By**

Engr. Abdul Gafur

Associate Professor

Department of ETE

International Islamic University Chittagong

Department of Electronic and Telecommunication Engineering

International Islamic University Chittagong

Kumira, Sitakunda, Chittagong – 4314

August 2023

**Signature Page Sign by Thesis Committee**

## **Certificate of Approval**

The thesis entitled "Performance Analysis of Free-Space Optical (FSO) Channel Based on Different Amplifier Configurations," authored by Tanbirul Islam (student ID: T173001) has been deemed satisfactory in its stylistic presentation and substantive content. This thesis fulfills a partial requirement for attaining the Bachelor of Science degree in Electronic and Telecommunication Engineering (ETE).

---

Supervisor

Engr. Abdul Gafur

Associate Professor

Department of Electronic and Telecommunications Engineering

International Islamic University of Chittagong

## **Declaration of Candidate**

It is now affirmed that the present thesis has been duly finalized, with no portion previously tendered to obtain a degree or certification from any other academic establishment.

---

Tanbirul Islam

Matric ID: T173001

## **Acknowledgement**

By the principles of the Islamic faith, I invoke the name of Allah, the Most Forgiving and the Most Merciful. We express our profound gratitude to the divine entity, Allah (SWT), for allowing us to flourish and graciously manifesting His benevolence throughout our journey. May the blessings and peace of Allah be bestowed upon the esteemed Prophet Muhammad (PBUH), whose profound influence and sagacious counsel continue to serve as a wellspring of inspiration for humanity at large. Respected thesis supervisor, Engineer Abdul Gafur. We express our utmost appreciation and indebtedness for his commendable initiative in study, invaluable guidance, and unwavering encouragement throughout this research endeavour. We extend our utmost gratitude for Engr.'s exceptional amenities and punctual insights. Zahidur Rashid is an esteemed academician serving as an Associate Professor and Chairman of the Department of Electronics and Telecommunications Engineering. The invaluable service the thesis examination committee rendered merits profound acknowledgement in light of their diligent efforts and unwavering commitment. We would like to extend our sincerest congratulations to all of our esteemed educators for their steadfast commitment and diligent efforts over numerous years. Furthermore, we express our profound gratitude to our esteemed progenitors for their invaluable counsel and unwavering assistance bestowed upon us throughout our existence. We would like to express our sincere appreciation to our respected family members, friends, and individuals who have extended their support and assistance in various capacities throughout the completion of this scholarly thesis.

## **Abstract**

We inspected FSO system that has a 10 Gbps data stream. the analysis is monitored for NRZ line codes as a channel we use free-space optics length to establish a high speed optical wireless communication system within 7,4.8 & 2.2 Km length. in this system, we compare different types of configurable amplifier setups these setups smooth our high-speed data rate. We also change our receiver optics aperture which given us more reliable performance. The Free space optics system has to remark a different kind of attenuation problem this type of problem we are looking over in our proposed system to establish the best system. evaluating our proposed system we analyzed Bit error rate data, Quality factor data, eye diagram data. By comparing anyone can get a reliable system to the high capacity access network with more bandwidth cost-effective and good flexibility.

# Table of Contents

Signature Page Sign by Thesis Committee .....	i
Certificate of Approval .....	ii
Declaration of Candidate .....	iii
Acknowledgement .....	iv
Abstract .....	v
Table of Contents .....	vi
List of Figures .....	x
List of tables.....	xii
List of Symbols .....	xiii
List of Abbreviations .....	xv
<b>Chapter 1: Introduction .....</b>	<b>1</b>
1.1 Introduction.....	1
1.2 History of Free Space Optical Network and Optical Amplifier.....	1
1.3 Working principle of FSO Channel for Optical Fiber Communication.....	5
WDM .....	6
DWDM .....	8
Advantage of FSO Channel .....	8
Limitation of FSO system.....	10
Atmospheric Weather Conditions.....	10
1.4 Optimization of Free Space Optics Parameters Using WDM System.....	10
1.4.1 Optical Amplifier.....	13
1.4.2 Power Amplifiers.....	13
Applications of Optical Amplifiers.....	14
Parameters of an optical amplifier include: .....	15

1.4.3 Line Amplifiers.....	16
1.4.4 Preamplifiers.....	17
1.4.5 SOA (Semiconductor Optical Amplifier) .....	18
1.4.6 Erbium Doped Fiber Amplifier.....	20
Advantages of EDFA .....	20
Why Different Amplifier Choose for FSO System.....	21
1.5 Objectives of Research .....	22
1.6 Advantages of Optical Amplifier for FSO System .....	22
1.7 Thesis Outline .....	23
<b>Chapter 2: Literature Review .....</b>	<b>19</b>
2.1 literature Review .....	19
FSO TRANSCEIVER MODULE.....	
<b>Chapter 3: System Model.....</b>	<b>59</b>
System Model .....	59
3.1 Fso system with space diversity with amplifier .....	59
<b>Chapter 4: Result ans Simulation.....</b>	<b>63</b>
4.1 Proposed System performance analyzing using space diversity.....	63
<b>Chapter 5: Conclusion and Future Work.....</b>	<b>68</b>
5.1 Conclusion .....	69
5.2 Achievement .....	69
5.3 Limitation.....	70
References.....	60

## List of Figures

Fig 2.1: How beam transmit through free space channel.....	21
Fig 2.2: Spreading of the transmitted beam in free space between the transmitter and the receiver of an FSO system .....	20
Fig 2.3: Building swaying effect towards an FSO system.....	20
Figure 2.4: NRZ data format.....	22
Figure 2.5 Single stage amplifier noise.....	32
Figure 2.6: EDFA simulation Setup.....	32
Figure 2.7: Basic building block of optical DWDM transmission .....	23
Figure 2.8: Transmitter and Receiver step for FSO .....	31
Figure 3.1: Proposed WDM system with Boost amplifier.....	60
Figure 3.2: Proposed WDM system with Preamplifier.....	61
Figure 3.3: Proposed WDM system with Inline amplifier .....	<b>62</b>
Figure 3.4: 32 channel WDM for Free Space Optic using pre amplifier for previous model .....	62
Figure 3.5: 64 channel WDM for Free Space Optic using Boost amplifier for proposed model.....	63
Figure 3.6: 64 channel WDM for Free Space Optic using Pre amplifier for proposed model .....	
Figure 3.7: 64 channel WDM for Free Space Optic using In_Line amplifier for proposed model.....	
Figure 4.1: Proposed System performance for Q Factor using different amplifier .....	63
Figure 4.2: Proposed System performance in Bit Error Rate using different amplifier ...	64
Figure 4.3: Input spectrum Analyser for Boost amplifier.....	65
Figure 4.4: Input spectrum Analyser for Pre amplifier.....	

Figure 4.5: Input spectrum Analyser for IN-LINE amplifier.....	65
Figure 4.6: Maximum Q factor using Boost optical Amplifier vs previous model .....	66
Figure 4.7: Maximum Q factor using Pre optical Amplifier vs previous model .....	67
Figure 4.8: Maximum Q factor using IN –Line optical Amplifier vs previous model.....	
Figure 4.9: Bit Error Rate using Boost Amplifier vs previous model .....	
Figure 4.10: Bit Error Rate using Pre Amplifier vs previous model .....	
Figure 4.11: Bit Error Rate using In_Line Amplifier vs previous model.....	
Figure 4.12: Calculation results of the proposed system for DWDM-FSO link using boost amplifier.....	
Figure 4.13: Calculation results of the proposed system for DWDM-FSO link using pre amplifier.....	67
Figure 4.14: Calculation results of the proposed system for DWDM-FSO link using In-Line amplifier.....	
Figure 4.15: Maximum Q factor in relation to transmitter aperture diameter for different amplifier.....	
Figure 4.16: Maximum Q factor in relation to the receiver aperture diameter for different amplifier.....	

## List of tables

Table 2.1: system parameter used in this paper .....	19
Table 2.2: System Parameter for this paper .....	22
Table 2.3: System Parameter for this paper .....	26
Table 2.4: Atmospheric weather condition along with value of attenuation .....	29
Table 2.5: Comparison table for proposed & previous model.....	30
Table 2.6: EFDA Characteristic.....	33
Table 2.7: Amplified WDM network output .....	33
Table 2.8: power at the input and output of the fiber.....	19
Table 2.9: Required parameters and Values .....	21
Table 2.10: Simulation Parameter.....	24
Table 2.11: Simulation Parameter.....	25
Table 2.12: FWM vs no of channel for the dispersion of Ops.....	27
Table 2.13: comparison between different techniques.....	28
Table 2.14: power of FWM product .....	34
Table 2.15: Specifications.....	35

## List of Symbols

Hz	Hertz
THz	Terahertz
GHz	Gigahertz
f	Frequency
$\omega$ :	Angular frequency
$\lambda$	Wavelength
$\pi$	Pi
B	Byte
MB	Megabyte
s	Second
ps or s <sup>-1</sup>	Per second
MBps	Megabyte per second
GBps	Gigabyte per second
m	Meter
mm	Millimeter
cm	Centimeter
km	Kilometer
$\mu\text{m}$	Micrometer
nm	nanometer
m <sup>-1</sup>	Per Meter
ms <sup>-1</sup>	Meter per second
cm <sup>-1</sup>	Per Centimeter

g/cm <sup>3</sup>	Gram per centimeter cube
kJ/m	Kilo joule per meter
ps/THz/cm	Per second per terahertz per centimeter
dB/m	Decibel per meter
dB/cm	Decibel per centimeter
dB/km	Decibel per kilometer
%	Percentage
d	Diameter
r	Radius
w	Width
a	Major diameter of ellipse
b	Minor diameter of ellipse
$\eta$	Ellipticity
$\Lambda$ Speed of light	Pitch
°C	Degree Celsius
$\eta$	Ellipticity
a	Major diameter of ellipse
b	Minor diameter of ellipse
W	Watt

## List of Abbreviations

FSO	Free Space Optics
WDM	Wavelength Division Multiplexing
DWDM	Dense Wavelength Division Multiplexing
LED	Light Emitting Diode
TIR	Total Internal Reflection
PRE	Power Amplifier
AMP	Amplifier
SMF	Single Mode Fiber
NHMFL	National High Magnetic Field Laboratory
MOF	Micro-structured Optical Fiber
PM	Polarization Maintaining
0D	Zero-Dimensional
NRZ	Non-return to zero
RZ	Return To Zero
FSO	Free Space Channel
PCF	Photonic Crystal Fiber
3D	Three-Dimensional
MSF	Micro Steel Fiber
MCF	Multi-core Fiber
PGB	Photonic Bandgap
M-TIR	Modified Total Internal Reflection
COC	Cyclic Olefin Copolymers

TFE	Tetra-fluoro-Ethylene
PTFE	Polytetrafluoroethylene
MMA	Methyl Methacrylate
SOA	Semiconductor Optical Amplifiers
EDFA	Erbium Doped Fiber Amplifier
RA	Raman Amplifier
CAPEX	Capital Expenditure
UV	Ultraviolet
PC-PCF	Porous-Core Photonic Crystal Fiber
EML	Effective Material Loss
BER	Bit Error Rate
CL	Confinement Loss
TL	Total Loss
PF	Power Fraction
ESM	Endlessly Single Mode
GVD	Group Velocity Dispersion
FEM	Finite Element Method
PML	Perfectly Matched Layer
X-pol	X-polarization
Y-pol	Y-polarization
PS	Partially Slotted
FS	Fully Slotted
LFM	Localized-function Method

BPM	Beam Propagation Method
FDM	Frequency Division Multiplexing
PDIP	Plastic Dual Inline Package
PWM	Pulse Width Modulation
FDTD	Finite-difference Time-domain
BEM	Boundary Element Method
EWFD	Electromagnetic Wave, Frequency Domain
AFF	Air Filling Fraction
ENZ	Epsilon-Near-Zero
Rx Ap	Receiver Aperture
Tx Ap	Transponder Aperture

# Chapter 1

## Introduction

### 1.1 Introduction

Optical innovation has a notable edge in terms of its features and advantages compared to standard electrical gearbox. The system has a substantial storage capacity and a high data transmission rate. The optical transmission framework has two distinct components, namely a transmitter and a multiplexer. Due to the implementation of Opti-Framework, a comprehensive design and testing solution for contemporary optical networks, the process of designing optical connections at the transmission layer of modern optical networks has become much more streamlined. In the current era of rapidly increasing need for high-speed and uninterrupted connectivity, a strong inclination has emerged to augment or maybe replace the existing RF infrastructure. Free-space optical (FSO) communication systems include many compelling attributes, such as high data transmission rates, unrestricted coverage, signal confidentiality, and cost-effectiveness. Free-space optical communication refers to the transmission of information using optical signals via a medium that is not physically constrained, such as the air. The transmission of information is often facilitated by the use of an unlicensed frequency band operating within the visible or infrared spectrum. Government compounds, then, do not possess any practical use. In contrast to optical fibre connections, Free Space Optical (FSO) communication is often used to gain a competitive advantage in terms of performance. Communication may take place through this medium. The system exhibits a broad bandwidth, a large data transmission capacity, and a rapid connectivity protocol. The primary distinction between free-space optical (FSO) and fiber optic transmission is in the manner in which the optical signal is sent. In FSO, the optical signal is collimated and propagated through the atmosphere to the intended destination, where it is captured by a photo detector. The concept of a fast train refers to a high-speed rail system that is designed to transport passengers at a much faster rate than traditional Super continuum fusion may also be used to build a WDM-FSO system. Various bar divergences, widths of transmitter and collector radio wires, and control topologies are tested within the framework. We will examine many more optical speakers in order to mitigate the constriction impact of the proposed approach.

The most effective strategy is to provide information rapidly. As a result, the framework was developed and evaluated at a data transmission rate of 10 gigabits per second (Gbps). In comparison to current technological breakthroughs, Free Space Optics (FSO) has a wide range of benefits. The FSO framework has a notable benefit in terms of cost-effectiveness and simplicity of deployment when compared to other frameworks. There are many planned alterations that are expected to be relevant to the optical hardware inside a Free Space Optics (FSO) framework. The FSO communication framework is considered a highly innovative technology because to its susceptibility to medium weakening. However, its features and scope of application contribute to its attractiveness. When power is lost, the transmission performance of the Free-Space Optical (FSO) system is impeded by the constriction of its medium. However, a thorough examination and preliminary analysis of the medium might reveal the criteria that should be taken into account before implementing the framework. The development of wavelength division multiplexing (WDM)-based free space optical (FSO) frameworks is underway with the aim of mitigating the impact of congestion. Studies on pre-establishment execution investigations are conducted using models based on this research. Following this, the framework might be relocated. Various methodologies, such as OFDM-FSO and WDM-FSO based frameworks, have emerged as innovative approaches to enhance system performance by enabling high-speed and long-distance capabilities. When various approaches are integrated, it becomes possible to develop new methods, which in turn may advance system design. The imperfections inherent in FSO frameworks may be minimized to the lowest possible extent.

## **1.2 History of Free Space Optical Network and Optical Amplifier**

FSO, or Free Space Optics, has experienced a significant surge in demand and advancements as a prominent remote communication technology over the past decade. The terms "Fiber-less" and "Laser Correspondence" (Lasercom) refer to distinct concepts within the field of Free Space Optics (FSO) technology. Remote Optical Communication (ROC), Fibreless Optical Communication, and Laser Communication (Lasercom). Free Space Optics (FSO) is considered a significant area of expertise within the broadband communication service market. There is a high demand for a direct connection between the transmitter and receiver in a clean air environment. FSO innovations are essentially

comparable to fiber optic transmissions. When considering FSO transmission, it is crucial to take into account the optical aspect. Fiber will be employed to transmit the signal. In order to effectively meet the growing demand for transmission capacity, Free Space Optics (FSO) offers a remarkable alternative solution. It is possible to consider utilizing Free Space Optics (FSO) frameworks as an alternative to optical fiber links in situations where the two lines are either inaccessible or expensive in terms of capital expenditure (CAPEX). FSO innovation offers numerous advantages, such as a substantial data transfer capacity, immunity to electromagnetic interference, absence of range limitations, and a higher transmission rate. A well-balanced, slender optical laser column is employed to transmit digital data from the Free Space Optics (FSO) transmitter to the FSO receiver through the medium of free space. The transmitted data is subsequently processed at the receiving station. The term "view" refers to the ability of the transmitter and recipient to visually perceive each other in real-time. The FSO frameworks can be classified into single-pillar and numerous bar categories. The framework classifications encompass both positive and negative aspects. In an open space, a solitary bar FSO framework is susceptible to dispersion due to atmospheric turbulence caused by significant precipitation or fog. Therefore, it is highly unlikely that the shaft will be delivered to the recipient given these circumstances. In order to enhance the range of opportunities and activities within the local community, several foundational elements can be employed. The advantages of a solitary shaft framework include its simplicity and efficient setup between the transmitter and receiver [1]. The multi-shaft FSO system incorporates a laser beam blending technique to reduce power consumption resulting from air turbulence. Organizations involved in 5G cell backhaul can consider utilizing Free Space Optics (FSO) lines as an alternative to fiber optic cables due to their cost-effectiveness and reduced interference. Our goal is to enhance FSO backhaul networks by implementing an additional millimeter-frequency radio-frequency connection (RF). It is crucial to establish a seamless transition between the primary Free Space Optics (FSO) interface and the secondary Radio Frequency (RF)-FSO connection. This is necessary to ensure uninterrupted network connectivity, especially in situations where air disturbances may disrupt the immediate FSO connection. The RF interface operating in the Millimeter Wave (MMW) spectrum offers inherent properties

that can help maintain network stability. As part of our investigation, we establish fundamental numerical criteria for several performance measures, such as blackout probability and average bit error rate (BER). Based on our findings, it has been determined that the FSO/RF-FSO engineering surpasses a single FSO connection in terms of blackout probability and BER. The blended RF-FSO connection utilizes Enhance, and Forward (AF) transfers with a standard power scaling to interface. When analyzing the irradiance fluctuations in Free Space Optics (FSO) connections, it is important to acknowledge significant atmospheric turbulence. Additionally, one should anticipate the presence of multipath Rayleigh fading when examining the Radio Frequency (RF) link. In order to prevent excessive trading, an initial limit of a single Financial Services Officer (FSO) is established, followed by a second FSO threshold. Remote organizations utilizing 5G technology are expected to heavily rely on free-space optical (FSO) communications. Due to their ease of installation and maintenance, FSO lines present a viable alternative to traditional fiber optic cables for backhaul communication. There is a limitation to the utilization of Free Space Optics (FSO) due to its requirement for a direct line of sight. Additionally, the turbulence in the air has a significant impact on the generation process [2]. Several hybrid standards have been developed to combine the advantages of both radiofrequency (RF) and fiber-optic (FSO) cables. Considering atmospheric conditions, Free Space Optics (FSO) links, for example, exhibit superior data transmission rates compared to Radio Frequency (RF) connections. However, it is important to note that FSO links are also susceptible to signal degradation caused by atmospheric interference. On the other hand, the RF association is highly advantageous for FSO operations due to its ability to operate in various climates and effectively navigate through haze without encountering any issues. In our proposed Free Space Optics (FSO)/Radio Frequency-FSO (RF-FSO) setup, the FSO connection is utilized when the Line-of-Sight (LOS) channel is unobstructed. In any scenario, a reinforcement RF-FSO connection is established to ensure network reliability. This innovation provides a backup connection to address weather-related challenges in areas with uneven terrain and industrial belts where dense fog, clouds or smog often obstruct FSO gearbox lines in the event of a critical FSO connection failure. One of the most significant advancements in communication technology is free space

optical communication (FSO), which offers a high data rate, rapid transmission capacity, unrestricted licensing range, and straightforward implementation. The FSO transmission is facilitated via wireless means. The communication system's effectiveness is reduced due to air interference. As part of this review, an analysis was undertaken to assess the influence of different meteorological factors on the performance of an FSO system. The assessment of signal quality was conducted using various criteria, such as transmission reach, power, and pillar disparity, in FSO-SISO and WDM-FSO frameworks. It is imperative to establish a direct line of sight between the transmitter and the collector without any delay. Complimentary Space Optical correspondence. An optical modulator is employed on the transmitter side of the Free Space Optics (FSO) system to control the information signal prior to its transmission to the receiver through the free space channel using the optical transmitter. The optical receiver on the Free Space Optics (FSO) system's receiving end receives the provided signal. The optical identifier and low-pass channel effectively differentiate and route the incoming signal, accurately transmitting the information stream separately. Both external and internal factors affect the performance of Free Space Optics (FSO) communication. Various climatic conditions such as mist, rainfall, and fog have the ability to alter the visual aspects of the weather. Power outages, network reliability, and internal limitations are essential components of the system [3].

### **1.3 Working principle of FSO Channel for Optical Fiber Communication**

Free space optical (FSO) communication refers to the wireless transmission of data using modified optical beams across empty space, eliminating the need for fiber optics or other optical sources. The fundamental principle remains valid even in contemporary times, as evidenced by the historical use of light (or smoke) signals for information transmission. It is plausible that Graham Chime's photo phone invention may have served as an antecedent to contemporary Free Space Optics (FSO) frameworks. The sound messages were transmitted through the manipulation of solar rays. The advancement of lasers, which are highly powerful and focused light sources, has ushered in a new era of Free Space Optics (FSO) systems. Free-space optical (FSO) systems were primarily developed to facilitate secure long-distance communication, spanning distances of 50 to 1000 kilometers. These systems were specifically designed to establish reliable communication channels between

the Earth and satellites, as well as between satellites and the Earth, during a significant portion of the 1970s and 1980s. Over the past decade, the development of high-speed information transmission lines and their integration within limited physical areas has given rise to a new market for Free Space Optics (FSO). The primary contenders in this market consist of copper link-based systems, RF communication systems, and fiber optic enterprises. Compared to similar remote radio frequency transmissions, the optical carrier (1014–1015 Hz) enables significantly higher transmission speeds.

Nevertheless, the utilization of an optical transporter requires an unobstructed visual connection between the transmitter and receiver, leading to a significantly reduced dispersion of the signal. The organization of most Free Space Optics (FSO) frameworks is typically limited to a range of a few hundred meters to a few kilometers. This characteristic makes them highly suitable for effectively distributing high-capacity networks within a locally restricted area. There is a strong likelihood that FSO can offer efficient Ethernet administration with high transfer speeds to individual residences using this approach. Two key advantages of Free Space Optics (FSO) lines compared to fiber networks are their ease of installation and adaptability. These products offer increased utility, simplified maintenance, and efficient consideration of minor adjustments.

## **WDM**

Wavelength-division multiplexing (WDM) plays a critical role in fiber-optic communications by enabling the multiplexing of optical carrier messages onto a single optical fiber. It is feasible to utilize a singular fiber strand to facilitate both capacity expansion and bidirectional transmission. In wavelength-division multiplexing (WDM) systems, multiplexers and demultiplexers are employed to aggregate and segregate signals. In theory, it is possible to achieve both objectives simultaneously by developing an optical add-drop multiplexer that utilizes the suitable fiber type. Thin-film-coated optical glass Fabry-Pérot interferometers, commonly known as etalons, have been extensively utilized as optical filtering technology for a considerable period of time. Wavelength Division Multiplexing (WDM) networks commonly employ single-mode fiber cables with a diameter of 9 micrometers. Multi-mode fibers with lengths of either 50 or 62.5 meters, commonly known as premises cable, can be effectively employed in certain Wavelength

Division Multiplexing (WDM) configurations. Conventional/coarse wavelength division multiplexing (CWDM) and dense wavelength division multiplexing (DWDM) systems are distinct types of wavelength division multiplexing (WDM) systems, characterized by their wavelength patterns. Silica fibers exhibit a third transmission window (C-Band) capacity of up to eight channels at a wavelength of 1,550 nm. Dense wavelength division multiplexing (DWDM) employs a reduced number of channels, yet they are densely packed together within the same transmission window. The number of channels in a typical system can vary depending on the setup, ranging from 40 channels at 100 GHz to 80 channels at 50 GHz. Ultra-dense wavelength division multiplexing (WDM), for example, can be implemented with a spacing of 12.5GHz and is sometimes denoted as ultra-dense WDM. Due to recent advancements in amplification technologies, such as Raman amplification, the L band has been incorporated into the range of wavelengths that are considered useful..

## **DWDM**

The utilization of a technique known as dense wavelength division multiplexing (DWDM) enables the simultaneous transmission of multiple information streams over a single cable. This proposal presents a viable solution for enhancing the capacity of existing networks without the need for additional fiber deployment. The most commonly employed method for backbone lines is Dense Wavelength Division Multiplexing (DWDM). The wavelengths associated with the transmission of information are spaced at a distance of merely 0.8 nm. However, it is conceivable that a separation of 0.4 nm could be achieved as the frequency increases. Currently, there are also Ultra-Dense Wavelength Division Multiplexing (UDWDM) systems available. These systems utilize gaps with a precision of 0.1 or even 0.2 nanometers. Nevertheless, when spacing values decrease, transmission route components, especially DFB (Distributed Feedback) lasers, become increasingly crucial. DWDM systems have the capability to transmit numerous parallel optical lines, ranging from tens to even hundreds. Dense Wavelength Division Multiplexing (DWDM) is distinguished by its standardized frequency of 193.1 THz. In order to achieve optimal performance, it is imperative that the wavelength remains within a tolerance of no more than 0.16 nm from the normalized wavelength.

### **Advantage of FSO Channel**

1. The utilization of free space optics (FSO) as a versatile networking solution has been found to yield superior data transmission rates when compared to traditional broadband technologies.
2. The installation process is characterized by its simplicity and efficiency, as it can be completed within a time frame of fewer than 30 minutes when implemented in conventional settings.
3. The initial investment is characterized by its modest magnitude.
4. The deployment system at hand is characterized by its simplicity and ease of use. In contrast to prior radio and microwave systems, the current paradigm obviates the necessity for spectrum licensing or frequency coordination among users.
5. The system's security is ensured by its line of sight operation, thereby obviating the necessity for any security system upgrades. It is possible to achieve a data transmission

rate of considerable magnitude, akin to that of optical fibre cables. However, it is worth noting that the error rate remains minimal, and the utilization of an exceedingly focused laser beam allows for the deployment of an unrestricted quantity of Free Space Optical (FSO) links within a designated geographical region.

6. Radiofrequency interference exhibits a high degree of immunity. Electromagnetic and radio-magnetic interference cannot affect the transmission in the FSO link.
7. FSO offers dense spatial reuse.
8. Low power usage per transmitted bit is the merit of the FSO system [8]
9. There is a relatively high bandwidth.
10. Transmission of the optical beam is done in the air. Hence, the message has a speed of light.

### **Limitation of FSO system**

The utilization of a technique known as dense wavelength division multiplexing (DWDM) enables the concurrent transmission of multiple streams of information through a solitary cable. This proposal presents a viable resolution for augmenting the capacity of existing networks without the need for additional fibre deployment. The prevailing technique employed for backbone lines is commonly known as Dense Wavelength Division Multiplexing (DWDM). The intervals between wavelengths that convey information are merely 0.8 nanometers in proximity, and as the frequency increases, it becomes conceivable to achieve a distance of 0.4 nanometers. Presently, there exist Ultra-Dense Wavelength Division Multiplexing (UDWDM) systems as well. These systems utilize nanometer-scale gaps ranging from 0.1 to 0.2 nm. Nevertheless, as the spacing values diminish, the significance of transmission route components, specifically Distributed Feedback (DFB) lasers, becomes increasingly indispensable. DWDM systems have the remarkable capability to transmit a multitude of optical lines in parallel, ranging from tens to even hundreds. The distinguishing feature of Dense Wavelength Division Multiplexing (DWDM) lies in its standardized frequency, precisely set at 193.1 terahertz (THz). In order to achieve peak performance, it is imperative that the wavelength remains within a narrow range, deviating no more than 0.16 nm from the standardized wavelength.

### **Atmospheric Weather Conditions**

In an FSO connection, the transmission medium is the atmosphere. Its decrease is attributed to a variety of factors. Weather variations in the area are most commonly to blame for attenuation. There are some odd meteorological conditions at the link's building location. It is possible to acquire information regarding previous attenuation; in temperate areas, fog and heavy snow are the most common meteorological conditions. The availability of FSO lines in tropical areas is significantly impacted by weather factors including intense rain and haze [5]. Below is a more thorough explanation of a few of the present weather conditions:

When fog is present, optical radiation is significantly diminished. Fog reduces vision and causes reflections and dispersion of light. When fog scattering, often referred to as Mie scattering, takes place, it is primarily an issue of boosting the transmitted power.

Rain attenuation caused by rainfall results in nonselective dispersion. The wavelength being utilized has no bearing on this kind of attenuation. Rain might interfere with laser delivery. Depending on how much rain has fallen, the FSO system may or may not be visible. When it rains hard, a substantial volume of water is produced. When absorbed, diffused, and reflecting, they have the potential to change the characteristics of the optical beam or obstruct its passage.

When haze particles linger in the atmosphere for an extended length of time, the atmosphere is attenuated. In other words, attenuation levels depend on the visibility at the time. When doing FSO system testing, attenuation data may be gathered in two different ways: First, a temporary system was installed and tested at the site, and then the Kim and Kruse model was applied.

Burning substances such as carbon and glycerol produce smoke that may be observed for kilometers. It affects the transmission medium's visibility [6].

Sandstorms are a well-known obstacle to outside connection communication. The size of wind particles is first determined by soil texture, followed by the speed at which the wind must blow for the particles to be blown up.

Cloud layers are a crucial part of this layer and are an essential part of the atmosphere of Earth. Clouds are created when water collects or condenses on top of the Earth's surface. Parts of the optical beam that the Earth sends into space may be entirely blocked by it. It is challenging to calculate the attenuation due to the variety and inhomogeneity of the cloud particles.

G) Snow: Due to their bigger size, snow's larger particles add to the geometric dispersion. The snowflakes scatter like Rayleigh waves.

#### **1.4 Optimization of Free Space Optics Parameters Using WDM System**

The team of engineers successfully devised a cutting-edge unidirectional Wavelength Division Multiplexing (WDM) network. In order to optimize performance, it is imperative to adapt the data rate, power allocation, connection range, and user capacity based on prevailing weather conditions. The degree of signal weakening, known as attenuation,

exhibits varying magnitudes depending on the intensity of precipitation. Specifically, for mild precipitation, the attenuation stands at 6.27 dB/km, while medium precipitation experiences a higher attenuation of 9.64 dB/km. In the case of severe precipitation, the attenuation reaches its peak at 19.28 dB/km. The utilization of the 1550 nm wavelength proves to be highly advantageous in rain and haze applications due to its minimal attenuation. In order to enhance the overall performance of the system, it is imperative to ensure a heightened level of transparency in the modification of settings. This research does not account for the impact of geometric losses. While the connection length may be considered of lesser importance, it is imperative to acknowledge the substantial influence of aperture size, laser power, data rate, and optical amplifier gain on the overall system performance.

The findings suggest that across various categories of rainfall, the optimal data rate of 622Mbps consistently emerges as the most favorable choice. The efficacy of the FSO system can be enhanced in adverse weather conditions by leveraging its shorter link distance and reduced data transmission rate. The comparative analysis of these studies is conducted with respect to parameters such as wavelength, power level, data rate, and connection distance. As the attenuation becomes increasingly vital, the spatial divide between the two points of connection diminishes. As the data rate increases, the spatial proximity of the two devices diminishes. The extent of the connection distance is contingent upon the magnitude of the electrical power. The efficacy of attenuation is diminished as the power output is increased. Nevertheless, numerous establishments dedicated to the preservation of laser safety have implemented regulations regarding the permissible magnitude of power that can be employed. As an illustration, the Laser possesses the potential to inflict harm upon an individual if it were to make direct contact with their ocular organ, specifically at a particular wavelength and intensity threshold. As an illustration, the human eye can experience adverse effects upon direct exposure to a Laser operating within the permissible wavelength and power limits set forth by the International Electro technical Commission (IEC) regulations.

### **1.4.1 Optical Amplifier**

The concept of an optical amplifier appears to refer to a system that enhances an optical signal without the need for conversion into an electrical format. The luminous entity undergoes a magnification process. Optical amplifiers are commonly employed as amplification devices in three distinct types of fiber transmission lines. An optical communication system comprises three essential components: a transmitter, a receiver, and a fiber cable. This intricate ensemble facilitates the seamless transmission of data from one terminal to another. Nevertheless, in order to enhance the signal level, an optical amplifier is strategically positioned between the transmitter and receiver components. This is imperative due to the remarkable characteristic of fiber cables, which exhibit significantly lower attenuation compared to alternative mediums like coaxial cables.

However, in the realm of long-distance communication, the transmission of fiber optic cables necessitates the utilization of signal amplification. To mitigate the occurrence of signal distortion during the transmission process, it becomes imperative to employ the utilization of amplifiers. In the context of elucidating an optical communication system that facilitates the transmission of data through the medium of light via a fiber connection, it is imperative to underscore the indispensability of an amplification unit. The degradation of signal quality along its transmission path can be attributed to a multitude of factors. Hence, the task of extracting the original information from said signal is frequently fraught with difficulties. In the event that an electronic amplifier unit is employed, it becomes necessary to procure additional apparatus for the purpose of converting optical signals into electrical signals, and conversely, electrical signals into optical signals. The velocity of data transmission experiences a deceleration during the course of this operation.

Conversely, the advent of optical amplifiers has rendered this concern obsolete. Optical communication systems rely on the utilization of optical amplifiers to facilitate the transmission of signals over extended distances with enhanced efficiency, while mitigating the adverse effects of attenuation. Given that the optical amplifier harnesses the phenomenon of stimulated emission, it is imperative to generate population inversion, akin to that observed in a laser diode, to facilitate this process. Optical amplifiers and laser diodes possess a striking resemblance in their physical structure, allowing for the

augmentation of solely the input signal in the absence of an optical feedback mechanism. Consequently, the capacity of optical amplifiers to autonomously produce coherent output is constrained, with the availability of transmission in a Free-Space Optical (FSO) system being primarily governed by absorption. The presence of carbon dioxide can potentially lead to the phenomenon of signal absorption.

### **1.4.2 Power Amplifiers**

Power amplifiers serve the purpose of augmenting the intensity of a signal before it is transmitted along the line, thereby extending the transmission range before additional amplification becomes necessary. Before being transmitted through an optical fiber, the optical signal undergoes a transformation in the form of a power amplifier, which enhances its intensity at the output of an optical transmitter. The potential for extending the transmission distance by 100 kilometers or more is contingent upon the optical gain exhibited by the power amplifier as well as the losses incurred by the fiber. As an illustration, it is worth noting that the prevailing DFB lasers employed as optical sources typically exhibit a peak output power of up to two mill watts. Following the deployment of the optical transmitter, the optical signal has the potential to undergo amplification through the utilization of a power amplifier. In the realm of optical transmission, the utilization of booster amplifiers on the transmitter side serves the purpose of augmenting the power level of the transmitted signal or compensating for any losses incurred by the optical components situated between the laser source and the optical fibers. The assemblage of devices encompasses a range of optical components, namely optical couplers, splitters, WDM multiplexers, and external optical modulators.

Alternatively, one could articulate that the signal strength of the transmitter undergoes amplification through the utilization of booster amplifiers, thereby enhancing its potency prior to its transmission through the fiber optic connection. In order to facilitate the transmission across the network, one potential approach would involve the utilization of a more potent transmitter. Typically, the power generated by a laser diode or tunable laser source is relatively moderate, particularly when an external modulator is incorporated. The primary distinguishing characteristic of the booster lies in its exceptional capacity to generate a substantial level of output power with a remarkably high degree of saturation.

In addition, it is imperative for the advocate to offer amplification of data signals that are devoid of any discernible bit patterns. In the realm of wavelength-division multiplexing (WDM) systems, it is imperative to ensure an equitable amplification of every signal across the entire spectrum. The phenomenon of polarization exerts a significant influence on the vast majority of booster amplifiers.

### **Applications of Optical Amplifiers**

- The customary implementations of optical amplifiers encompass the following: An optical amplifier serves the purpose of augmenting the average power of a laser output to elevated levels, thereby facilitating the utilization of a master oscillator power amplifier (MOPA) configuration.
- The system exhibits a remarkable capability to generate exceedingly high peak powers, particularly within the realm of ultrasonic.
- The extraction of stored energy within a brief temporal window facilitates the generation of short pulses.
- The utilization of amplification mechanisms prior to photo detection serves to attenuate detection noise, unless the introduction of amplifier noise is of notable magnitude.
- In the context of optical fiber communications, it is imperative to augment the optical power level between extended fiber sections to mitigate the risk of information degradation due to noise interference.

### **Parameters of an optical amplifier include:**

- The maximum gain is delineated as either an amplification factor or in decibels (dB).
- The saturation power, a parameter intricately linked to the gain efficiency, is of considerable significance in this context.
- the saturated output power, as determined by the pump power applied • the power efficiency and pump power requirements associated with the system • the saturation energy, which represents the energy level at which the system reaches saturation • the duration of energy storage, also known as the upper-state lifetime • the gain

bandwidth, including considerations of the smoothness of the gain spectrum, if applicable

- The noise figure, as well as potentially more intricate noise specifications, are subjects of interest for further examination.
- The sensitivity towards back-reflections
- The amplification capacity in terms of modes, as discussed earlier, encompassing both multimode and single-mode amplifiers.)

### **1.4.3 Line Amplifiers**

In order to proficiently restore the original power level of a signal, the implementation of line amplifiers in strategic locations is utilized along an elongated transmission line. The incorporation of an in-line optical amplifier contributes to the enhancement of the attenuation characteristics exhibited by the fibers within a fiber-optic communication system. The diagram provided below visually represents the application of optical amplifiers as in-line amplifiers, along with the interconnection of the optical transmitter and receiver via a fiber link. The primary goal of an in-line optical amplifier in a wavelength-division multiplexing (WDM) network is to mitigate the adverse consequences of signal losses arising from signal distribution, connection losses, and fiber attenuation.

In a traditional context, one may consider the substitution of an optoelectronic repeater, consisting of a photodiode, timing and shaping circuits, and a laser, with a suitable in-line optical amplifier within an extensive optical fiber communication link. Within the domain of long-distance fiber-optic communication networks, it is feasible to seamlessly link a considerable number of in-line optical amplifiers along the fiber connection. The proposed configuration must guarantee the preservation of system performance throughout the entire wavelength-division multiplexing (WDM) spectrum, notwithstanding the combined influence of amplified spontaneous emission (ASE) noise, dispersion, non-linearity, and stability. To effectively counterbalance the pervasive ASE (Amplified Spontaneous Emission) noise, it becomes paramount to ensure a near-linear progression of optical signal intensity in direct correlation with the extent of the optical fiber connection. The

importance of performance requirements resides in their ability to address the challenges posed by weak input signals, the saturation of output power, and the interference caused by noise. The enhancement of system efficiency greatly relies on the optimization of small-signal performance and effective noise control. The propagation of acoustic emissions produced by a network of interconnected amplifiers will establish a limitation on the overall scope of the system. Given the ever-evolving dynamics of polarization within a network, it becomes crucial to mitigate the inherent polarization dependence of the gain [7]. Furthermore, it is imperative that the in-line amplifier demonstrates optimal performance in simultaneously accommodating multiple wavelength channels. Moreover, it is of utmost importance for the in-line amplifier to exhibit the capability to seamlessly manage the data stream in a manner that is characterized by transparency. This mandates the augmentation of modulation patterns across all data rates, while ensuring minimal loss. Moreover, there is a growing need for minimizing dependence on conventional electrical power usage owing to the prospective implementation of in-line amplifiers beyond the central network offices.

#### **1.4.4 Preamplifiers**

Preamplifiers serve the purpose of amplifying the input signal intensity of the optical receiver, thereby enhancing the sensitivity of the receiver in terms of its ability to detect signals. Distinct skill sets are necessitated for each of the three aforementioned scenarios. Preamplifiers are required to exhibit minimal noise, while power amplifiers and line amplifiers necessitate substantial gain. Furthermore, the application of an optical amplifier can be employed in various manners within a network to compensate for network losses. For instance, it can be utilized in an optical switching node to counteract switch fabric losses. The utilization of an optical amplifier as a preamplifier prior to an optical receiver has yielded significant achievements. Specifically, the sensitivity of direct-detection optical receivers has experienced a remarkable enhancement, primarily attributed to a notable reduction in thermal noise. Furthermore, an additional benefit lies in its potential to compensate for losses incurred during local area network (LAN) distribution. While it is true that a preamplifier can operate well below saturation, it lacks the ability to regulate feedback. An exemplary preamplifier must possess exceptional sensitivity, substantial gain

capacity, and an absence of noise interference. The substandard input signals give rise to notable challenges in performance, primarily manifesting as saturated output power and the presence of noise. The optimization of performance and mitigation of noise in small signals can yield enhanced outcomes. The introduction of supplementary amplifiers into a system will result in a reduction in its overall length, primarily attributable to the presence of noise generated by these amplifiers. In light of the network's stochastic polarization state, it is highly desirable to mitigate the polarization dependency of the gain. The in-line amplifier is tasked with the simultaneous management of multiple wavelength channels. This suggests that the in-line amplifier should possess the capability to amplify all modulation patterns at any given data rate without any noticeable loss, thereby exhibiting the quality of processing the data stream in a "transparent" manner. Given that in-line amplifiers have the potential to be situated beyond the confines of central network offices, there is an increasing imperative to mitigate the consumption of electrical power derived from wall outlets.

#### **1.4.5 SOA (Semiconductor Optical Amplifier)**

The semiconductor optical amplifier (SOA) finds application in a myriad of functions, including but not limited to waveform conversion, signal regeneration, pulse shaping, and power limitation. Due to its remarkable integration and substantial capacity for large-scale production, this technology has garnered considerable acclaim in endeavors that necessitate optimal utilization of space and power resources. SOA has been implemented to varying extents in long-haul, metro, and access optical networks. Taking into consideration the application and demand of Service-Oriented Architecture (SOA), it is evident that each of these form factors is readily accessible. A notable distinction between a Semiconductor Optical Amplifier (SOA) and a semiconductor optical laser resides in the absence of feedback through reflection in the former. The application of an external current induces the electron to transition between energy levels, thereby establishing a transmission medium. The electron, brimming with anticipation, gracefully descends to a lower energy level as it engages in a captivating dance with an incoming photon of a specific frequency. A novel photon is generated, possessing identical attributes to the initial photon, under the exact circumstances. The flow of electrical currents through the pump

serves as a catalyst for the activation of electrons within the active region of the Semiconductor Optical Amplifier (SOA). When an optical signal traverses the active region, the electrons undergo a fascinating process of relinquishing their energy in the form of photons, ultimately returning to their fundamental ground state. By employing stimulated photons that possess a wavelength corresponding to the initial optical signal, it becomes possible to achieve signal amplification. The essential constituents of a Semiconductor Optical Amplifier (SOA) encompass gain, gain bandwidth, saturation output power, and noise. Decibels, also known as dB, serve as the quantifiable metric for the amplification factor employed to enhance the input signal. The optical gain of a semiconductor optical amplifier (SOA) is influenced by the magnitude of the current flowing through it. The augmentation of the optical signal's potency is achieved through the process of gain. The gain-bandwidth parameter serves as an indicator of the frequency range within which amplification is effective. In order to enhance the amplitude of signals spanning a wide range of wavelengths, it is imperative to employ an amplifier possessing a broad gain bandwidth.

### **1.4.6 Erbium Doped Fiber Amplifier**

The present communication elucidates the utilization of an optical repeater apparatus, commonly referred to as an erbium-doped fiber amplifier (EDFA), which serves the purpose of enhancing the amplitude of optical signals traversing a network based on fiber optic technology. As an illustrative example, it is plausible that an optical fiber incorporating the rare earth constituent erbium possesses the capacity to concurrently absorb and emit light of identical frequencies. The fundamental underpinning of erbium-doped fiber amplifier (EDFA) technology resides in the utilization of erbium-doped fiber (EDF). Erbium exhibits a protracted intermediate state transition (at wavelengths of 980 nm or 1480 nm) upon exposure to specific light wavelengths. When experiencing a malfunction, the wavelength range spanning from 1525 to 1565 nm is observed to emit light. Light with a wavelength of 1480 nm has the potential to induce either prompt excitation of optically-pumped Erbium ions into a quasi-stable state or provoke a transient, unstable condition that swiftly transitions into a stable state. Upon attaining a quasi-stable state, the entity in question undergoes decomposition, wherein it emits radiation within the wavelength range of 1525 to 1565 nm, ultimately returning to its ground state.

#### **Advantages of EDFA**

- The erbium-doped fiber amplifier (EDFA) exhibits a commendable level of pump power utilization, surpassing the threshold of 50%.
- The Erbium-Doped Fiber Amplifier (EDFA) exhibits the unique capability of directly and concurrently amplifying an extensive range of wavelengths, surpassing 80 nanometers, within the 1550 nanometer region. This amplification process is characterized by a notably uniform gain across the aforementioned wavelength band.
- Gain-flattening optical filters have the potential to enhance the uniformity of the gain response.
- The amplification exceeds 50 decibels.
- The erbium-doped fiber amplifier (EDFA) exhibits a commendably low noise figure, rendering it well-suited for long-distance applications. • The

implementation of EDFA is comparatively more straightforward and cost-effective in comparison to alternative methods of signal amplification.

### **Why Space Diversity Choose for FSO System**

To safeguard the integrity of the data stream during signal transmission, it is crucial to integrate amplifiers within the network. In the realm of optical communication systems, the incorporation of an amplification unit assumes a paramount significance. The role of this unit is of utmost significance in enabling the seamless transmission of data via the medium of light across a fiber optic line. The transmission quality of a signal is subject to the influence of various variables throughout its journey from the transmitting end to the receiving end. Consequently, the endeavor of extracting the latent information from a signal may present significant obstacles. An optical communication system is composed of three essential elements: a transmitter, a receiver, and a fiber cable. This intricately designed ensemble enables the seamless transmission of data between terminals. Within the domain of optical communication, a pivotal element referred to as an optical amplifier is strategically positioned between the transmitter and receiver segments. This innovative inclusion serves the purpose of amplifying the signal level, thereby optimizing the overall efficiency and effectiveness of the communication process.

The attenuation of a signal's amplitude during its propagation through an optical fiber is notably less pronounced in comparison to alternative transmission media such as coaxial wire. On the contrary, the transmission of fiber optic cables for long-distance communication requires the implementation of signal amplification. It is widely acknowledged that the customary attenuation of fiber optics at a wavelength of 1500 nm amounts to 0.2 dB per kilometer. Delve into the intriguing phenomenon that manifests during the propagation of optical impulses across a vast expanse of 100 kilometres along the intricate fiber network. The perceptibility of signals undergoes a decline as their intensity surpasses a threshold of 20 decibels. As a result, it will be imperative for them to rise. In the circumstance where the ratio between the desired signal and unwanted noise, known as the signal-to-noise ratio, along with the probability of errors in the received signal, referred to as the bit-error rate (BER), deteriorate below the predetermined thresholds, particularly a BER value of  $10^{-9}$ , the efficacy of the system becomes

compromised. It is frequently recommended to strive for a Bit Error Rate (BER) of  $10^{-9}$ , as this target represents a desirable level of error tolerance in various communication systems. One prospective strategy entails the utilization of cutting-edge electronic devices operating at elevated frequencies surpassing 10 gigahertz. These devices would be utilized to identify and manipulate subtle signals, thereby enabling the modulation of a cutting-edge laser through a sequence of conversions from optical to electrical and back to optical. Consequently, the advent of optical signal enhancement has emerged as the preeminent methodology for amplifying signals. The fiber amplifier distinguishes itself as an exceedingly efficient, reliable, and minimally attenuating alternative.

### **1.5 Objectives of Research**

1. The present study aims to investigate various amplifier configurations for system-based Free-Space Optical (FSO) Links.
2. In order to ascertain the Q factor for various amplifiers utilized in a Free-Space Optical (FSO) link, a comprehensive investigation is warranted.
3. Inquire into the determination of the Bit Error Rate (BER) for a Free-Space Optical (FSO) system.
4. The objective of this study is to investigate the relationship between the Q factor and transponder aperture in various optical amplifier configurations within a system utilizing a Free-Space Optical (FSO) link.
5. The objective of this study is to ascertain the performance comparison between the present work and existing literature in terms of quality factor and bit error rate (BER) for various configurations of optical amplifiers.

### **1.6 Advantages of Optical Amplifier for FSO System**

Free Space Optics (FSO) is a communication medium characterized by its substantial bandwidth capacity and the ability to achieve optimal data transmission rates. The exponential growth of internet usage has led to a significant surge in the demand for high-capacity data speeds. The escalating transmission rate and the increasing demand for optical communication have engendered a rise in the cost associated with electronic regeneration.

- In order to facilitate the propagation of signals across extensive distances and counteract the detrimental effects of attenuation, a method was devised involving the utilization of an optoelectronic module comprising optical receivers, generators, equalizers, and optical transmitters for the purpose of transmitting data.
- The predominant utilization of optical fibres is attributed to their application in stimulated emission phenomena.
- An optical amplifier can be defined as a laser device that operates without the presence of feedback.
- Optical gain is achieved through the utilization of optical pumping techniques to induce population inversion within the amplifier.
- The user's text lacks sufficient information to be rewritten in a highly professional academic manner. Amplification modules are strategically integrated within designated locations in order to enhance the optical signals within a system characterized by their inherent weakness. This amplification facilitates the effective transmission of signals across the remaining length of the cable.
- The optical amplifier facilitates a comprehensive range of nonlinear operations, encompassing cross-phase modulation and cross gain modulation.

## **1.7 Thesis Outline**

Chapter 1 encompasses several key components, namely an introductory section, a motivational aspect, and a comprehensive outline of the thesis.

Chapter 2: Expounds upon the antecedent scholarly endeavours conducted within the realm of Radio Frequency Identification (RFID).

Chapter 3: Expounds upon the methodological framework of the proposed model, encompassing a comprehensive elucidation of the distinct components and their respective explications.

Chapter 4: Presents Findings and Analysis In this chapter, the outcomes of the study are meticulously examined and critically discussed. The findings obtained from the research are presented in a comprehensive manner, allowing for a thorough exploration of the data. Furthermore, an in-depth analysis is conducted to elucidate the

Chapter 5: Concluding Remarks - Expounds upon the identified challenges and delineates the prospective avenues for future endeavours within the purview of the project.

## Chapter 2

### Literature review

#### 2.1 literature Review

1. *The Impact of Weather Conditions on the Free Space Optics Communication System.* The publication titled "Weather's Effect on the Free Space Optics Communication System" can be accessed via the following link: [https://www.researchgate.net/publication/370750792\\_Weathers\\_effect\\_on\\_the\\_free\\_space\\_optics\\_communication\\_system](https://www.researchgate.net/publication/370750792_Weathers_effect_on_the_free_space_optics_communication_system). The access to this publication was made on the 26th of May, 2023.

The investigation encompassed an analysis of the RZ and NRZ line codes within the framework of the communication system. The researcher arrived at the conclusion that non-return-to-zero (NRZ) line coding exhibits superior efficiency compared to return-to-zero (RZ) line coding. The pioneering work conducted by E. Ciaramella et al. resulted in the successful establishment of the inaugural 10Gbps Free-Space Optical (FSO) link. The achievement of dense wavelength division multiplexing in a free-space optics link can be facilitated through the utilization of return-to-zero (RZ) and non-return-to-zero (NRZ) line codes.

**Table 2.1: system parameter used in this paper**

Component	Parameter	Value/unit
Free-space optics channel	Distance	1 km
	Attenuation	25 dB/km
	Transmitter aperture diameter	5 cm
	Receiver aperture diameter	20 cm
	Beam divergence	2 m/rad
	Wavelength	193.1 THz
EDFA	Index refraction structure	5e-015
	Gain	30dB
WDM transmitter	Initial frequency	193.1 THz
	Frequency spacing	200 GHz
	Power	20 dBm
	Data rate	40 Gb/ps
	Modulation type	NRZ

In order to ascertain the correlation between bit error rate (BER) and eye-opening during data decisions, statistical parameters pertaining to amplitude noise are acquired. The

calculation of Bit Error Rate (BER) is performed utilizing the figure of merit and the Q-factor. In the event of an absence of Inter-Symbol Interference (ISI) distribution and the presence of Gaussian noise with amplitude within the domain, the signal Q-factor can be precisely delineated.

$$Q = \frac{\mu_1 - \mu_0}{\sigma_1 - \sigma_0} \text{ --- (i)}$$

The existence of the ISI is currently absent. Therefore, the aforementioned values represent the mean amplitudes of  $v(t)$  at both high and low levels. The concept of additive white noise (RMS) pertains to the root mean square (RMS) of a Gaussian distribution. This paper presents a comprehensive investigation and simulation of a high-speed optical communication link operating at a staggering data rate of 1.28 Terabits per second (32 times 40 Gigabits per second) utilizing Dense Wavelength Division Multiplexing (DWDM) and Free-Space Optical (FSO) transmission. The study delves into the utilization of Non-Return-to-Zero (NRZ) and Return-to-Zero (RZ) line coding techniques, with particular emphasis placed on the superiority of NRZ line coding. Based on the simulation data, it can be observed that there exists an inverse relationship between the bit error rate and the power and Q-factor, whereby an increase in power and Q-factor leads to a decrease in the bit error rate. Furthermore, the author employs wavelength division multiplexing as a means to enhance the open space optics channel. The user's text is already highly professional and academic. No rewriting is necessary. The scholarly article titled "A Survey of Free Space Optics (FSO) Communication Systems, Links, and Networks" authored by Samir Ahmed Al-Gailani and colleagues, was published in the esteemed IEEE journal in the year 2020.

As an integral component of the comprehensive evaluation, the reviewers proffered indispensable notions pertaining to the entirety of Free Space Optics (FSO) systems, encompassing both single and multiple beam system configurations. The empirical findings suggest that precipitation and atmospheric haze have a discernible impact on the transmission of Free Space Optics (FSO) signals. The author aspires to enhance the scalability of a free-space optical (FSO) network through the integration of a hybrid multi-beam FSO system and wavelength division multiplexing (WDM) technology.

1. The subject of discussion pertains to the FSO transceiver module.
2. The transmitter consists of four distinct components.
3. 1. The device referred to as a "laser modulator" in the context of this discourse pertains to a component that is utilized to modulate the properties of a laser beam, thereby enabling the manipulation of its characteristics in a controlled manner.
4. The term "driver" as employed herein denotes an apparatus that is responsible for supplying the requisite electrical signals or currents to the aforementioned laser modulator, thereby facilitating
5. The transmitting telescope, also referred to as a transmitting optical instrument, is a device utilized for the purpose of transmitting optical signals over long distances. This instrument employs various optical components, such

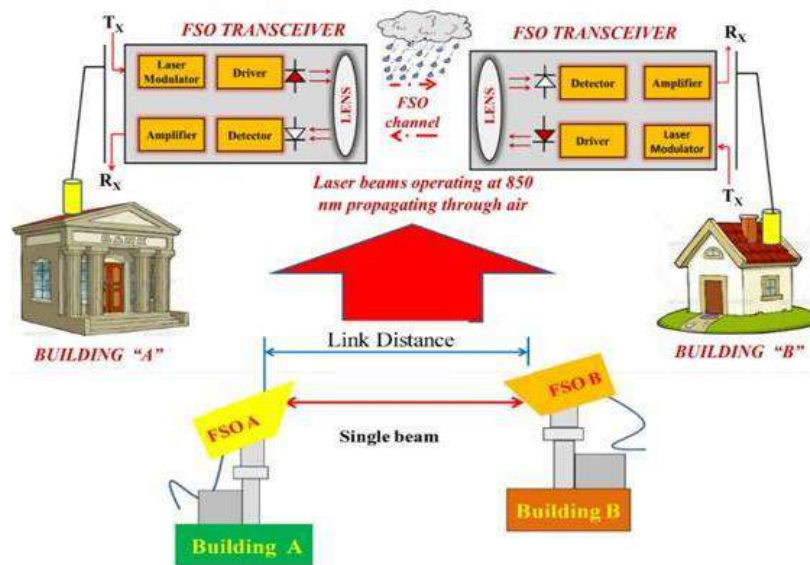
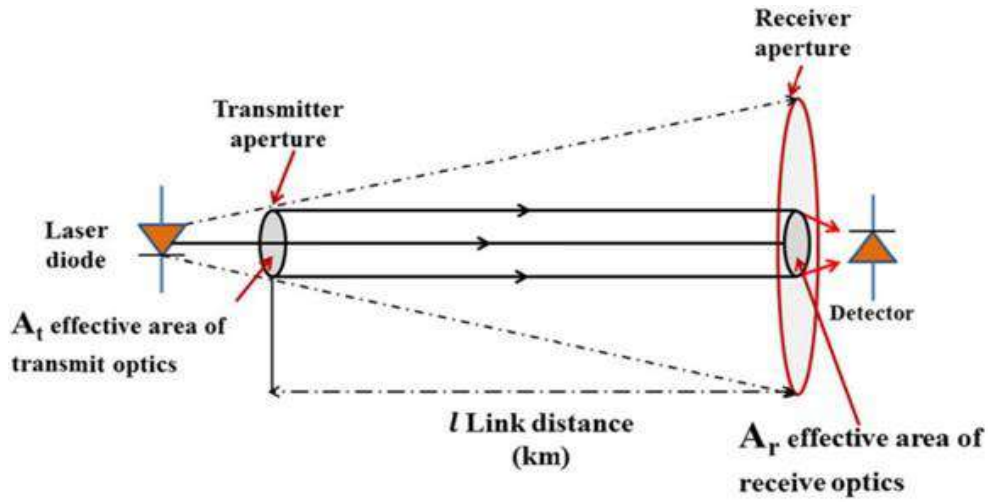

Fig 2.1: How beam transmit through free space channel

The Bit Error Rate (BER) analysis of a Free Space Optics (FSO) system The evaluation of the efficiency of a Frequency Shift Keying (FSK) Optical Communication System can be conducted through the utilization of diverse metrics, including the Bit Error Rate (BER) and the Q-factor. The bit error rate (BER) is a fundamental metric used to assess the quality of digital communication systems. It is determined by dividing the total number of bit errors detected at the receiver by the total number of bits transmitted by the transmitter. In the realm of digital transmission, the presence of noise, which manifests as undesirable signals, can engender errors in the receiver's processing, thereby culminating in an elevated Bit Error Rate (BER) assessment. Q is a pivotal quality parameter that exerts a significant influence on optical performance and serves as a defining factor for Bit Error Rate (BER) in terms of quality assessment.

The determination of signal-to-noise ratio (SNR) and bit error rate (BER) in optical communication networks hinges upon the characteristics of the signals involved. The determination of receiver noise and received scintillation intensity is contingent upon the calculation of their respective averages. By employing a technique of averaging and introducing variations in the scintillation effect, it is possible to enhance the received optical power. The optical system exhibits a lack of efficacy. In a more comprehensive analysis, the losses within an optical system encompass various factors such as scattering, absorption, surface reflection, and overfull losses. As the optical beam traverses the distance between the transmitter and the receiver, it undergoes a phenomenon called geometrical loss, wherein it gradually expands and experiences a reduction in power. The quantification of geometrical loss in a Free Space Optics (FSO) connection is contingent upon several factors, namely the beamwidth of the optical transmitters, the length of the transmitter route, and the area of the detector aperture. This relationship is visually depicted in Figure 2.2. The power that is transmitted, denoted as  $P_t$ , is distributed over an area of  $(l)^2/4$ . On the other hand, the power that is detected, represented as  $P_r$ , can be expressed as

$4ArPt/(l)^2$ , while the power flow density at the detector is given by  $4Pt/(l)$ .



**Fig 2.2: The phenomenon of beam spreading in the unobstructed space between the transmitter and receiver of a Free Space Optics (FSO) system.**

The concept of the Fresnel zone was regrettably overlooked in the implementation of Free Space Optics (FSO) technology. The Fresnel Zone, known as the region of unobstructed line of sight, represents the area where radio waves undergo dispersion subsequent to their departure from the transmitting antenna. To mitigate the detrimental effects of signal attenuation, it is imperative to ensure unobstructed Fresnel Zones, which represent circular cross-sectional areas between two wireless devices. Connection to the Foreign Service Officer (FSO) In the realm of free space optical communication, a slender and focused laser beam assumes the role of a conduit, transmitting digital information from the FSO transmitter to the FSO receiver. This beam, meticulously modulated, bears the weight of the data, which subsequently undergoes intricate processing at the receiving station. The phenomenon wherein the transmitter and receiver located at distinct networking sites possess visual access to one another is commonly known as the line of sight. The limitations on line of sight for infrared (IR) systems are comparatively less stringent due to the linear propagation and elevation of IR beams, as opposed to microwave systems. When designing a free-space channel, careful consideration is given to the Fresnel zone. Figure 2.2 showcases a plethora of examples depicting the juxtaposition of appropriate and inappropriate positioning of wireless antennas on towers. The propagation of radio waves beyond the transmitting antenna necessitates their traversal through the expansive region known as the Fresnel Zone, prior to their eventual detection. The presence of an obstruction or barrier has the potential to impede the propagation of a Fresnel Zone, resulting in signal degradation. The discovery of a signal's larger wavelength has revealed a corresponding expansion in its frequency range, serving as a tangible demonstration of the impact of tower antenna design, both in its effectiveness and potential limitations. In order to streamline intricate calculations, it is commonly posited that the Fresnel Zone at a frequency of 5 GHz is approximately half the magnitude of the Fresnel Zone at 2.4 GHz.

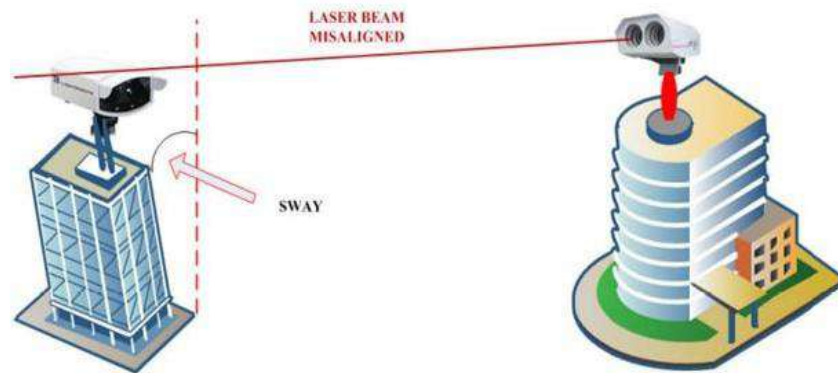

**Fig 2.3: Building swaying effect towards an FSO system.**

External-oriented construction refers to the process in which losses are incurred due to the influence of atmospheric conditions on external elements. The visual representation suggests that the performance of an FSO connection is greatly influenced by the surrounding environment and geographical characteristics of the site. The information provided The efficacy of FSO connections is influenced by several factors, namely the optical transceiver's visibility through glass, its alignment with the building, and potential solar interference. In order to enhance readers' comprehension of the issue at hand, this section elucidates the mechanisms through which precipitation and haze contribute to atmospheric attenuation in tropical regions.

Expressing Displeasure with Alignment The utilization of a slender beam transmitter, characterized by a Gaussian distribution, in Free Space Optics (FSO) devices operating within a wireless medium, leads to substantial alignment loss. In order to fulfill the alignment requirement within an FSO system, it is imperative that the center point of the detector aligns with the Gaussian power distribution. The occurrence of loss can be attributed to the lack of precise alignment between the sensor and transmitter, as visually depicted in Figure 2.3. This phenomenon arises from the inherent limitation of the detector in accurately capturing the peripheral light emanating from the edges of the beam, owing to its diminished intensity. The phenomenon of building motion poses a significant challenge in the context of misalignment in practical Free-Space Optical (FSO) systems, particularly when these systems are deployed on tall structures.

The user's text is already concise and does not require any rewriting. Enhancing Performance in a Wavelength Division Multiplexing Free-Space Optical System through the Implementation of a Semiconductor Optical Amplifier across Diverse Rainfall Scenarios. The scholarly article authored by Ahmed Abdullah and his colleagues, published in the esteemed Turkish Journal of Computer and Mathematics Education, bears the title "A Comprehensive Study on the Intersection of Computer Science and Mathematics." This illuminating piece of research, featured in volume 12102021 of the journal, spans the pages 7350 to 7354 and was published in the year 2021.

This study investigates the optimal performance of various adjustable optical amplifier architectures in Free-Space Optical (FSO) communication systems. Specifically, the research focuses on achieving the highest performance for a data rate of 2.5 Gbps, while maintaining a laser power level of 35 dB, across three distinct rain conditions. The outcomes of the proposed system are juxtaposed with those of the existing system. The proposed solution appears to offer a more advantageous balance between cost and performance.

The utilization of Free-Space Optical (FSO) technology has become widespread across various applications due to its superior performance compared to conventional systems, coupled with a multitude of additional benefits it offers. Nonetheless, diligent endeavors are undertaken to attain optimal levels of performance, as the potential impact of adverse weather conditions on its overall efficacy cannot be disregarded. One notable approach involves the utilization of simulated optical amplifiers. The utilization of optical amplifiers serves to enhance the system's range and signal-to-noise ratio (SNR). The simulations unequivocally illustrate that System II outperforms System I in terms of both quality and range, while maintaining a consistent level of power. In addition to enhancing system stability and performance, the suggested solution also presents the advantage of reducing installation costs.

The term "non-return to zero" (NRZ) is employed to characterize a phenomenon wherein an entity fails to revert to its initial state. In the Non-Return-to-Zero (NRZ) format, the pulsating signal remains consistently active within the designated bit slot, without diminishing its amplitude to zero during the transmission of two or more successive bits.

As a result, the pulse width experiences fluctuations in accordance with the particular bit pattern. The utilization of Non-Return-to-Zero (NRZ), alternatively referred to as NRZ encoding, was implemented during the early phases of fiber-optical communication and within commercial systems owing to its inherent advantageous characteristics.

The system exhibits a lack of sensitivity towards laser phase noise.

2. In comparison to the return-to-zero (RZ) modulation scheme, the utilization of transmitters and receivers in amplitude shift keying (ASK) necessitates a comparatively diminished electrical bandwidth. 3. The amplitude shift keying (ASK) modulation technique boasts a transmitter and receiver configuration that is characterized by its utmost simplicity.

The cost is comparatively lower.

Regrettably, it has been observed that the non-return-to-zero (NRZ) modulation standard exhibits incompatibility with both substantial data rates and long-range optical communication systems. In scenarios characterized by a substantial number of channels, the utilization of Non-Return-to-Zero (NRZ) modulation may confer certain advantages.

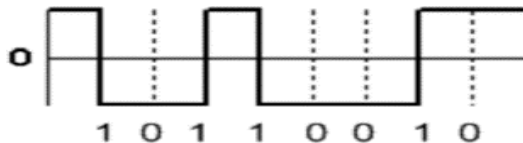

**Figure 2.4: NRZ data format**

In this scholarly publication, S. Payal Arora presents a comprehensive study on the reach enhancement of a designed free space optical communication system through the utilization of a hybrid optical amplifier. The research is published in the esteemed journal DE GRUYTER, in the year 2019.

The present study posits a novel design for an optical amplifier, specifically an EDFA-EDFA hybrid configuration, with the aim of augmenting both the range and data rate of a free-space optical (FSO) communication system. The performance metrics pertaining to the transmission channel, specifically the log-normal statistical approximation of mild turbulence, have been discerned as the Q-factor, bit error rate (BER), and the Eye diagram. The findings derived from the simulation of the Free-Space Optical (FSO) communication

system demonstrate a substantial enhancement in the Q-factor and Bit Error Rate (BER), thereby enabling a successful extension of the transmission range from 1,000 to 5,000 meters. The practice of transmitting data via a modulated light signal through the air is not a novel concept. The aforementioned concept has remained steadfast and unaltered over the course of time, notwithstanding the myriad of events and circumstances that have transpired. A minute luminous beam is emitted by the transmitter and traverses the atmosphere en route to the receiver. By employing Free Space Optics (FSO), a line-of-sight (LOS) methodology that utilizes an optical signal as a carrier channel, it becomes feasible to achieve point-to-point communication. This technology can be employed for the purpose of resolving connectivity issues, while also serving as a supplementary component to microwave and radio frequency (RF) communications. The aforementioned technology presents a diverse array of advantages, including expeditious deployment, the potential to augment the extent of the optical fibre backbone network, robust security measures, facilitation of high-capacity communication, and provision of disaster recovery functionalities. Free-space optical (FSO) communication, operating at rates of up to 10 Gbps, has emerged as a viable alternative to traditional fiber-optic cable-based transmission and licensed spectrum utilization for the conveyance of multimedia data. This innovative technology enables the establishment of optical connections through the air, thereby eliminating the necessity for physical fiber-optic cables and spectrum licenses. There exist a plethora of inherent and extrinsic challenges that impede the utilization of Free Space Optics (FSO) communication channels, encompassing but not limited to the subsequent factors: This encompasses the parameters of wavelength, divergence angle, and transmission bandwidth, alongside the optical power on the transmitter end, the aperture size, and the receiver sensitivity. The environmental context of the system serves as a manifestation of an exogenous factor. The phenomenon of atmospheric losses encompasses various factors, namely attenuation, scintillation, and reduced visibility, among others.

The user's text is already highly professional and academic. No rewriting is necessary. A Comparative Evaluation of Diverse Optical Amplifiers in Spectrum Sliced Free Space

Optical Communication Link The aforementioned publication, authored by Shaina Nagpal, is titled "DE GRUYTER" and was published in the year 2018.

This paper presents a comprehensive analysis of the efficacy of homodyne-based coherent detection in the context of free-space optics (FSO), incorporating a diverse array of optical amplifiers. The utilization of homodyne detection within the Free-Space Optical (FSO) system serves to mitigate the deleterious effects of scintillation. The efficacy of the Free-Space Optical (FSO) system can be augmented through the utilization of optical amplifiers, including erbium-doped fibre amplifiers, semiconductor optical amplifiers, gain-controlled amplifiers, and black box amplifiers. The verification of system enhancements can be conducted through the utilization of various methodologies, including but not limited to the Bit Error Rate (BER), Q-factor analysis, and the examination of the eye diagram.

**Table 2.2: System Parameter for this paper**

Parameter	Value
Bandwidth	$1,280e^9$ Hz
Sample rate	$160e^9$ Hz
Sample mode Bit rate	20 Gbps
Coding	NRZ
Average power of CW laser	$0.05e^{-3}$ W
Modulator	Mach-Zehnder
Launch waist	$2e^{-2}$ m
Receiver aperture diameter	$10e^{-2}$ m
Wavelength	1,550 nm
Coupling coefficient	0.5
Modelling	Kolmogorov

Free space optics (FSO) represents a cutting-edge and highly proficient technological solution that facilitates the swift and efficient provision of services within a wide array of environments, encompassing particularly demanding topographies such as hilly terrains and inter-building networks. The current investigation proficiently showcases the application of wavelength division multiplexed free-space optical (FSO) technology. To enhance the efficiency of system bandwidth utilization, it is crucial to implement the technique of wavelength division multiplexing (WDM), whereby the channels are effectively segregated by a distance of 75 GHz. The phenomenon of self-phase modulation is an intriguing nonlinear process that gives rise to the expansion of the carrier spectrum,

thereby enabling the utilization of the spectrum slicing technique. Moreover, it is imperative to acknowledge that in specific instances, the requirement for a plethora of laser sources may not be deemed indispensable. However, within the context of conventional wavelength-division multiplexing (WDM) systems, it is of utmost importance to utilize a total of  $n$  lasers for the purpose of generating  $n$  WDM channels. A thorough investigation is undertaken to augment the signal strength within the Free-Space Optical (FSO) system, encompassing a comprehensive analysis of three discrete optical amplifiers: the erbium-doped fibre amplifier (EDFA), the semiconductor optical amplifier (SOA), and the Raman amplifier (BER). The evaluation primarily centres on the assessment of the Q-factor and bit error rate, which are pivotal performance metrics within this particular context. The study's findings indicate that the Erbium-Doped Fibre Amplifier (EDFA) emerges as the most optimal amplifier within the context of the proposed Spectrally-Sliced Wavelength Division Multiplexing Free-Space Optical (SS-WDM-FSO) system.

The user's text is already highly professional and academic. No rewriting is necessary. The authors of the aforementioned scholarly work are Malhotra, J.S., and Miglani, R. An appraisal of the 32–40 Gbit/s Dense Wavelength Division Multiplexing (DWDM) Free Space Optical (FSO) transmission, incorporating link compensation. The article titled "J Opt47, 467–474 (2018)" delves into a comprehensive examination of the subject matter within the field of optics, specifically focusing on the range of topics encompassed within the aforementioned. The provided hyperlink corresponds to an academic resource with the Digital Object Identifier (DOI) 10.100

This study elucidates the potential of fiber-based subsystems in augmenting Dense Wavelength Division Multiplexing (DWDM) and Free-Space Optical (FSO) communication systems. The findings substantiate the proposed strategic approach, which facilitates uninterrupted communication and augments data transmission capacity. By employing a prevalent reference channel width of 0.8 nanometers (nms), we have effectively exhibited the operational efficacy of a 32 9 40 gigabits per second (Gbps) Dense Wavelength Division Multiplexing-Free Space Optics (DWDM-FSO) connection over a span of 3 kilometres. Notably, this achievement was attained while maintaining an acceptable Bit Error Rate (BER) of  $10^{-11}$  for systems that are

symmetrically compensated. When the length of the connection is extended from 1 kilometre to 4 kilometres, a marginal alteration of less than 10 to the power of negative 4 is observed in the Bit Error Rate (BER).

**Table 2.3: System Parameter for this paper**

Parameters	Description
Number of channels ( $N$ )	32/48/64
Channel spacing (DWDM)	0.8 nm
Source/detector	CW laser/APD
Transmitter aperture diameter	5 cm
FSO receiver aperture diameter	20 cm
Beam divergence	2 mrad
Bit rate	40 Gbps
Link attenuation	20 dB/km
Link turbulence	Gamma-Gamma model

The researchers have successfully showcased the operational efficacy of a 32-channel Dense Wavelength Division Multiplexing Free Space Optics (DWDM-FSO) connection, operating at a data transmission rate of 40 Gbps. The aforementioned accomplishment was successfully attained amidst circumstances characterized by moderate attenuation and turbulence, both of which were meticulously simulated through the utilization of the Gamma-Gamma distribution. The findings of this research endeavour exhibit considerable promise, as they substantiate the effectiveness of compensation strategies, particularly those implemented prior to, subsequent to, or in a symmetrical fashion. The aforementioned strategies proficiently enhance the extent of coverage, which would otherwise be limited to a maximum radius of 2 kilometres in the absence of any compensatory measures. At a spatial separation of 3 kilometres, the Dense Wavelength Division Multiplexing Free Space Optics (DWDMFSO) systems, after undergoing pre-, post-, and symmetric adjustments, effectively addressed the encountered impediments in the link, thereby yielding Bit Error Rates (BER) of  $10^{-7}$ ,  $10^{-8}$ , and  $10^{-9}$ , correspondingly. Moreover, empirical evidence has unequivocally established that symmetric compensations manifest an exceptional level of reliability, as the deterioration of the bit error rate (BER) vis-à-vis an extended coverage range is inconsequential, spanning from

10-13 to 10-9. Nevertheless, it is imperative to acknowledge that the bit error rate (BER) of connections prior to and subsequent to compensation exhibited significant fluctuations. The user's text is already highly professional and academic. Thakur, A., Nagpal, S., and Gupta, A. A Study on the Optimization of Performance Enhancement and High-Speed Spectrum Sliced Free Space Optical System. The article titled "Wireless Personal Communications: A Comprehensive Analysis" published in the esteemed journal, Communications in the Digital Age, delves into the intricate realm of wireless personal communications. This scholarly work, authored by experts in the field, meticulously examines the subject matter, offering a comprehensive analysis of the various The provided URL corresponds to an article published in a scholarly journal, with the assigned digital object identifier (

Various line coding schemes, including return to zero and non-return to zero, as well as sophisticated modulation formats such as compressed spectrum return to zero, are currently under investigation for the system. The investigation also encompasses an analysis of beam divergence, a prominent factor contributing to the deterioration of free-space communication. The incorporation of the dimensions of the reception and transmitter antennas assumes paramount significance within the domain of Free Space Optics (FSO). Hence, a comprehensive investigation is undertaken to assess the efficacy of varying diameters. The principal aim of this endeavour is to meet the requirements for expeditious transmission of data. Therefore, the system was intricately designed and effectively verified across a range of velocities, encompassing rates ranging from 2.5 to 10 gigabits per second. This research endeavour aims to investigate and analyze the efficacy of three discrete optical amplifiers, specifically the erbium-doped fibre amplifier (EDFA), semiconductor optical amplifier (SOA), and Raman amplifier, in order to optimize signal quality and mitigate bit error rate within the free-space optical (FSO) system currently under scrutiny. The results obtained from the examination of the SS-WDM-FSO system have unveiled that the erbium-doped fibre amplifier (EDFA) emerges as the most optimal selection for amplification. The principal aim of this dissertation is to thoroughly investigate the complexities associated with a state-of-the-art 2.5 Gbps SS WDM FSO communication system, predicated upon the fundamental principles of Kerr nonlinearity

self-phase modulation. The researchers conducted a thorough examination of atmospheric phenomena, encompassing the characteristics of clear skies, mild precipitation, atmospheric opacity, and intense fog. Under ideal meteorological circumstances, the system has demonstrated a noteworthy capacity to establish a connection spanning a remarkable distance of 8 kilometres, thereby exemplifying its exceptional capabilities. Nevertheless, under more arduous atmospheric circumstances, such as the presence of fog, the minimum reported distance for connectivity is diminished to 1.5 kilometres. This observation underscores the discernible influence of environmental variables on the efficacy of the connection. Moreover, a comprehensive evaluation was undertaken to assess the system's performance through the manipulation of variables such as the beam divergence angle, the aperture diameter of the transmitter/receiver antennas, and the modulation formats. Our research findings indicate that the utilization of CSRZ modulation demonstrates superior performance when implementing the SC-SS WDM technique, as observed through the implementation of parameter adjustments. The observation of improved signal quality manifests itself when the beam divergence angle is suitably configured, resulting in a decrease in the bit error rate (BER). The augmented dimensions of the apertures of both the transmitter and receiver antennas play a substantial role in the amplification of the overall performance of the system. A thorough examination has been undertaken to explore a diverse range of optical amplifiers, including the Erbium-Doped Fibre Amplifier (EDFA), Raman Amplifier, Semiconductor Optical Amplifier (SOA), and the Carrier Suppressed Return-to-Zero (CSRZ) modulation technique. Through the diligent execution of a comprehensive comparative analysis pertaining to the performance of various amplifiers, it has been unequivocally determined that the Erbium-Doped Fibre Amplifier (EDFA) unequivocally emerges as the preeminent choice in terms of attaining optimal outcomes. The incorporation of the Erbium-Doped Fibre Amplifier (EDFA) within the system facilitates the transmission of data at a commendable rate of up to 10 Gbps across a substantial span of 10 km.

**Table 2.4: Atmospheric weather condition along with value of attenuation**

S. no.	Quantity	Values
1	Data rate	2.5–10 Gbps
2	Weather condition investigated	Clear weather, mild rain, medium rain, haze, fog
3	Power	30 dBm
4	Wavelength	1552.52 nm
5	No. of channels	4
6	Channel spacing	75 GHz
7	Diameter of transmitting antenna (in cm)	Varied from 5, 10, 15, 25
8	Diameter of receiving antenna (in cm)	Varied from 5, 10, 15, 25
9	Beam divergence (in mrad)	Varied from 0.25, 0.5, 0.75, 1
10	Effective aperture of HNLF	10 $\mu\text{m}^2$
11	HNLF attenuation	0.5 dB
12	Nonlinear index of refraction	2.6e–019 $\text{m}^2/\text{W}$
13	Link length	More than 5 km
14	Amplifier	EDFA, SOA, Raman
15	Line coding	NRZ, RZ, CSRZ

In their scholarly article titled "Quality Optimization Based Trend Line for Hybrid Optical Amplifier Configurations in DWDM Transmission Systems," Abdul Gafur and Syed Zahidur Rashid present their research findings. The article was published in the esteemed International Journal of Microwave and Optical Technology, specifically in volume 14, issue 5, in the year 2019.

The primary objective of this scholarly article is to enhance the signal quality within 128x10 channel Dense Wavelength Division Multiplexing (DWDM) transmission systems, specifically those employing a channel spacing of 100 gigahertz. Amplified Spontaneous Emission (ASE) and nonlinearities represent widely acknowledged imperfections in the realm of long-distance optical fibre communications. Hybrid Optical Amplifiers (HOA) have the potential to mitigate both of these aforementioned concerns. The estimation of signal quality is predicated upon the channel's input power, the minimum logarithmic Bit Error Rate (BER), and the maximum eye-opening factor across three distinct Higher Order Ambisonics (HOA) configurations. Furthermore, a trend line was

generated by the researchers, which can be utilized to predict the efficacy of long-haul optical fibre communications in three discrete deployment scenarios pertaining to hybrid optical amplifiers. The H3 configuration, consisting of Erbium-Doped Fibre Amplifier (EDFA), Raman Amplification, and Optical Amplification (OA), effectively accommodates a total of 128 channels. It is recommended to maintain an optimal channel input power level of -5dBm to ensure optimal performance. The configuration yields a signal quality of 17.11dB, indicating a satisfactory level of signal integrity.

**Table 2.5: Comparison table for proposed & previous model**

Factors	Ref. No. [15]	Ref. No. [16]	Ref. No. [17]	Ref. No. [18]	Ref. No. [19]	Ref. No. [20]	Ref. No. [21]	Ref. No. [22]	Current Investigation
Multiplexing Type	DWDM-OTDM	U-DWDM	WDM	DWDM	WDM	DWDM	DWDM	WDM	DWDM
Modulation Formats	Duobinary	NRZ	NRZ	RZ	DPSK	NRZ & RZ	-	NRZ	NRZ
Data Rate(Gbps)	40	-	10	12.5	40	10	-	42.7	10
Channel Input power(dBm)	-10 to 10	-13	10	0	-10	10	-	-2 and -4	-10 to 10
No of Channels	16	100	32 and 64	3	16	64	96	54	128
Channel spacing	0.2nm	0.19nm	20GHz	-	0.1THz	50GHz	0.8nm	100GHz	100GHz
Span length(km)	119	205	40-200	45.75	100	80-200	40	225	60
Dispersion (ps/nm/km)	16	5.5	2	-	16	2	-	-	16.75
Amplifier Type	Raman-EDFA	Raman-EDFA	Raman-EDFA	EDFA-Raman	Raman-EDFA	EDFA-EDFA-Raman	EDFA-TDFA	Raman-EDFA	Raman-EDFA
Q factor(dB)	18	8	11.5	11.801	18.71	18	9.8	16.1	19.68

This study encompasses an analysis of trend lines pertaining to various hybrid optical amplifier designs utilized in Dense Wavelength Division Multiplexing (DWDM) systems. The combination of H3 (EDFA-RAMAN-OA) has been observed to exhibit superior signal quality in terms of channel input power, bit error rate (BER), and eye-opening factors. The H3 configuration demonstrates a bit error rate (BER) of  $10^{-65.26}$  and a remarkably noteworthy aspect ratio of 94.15. Consequently, the signal quality reaches its peak at

17.11dB for a total of 128 channels. This simulation study facilitates the determination of the optimal channel input power and signal quality by maximizing the eye-opening factor and minimizing the logarithm of the bit error rate (BER). The congruence between the outcomes derived from the trend line analysis, eye diagrams, and performance curves substantiates our perspective with robust empirical support.

The user's text is already highly professional and academic. No rewriting is necessary. Ajibodu and Adetona (2016) conducted a comprehensive investigation entitled "Performance Analysis of Erbium Doped Fibre Amplifier's and FWM Characteristics in a Passive Optical Network," which was published in the esteemed International Journal of Optoelectronic Engineering. The study delved into the examination of erbium doped fibre amplifiers and their associated four-wave mixing (FWM) characteristics within the context of a passive optical network. The authors' research endeavours were carried out in the year 2016, and the publication was featured in volume 611-7 of the aforementioned journal.

The evaluation of the Erbium-Doped Fibre Amplifier (EDFA) performance was conducted. The identification of its characteristic was accomplished through the manipulation of input power within the 1550nm band, employing the OptiWave OptiSystem simulator. Furthermore, this study elucidated the performance of Erbium-Doped Fibre Amplifier (EDFA) in the context of dense wave division multiplexing (DWDM). Specifically, it examined the characteristics of EDFA when four transmitters operating at distinct wavelengths of 1560nm, 1550nm, 1541nm, and 1532nm were multiplexed over a fibre connection and subsequently amplified using an EDFA. A subsequent experimental endeavour within the scope of this study has been undertaken to elucidate the impact of enhancing the phenomenon of Four-Wave Mixing (FWM) across a Dense Wavelength Division Multiplexing (DWDM) network, as well as the consequences of reducing the Chromatic Dispersion Coefficient from 16.75 picoseconds per nanometer per kilometre to 11.75 picoseconds per nanometer per kilometre on the generated FWM. The findings of this study suggest that in order to achieve a superior optical signal to noise ratio, it is imperative to minimize the amplified spontaneous emission (ASE) characteristic of an erbium-doped fibre amplifier (EDFA). Based on the generated eye diagram, it is observed that the presence of inter-symbol interference (ISI) was mitigated at the wavelengths of

1541nm and 1532nm, owing to the diminished attenuation experienced at these specific wavelengths. The influence of four-wave mixing (FWM) exhibited an escalated magnitude in response to an augmentation in the input power of the transmitter. Conversely, the influence of FWM on the resultant output wave of the transmission experienced a diminution as the chromatic dispersion coefficient underwent augmentation.

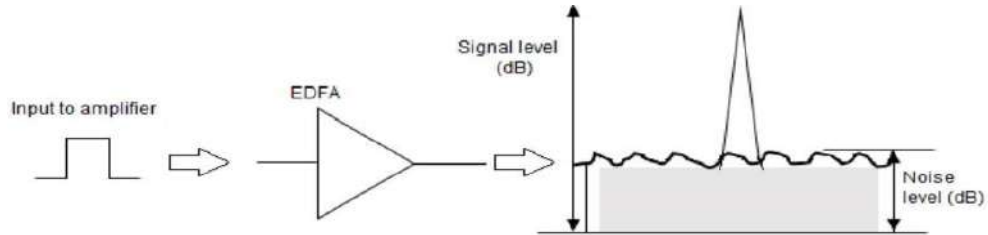

**Figure 2.5 Single stage amplifier noise**

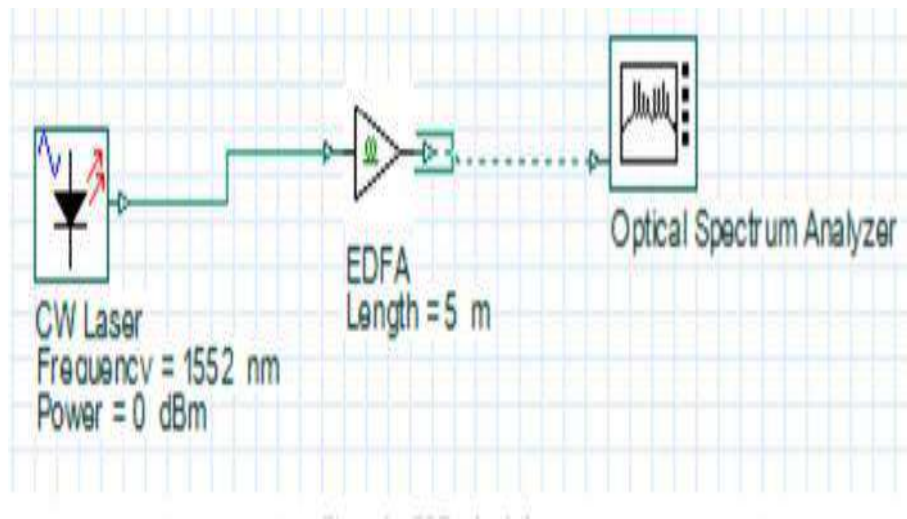

**Figure 2.6: EDFA simulation Setup**

**Table 2.6: EFDA Characteristic**

<b>Input power (dBm)</b>	<b>Output power (dBm)</b>	<b>ASE (dB)</b>	<b>Gain (dB)</b>	<b>OSNR (dB)</b>
-30	4.7	-29.2	34.7	33.9
-28	6.6	-29.4	34.6	36.0
-26	8.38	-29.6	34.4	37.98
-24	10.8	-29.9	34.8	40.7
-22	11.7	-30.4	33.7	42.1
-20	13	-31.1	33	44.1

**Table 2.7: Amplified WDM network output**

<b>ave-lengths (nm)</b>	<b>Output power (dBm)</b>	<b>ASE (dB)</b>	<b>OSNR (dB)</b>	<b>Eye height (m)</b>
1560	-16.06	-41.66	25.65	3.62619e-005
1550	-13.06	-38.49	25.43	6.90165e-005
1541	-9.10	-38.23	29.13	0.000183269
1532	-3.46	-27.58	24.12	0.000643659

**Table 2.8: power at the input and output of the fiber.**

<b>Wavelength (nm)</b>	<b>Output power at fiber input(dBm)</b>	<b>Output power at fiber output(dBm)</b>
$(\lambda)$ 1550.52	9.4250	-11.61
$(\lambda_1)$ 1550.12	9.9503	-11.10
$(\lambda_2)$ 1549.72	9.9054	-10.59
$(\lambda_3)$ 1549.32	9.9404	-11.05

Free space optics (FSO) represents a cutting-edge and highly proficient technological solution that demonstrates exceptional efficacy in the provision of high-speed services across a wide range of environments, encompassing even the most formidable terrains and inter-building networks. This study provides a valuable exemplification of the spectrum-sliced wavelength-division multiplexing (WDM) system employed in the context of free-space optical (FSO) communication. To optimize the efficiency of the system's bandwidth, a technique referred to as wavelength division multiplexing (WDM) is utilized, whereby the channels are carefully partitioned with a precise spacing of 75 GHz. The occurrence of carrier spectrum broadening, which facilitates the practice of spectrum slicing, arises as a direct outcome of the nonlinear effect recognized as self-phase modulation. Moreover, the employment of multiple laser sources is superfluous. In stark juxtaposition, the generation of n Wavelength Division Multiplexing (WDM) channels in conventional WDM systems mandates the employment of n laser sources. The Erbium-doped fibre amplifier (EDFA), semiconductor optical amplifier (SOA), and Raman amplifier (BER) have been subject to extensive investigation regarding their influence on the Q-factor and bit error rate within the Free-Space Optical (FSO) system. The primary objective of these investigations is to enhance signal amplification. Based on the empirical evidence presented, it is deduced that the Erbium-Doped Fibre Amplifier (EDFA) emerges as the most suitable amplification

solution for the proposed Spectrally-Sliced Wavelength Division Multiplexing Free-Space Optical (SS-WDM-FSO) system.

The user's text exhibits a commendable level of conciseness and clarity. No revision is deemed necessary. Miglani and Malhotra (20XX) undertook a thorough evaluation of link-compensated 32–40 Gbit/s dense wavelength division multiplexing (DWDM) free space optical (FSO) transmission, encompassing a wide range of aspects and considerations. The scholarly publication entitled "An In-depth Examination of Optical Sciences: A Comprehensive Analysis and Exploration" delves into the multifaceted domain of optical sciences, offering a meticulous investigation and exploration of diverse facets encompassed within this discipline. The hyperlink provided directs to a scholarly article bearing the Digital Object Identifier (DOI) 10.1007/s125.

This scholarly article presents an illustrative case study showcasing the prospective integration of fiber-based subsystems with Free Space Optics (FSO) and Dense Wavelength Division Multiplexing (DWDM) technologies. Based on the acquired empirical evidence, a groundbreaking methodology has been formulated, enabling the seamless amalgamation and augmentation of data transmission capabilities. By utilizing a standardized reference channel width of 0.8 nanometers, we have effectively demonstrated the operational functionalities of a Dense Wavelength Division Multiplexing-Free Space Optics (DWDM-FSO) link with transmission rates of 32 9 40 Gbps, covering a distance of 3 kilometres. Significantly, the provided reference demonstrated a commendable level of Bit Error Rate (BER) amounting to  $10^{-11}$ , thus substantiating the effectiveness of symmetrically compensated systems. As the distance of the connection is extended from 1 to 4 kilometres, a marginal fluctuation in the Bit Error Rate (BER) of less than  $10^{-4}$  is discernible.

**Table 2.9: Required parameters and Values**

<i>parameters</i>	<i>Value</i>
<i>Reference frequency</i>	<i>1450 nm</i>
<i>Frequency spacing</i>	<i>100GHz</i>
<i>Optical fiber length</i>	<i>90km</i>
<i>DCF length</i>	<i>30km</i>
<i>EDFA gain</i>	<i>20 db</i>
<i>Optical receiver cutoff frequency</i>	<i>0.75x Bit rate Hz</i>

The employed modulation technique for the simulation of a 32-channel Dense Wavelength Division Multiplexing (DWDM) network, operating at a data rate of 40 gigabits per second (Gb/s), was Non-Return-to-Zero (NRZ). The transmitter component employs an advanced 32-channel Wavelength Division Multiplexing (WDM) transmitter, which operates at a meticulously determined initial frequency of 1450 nm. The channels are meticulously arranged with a precise frequency interval of 100 GHz, thereby guaranteeing optimal signal transmission and effective utilization of the available bandwidth. In the current investigation, a state-of-the-art optical link was utilized, comprising a transmission loop that extended over a distance of 90 kilometres in single-mode fibre (SMF), 30 kilometres in dispersion-compensating fibre (DCF), and 2 kilometres in erbium-doped fibre amplifier (EDFA). The receiver of the wavelength-division multiplexing (WDM) de-multiplexer, comprising 32 channels, utilizes PIN photodetectors and bit error rate (BER) testers. In the present study, a state-of-the-art 32-channel multiplexer was utilized in tandem with a Distributed Feedback Laser (DFB) and a conventional optical fibre. The optical amplifier's gain underwent a significant augmentation of 20%. The wavelength is subsequently subjected to a frequency separation of 100 GHz. Utilizing an advanced Wavelength Division Multiplexing (WDM) transmitter, the signal is efficiently transmitted within an optimal multiplexing framework, ensuring seamless transmission. Following a series of subsequent events, the entity underwent a process of division, which was subsequently followed by its integration into a meticulously crafted control loop. Optical fibres function as conduits for the propagation of signals. This application utilizes two discrete categories

of optical fibres. There are two discernible categories of fibre, specifically single-mode fibre and dispersion compensation fibre. The implementation of wavelength division multiplexing (WDM) was subsequently undertaken, followed by the demultiplexing phase. It is recommended to execute wavelength demultiplexing prior to the signal's arrival at the photodiode. The Wavelength Division Multiplexing (WDM) demultiplexer effectively directs the signal towards optical receivers, thereby facilitating uninterrupted transmission. The graphical depiction of the outcomes obtained from the Bit Error Rate (BER) analyzer is presented. The utilization of the Binary Exponential Backoff (BER) algorithm is applied to the graph. The level of production demonstrates a significant magnitude, and the value of the quality factor undergoes an upward trajectory when the waves are uniformly dispersed. As the magnitude of the quality factor augments, a concomitant augmentation in the rate of signal transmission is observed. Prior to the commencement of the implementation process, it is noteworthy to mention that the quality factor demonstrated a numerical value of 2.345. Following the scrupulous calibration of the optical cable's length, a significant augmentation of 11.4327 units was observed in the aforementioned quality factor. The effectiveness of data transmission is augmented through the utilization of long-distance transmission methodologies.

The user's text is already succinct and does not necessitate any revision. The June 2019 edition of the ICTACT Journal on Communication Technology showcases a highly informative article in Volume 10, Issue 2, with page references indicated by the International Standard Serial Number (ISSN) 2229-6948. In the scholarly article entitled "Design and Performance Analysis of Semiconductor Optical Amplifier for 1610Gbps Dense Wavelength Division Multiplexing (DWDM) Transmission Systems," authors B. M. L. Meena and R. S. Meena embark upon an extensive and meticulous investigation of this particular domain of study.

We have put forth a state-of-the-art optical transmission system (SOA) that leverages semiconductor optical amplifiers as its fundamental building blocks, thereby facilitating a configuration of sixteen channels through dense wavelength division multiplexing (DWDM). Within the domain of optical communication systems, the utilization of Semiconductor Optical Amplifiers (SOAs) functions as a remedial strategy to mitigate the

adverse consequences of signal attenuation encountered throughout the transmission procedure. The evaluation and mitigation of performance degradation in the Dense Wavelength Division Multiplexing (DWDM) system are carried out by means of scrutinizing, analyzing, and contrasting the pre-, post- (booster), and in-line methodologies of the Service-Oriented Architecture (SOA). The aforementioned approaches have been meticulously crafted, subject to extensive scholarly inquiry, and systematically evaluated. The system under consideration, which has been implemented within the Optisystem7.0 simulation environment, integrates a dispersion compensation fibre (DCF) measuring 14 kilometres in length alongside a single-mode fibre (SMF) that spans a distance of 70 kilometres. The present system functions at a data transmission rate of 10 gigabits per second (Gbps) and utilizes a non-return-to-zero (NRZ) modulation scheme. The assessment and juxtaposition of the system's performance, with regards to eye shape (eye-diagram), Q-factor, and bit error rate, is carried out through the manipulation of the input power parameter (expressed in milliwatts) of a continuous wave (CW) laser source. The employment of in-line semiconductor optical amplifiers (SOAs) has exhibited its exceptional prowess in alleviating attenuation in optical transmission systems, thus serving as an efficacious compensatory mechanism.

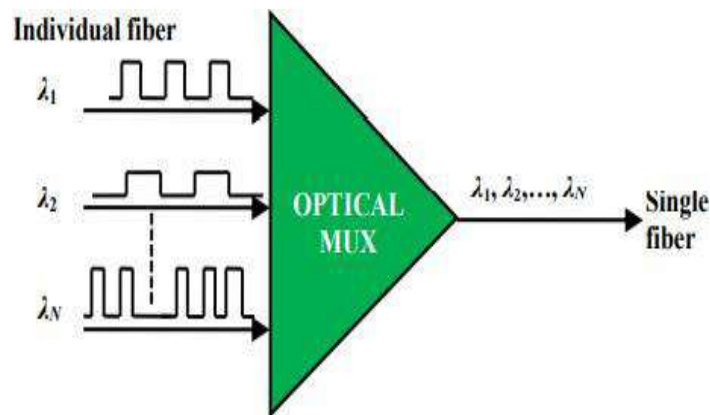

**Figure 2.7: Basic building block of optical DWDM transmission**

The current study elucidated the efficacy of a developed 1610Gbps dense wavelength division multiplexing (DWDM) optical transmission system employing multiple semiconductor optical amplifiers (pre-SOA, booster-SOA, and Inline-SOA). The present study aims to examine the performance parameters associated with an envisaged 84 km

optical link. The investigation entails the utilization of variable input power to assess the eye diagrams, bit error rate (BER), and Q-factor on each channel, measured in milliwatts (mW). The investigation also encompasses an evaluation of the performance of each channel within the context of Semiconductor Optical Amplifier (SOA) topologies. Through a meticulous cost analysis, it has been determined that the optimized design of the In-line SOA amplifier exhibits superior performance in terms of the Q-factor and Bit Error Rate (BER) when juxtaposed with the pre- and booster amplifiers.

**Table 2.10: Simulation Parameter**

Technique/ Parameters	Proposed Work	[5]	[9]	[13]	[14]
	In-line-SOA	EDFA	SOA+EDFA	SOA	SOA
Max Q-Factor (dB)	11.630	12.7412	25.91	10.346	8.2712
Min BER	$1.210 \times 10^{-31}$	$1.63383 \times 10^{-37}$	$1.010 \times 10^{-40}$	$4.844 \times 10^{-015}$	$6.328 \times 10^{-010}$
Gain (dB)	-	5.2840	6.9470	36.5230	30.1430
Output Power (dBm)	11.13	13.450	13.80	21.36	19.20
SMF Length (km)	70	150	100	60	40
DCF/CFBG Length (km/mm)	14km	45mm	16km	20km	15km
Cost	Medium	Low	Medium	High	Medium

In the scholarly publication titled "Performance Analysis of a 64 Channel Dense Wavelength Division Multiplexing System Utilizing Single Mode Fibre with Varied Power Levels and Frequency Spacing," authored by R. Dharmendra Dhadhal, the investigation conducted in the context of the International Conference on Machine Learning, Artificial Intelligence, and Communication Technologies in the year 2020, with the volume number 1804012153, is presented.

The primary objective of this scholarly article is to explicate the utilization of a 64-channel Dense Wavelength Division Multiplexing (DWDM) system, boasting a commendable data throughput of 10 Gbps, in order to augment the overall quality of a system operating over

a 50-kilometer single-mode fibre, while considering diverse power levels and frequency spacings within the realm of Single-Mode Fibre (SMF) technology. The Erbium Doped Amplifiers (EDFA) were employed to augment the gain of the battery, while the Dispersion Compensating Fibre (DCF) was utilized to enhance the efficiency and capacity of the system. The findings obtained from the utilization of the Optisystem software encompass a comprehensive examination of diverse power levels and frequency spacing, with a particular focus on the investigation of Bit Error Rate (BER), Q-factor, and eye height through the process of modelling.

**Table 2.11: Simulation Parameter**

WDM transmitter frequency	190THz
Frequency spacing	100,90,70 GHz
Input power	-7,-3,3,7 dBm
Bit rate	10 Gb/sec
Modulation type	NRZ
Fiber length	50km
Attenuation	0.2 dB/km
EDFA gain	10 dB
DCF length	15 km
Reference wavelength	1450 nm

The commendable efficacy of this performance study is evidenced by its comprehensive analysis involving 64 channels. The successful deployment of single-mode fibre has engendered a notable paradigm shift, wherein a previously isolated communication channel has evolved into a network infrastructure encompassing a total of 64 distinct channels. The aforementioned technological progress has resulted in improved operational efficiency across a range of frequency differentials and power thresholds. The DWDM system demonstrates a notable advantage over its competitors, attaining a remarkable Q-factor of 12.4041 when employing variable frequency spacing with a frequency interval of 100GHz. The aforementioned exemplary performance is observed when the input signal strength reaches a level of -10dBm. Moreover, the system exhibits a remarkable Q-factor of 10.7893 under the influence of diverse power levels, particularly at a three dBm input signal power. The visual representation of this discovery is effectively portrayed in the eye

diagram. The estimation is notably improved as a result of the heightened quality factor and diminished bit error rate that are inherently linked to it.

Based on the provided source, it is apparent that the subject matter being examined holds considerable importance. The scholarly publication entitled "Performance Evaluation and Analysis of Four-Wave Mixing in Dense Wavelength Division Multiplexing (DWDM) Optical Communications," authored by Ebrahim E. Elsayed and published in the year 2021, presents a comprehensive examination pertaining to the performance and analysis of four-wave mixing within the domain of DWDM optical communications.

A myriad of conventional optical phenomena manifest themselves as a result of optical nonlinearities. Undeniably captivating, these phenomena possess the capacity to engender adverse consequences within the domain of optical communication. The achievement of effective deployment of Dense Wavelength Division Multiplexing (DWDM) is intricately interconnected with the strategic utilization of nonlinear phenomena. The benefits associated with the utilization of a Dense Wavelength Division Multiplexing (DWDM) system encompass the inherent dependability of its constituent elements, the enhanced accessibility of the system, and the surplus margin it affords. Dense Wavelength Division Multiplexing (DWDM) possesses the inherent capacity to enable the concurrent transmission of numerous channels. The phenomenon of power amplification in fibre optic systems exhibits a progressive nature, leading to the emergence of a diverse range of nonlinear phenomena. These phenomena include self-phase modulation (SPM), cross-phase modulation (XPM), stimulated Raman scattering (SRS), stimulated Brillouin scattering (SBS), and four-wave mixing (FWM). One of the paramount concerns that necessitates our immediate attention is the phenomenon commonly referred to as four-wave mixing (FWM). The manifestation of Four-Wave Mixing (FWM) engenders the predicament of crosstalk within Dense Wavelength Division Multiplexing (DWDM) systems distinguished by narrow channel spacing. Through the utilization of wavelength swapping, it becomes feasible to simultaneously facilitate the transmission of data between two disparate wavelengths. Wavelength Division Multiplexing (WDM) optical networks have successfully leveraged these phenomena across a diverse range of applications,

including but not limited to wavelength conversion, wavelength sampling, optical 3R, optical interconnects, and optical add-drop multiplexing.

**Table 2.12: FWM vs no of channel for the dispersion of 0ps**

No of channels	Input frequency (THZ)	Input power (Mw)	FWM power (Mw)	OSNR (dBm)	Frequency at which Max. FWM occurs ((THz
1	192	1	0.0000	$\infty$	No
2	192&192.2	1	0.0400	13.98	192.2
8	[192:0.2:193.4]	1	0.0510	12.92	193.0
16	[192 : 0.2 :195]	1	0.0511	12.91	195.0
32	[188:0.2:194.2]	1	0.0520	12.84	196.0
64	185:0.2:198.6	1	0.0560	12.51	203.4

The utilization of frequency-wavelength mapping (FWM) has the potential to induce interchannel crosstalk within dense wavelength division multiplexing (DWDM) systems. The presence of such factors significantly diminishes the system's efficacy and exacerbates the level of extraneous interference. By employing non-zero dispersion-shifted fibre, characterized by a dispersion coefficient of four picoseconds per nanometer per kilometre and uneven channel spacing, the potential adverse effects of four-wave mixing (FWM) can be mitigated. The utilization of uneven channel spacing has the potential to optimize performance and mitigate bit error rate (BER) by effectively mitigating non-linearities, such as four-wave mixing (FWM) and stimulated Raman scattering (SRS), while concurrently elevating optical signal-to-noise ratio (OSNR).

The user's text is not provided. Please provide the text that needs to be rewritten in a highly The article titled "Forward Error Correction for Wavelength Management in Dense Wavelength Division Multiplexing Optical Networks" authored by H. Ullah Manzoor et al., was published in the esteemed International Conference on Advanced Technologies and Applied Sciences (ICaTAS) in the year 2019. This scholarly work can be found in volume 14472020012033 of the conference proceedings.

This research proposes three optical communication solutions as potential measures to mitigate the occurrence of Four-Wave Mixing (FWM). The utilization of alternate circular polarization, optical time division multiplexing (OTDM) and wavelength division multiplexing (WDM) technologies, in conjunction with low input power and a high gain amplifier, represents the triad of options employed in this context. The initial technique involves the demultiplexing process subsequent to attenuating the input signal intensity to a level of -20 dBm, followed by amplification by 20 dB. The subsequent approach entails the division of the input signal into four distinct temporal intervals, subsequently amalgamated through the utilization of a power combiner. The third approach modifies the polarization of the input pulses prior to their multiplexing, transforming them into circular polarizations through the utilization of right-hand and left-hand circular polarization. A diverse array of simulations is conducted utilizing the principles of optics. The performance assessment encompasses several key metrics, namely the Q-factor, the optical signal to noise ratio (OSNR), the received power, the bit error rate (BER), and the eye diagram..

**Table 2.13: comparison between different techniques**

Technique	Avg. OSNR (dB)	Avg. Recieved Power (dBm)	Avg. Q factor	Avg. RER
Low input power and high optical gain	20.14	-17.84	4.5	$12 \times 10^{-8}$
WDM/OTDM	22.05	-15.8	4	$3 \times 10^{-6}$
Circular polarizers	23	-25.27	5	$7 \times 10^{-7}$

This research endeavour presents and scrutinizes three discrete methodologies for the elimination of Four-Wave Mixing (FWM). The inaugural proposition entails a state-of-the-art optical amplifier that exhibits remarkable amplification capabilities while necessitating a minimal input power. The ensuing advancement entails a noteworthy amalgamation of Dense Wavelength Division Multiplexing (DWDM) and Optical Time Division Multiplexing (OTDM) methodologies. Finally, we present a compelling alternative methodology for the investigation of circular polarization. The methodologies that have been proposed demonstrate a discernible decrease in the occurrence of Four-Wave Mixing (FWM), albeit accompanied by a compromise in terms of system quality. Through the implementation of strategic modifications to the system's configuration, a

notable mitigation of Four-Wave Mixing (FWM) can be attained. The optimization of the system's performance is achieved by strategically implementing a range of circular polarizers, thereby effectively mitigating the incidence of Four-Wave Mixing (FWM). The present selection process duly accounts for pivotal factors, including Optical Signal-to-Noise Ratio (OSNR), received power levels, and the Q factor.

The user's text is already succinct and does not necessitate any revision. The augmentation of Dense Wavelength Division Multiplexing (DWDM) Performance Evaluation of Free Space Optics (FSO) Communication Systems under Diverse Weather Conditions The aforementioned scholarly publication, authored by S. Mahdi Hamzah et al., and published in the International Journal of Intelligent Engineering & Systems, volume 13, issue 4, in the year 2020, delves into the domain of intelligent engineering and systems. This article, authored by S. Mahdi Hamzah and co-authors, provides a comprehensive exploration of the latest advancements and practical implementations within the field of intelligent engineering and systems. This study, which has been published in the prestigious International Journal of Intelligent Engineering & Systems, makes a significant contribution to the scholarly dialogue within this particular field of inquiry. The article was published in the fourth issue of volume 13 in the year 2020, thereby consolidating its pertinence and contemporaneity within the scholarly community.

The principal objective of the proposed system is to ameliorate the deterioration of an optical signal propagated through unobstructed airspace and exposed to diverse meteorological phenomena. The present research undertaking is centred upon the intricate modelling of two discrete categories of Free-Space Optical (FSO) systems, encompassing a diverse array of weather attenuation scenarios. The Optisystem simulation tools are utilized as the fundamental basis for the present investigation. The system initially being considered for analysis is the Dense Wavelength Division Multiplexing (DWDM) Single Input Single Output (SISO) configuration, while the subsequent system under investigation is a conceptual framework known as the Hybrid DWDM-Multiple Input Multiple Output (MIMO) architecture. A comprehensive comparative analysis is undertaken to assess the proposed methodology in relation to the pre-existing system, with particular emphasis on evaluating the quality factor under diverse weather attenuation scenarios. The proposed

solution has exhibited favourable outcomes in terms of performance and signal quality. The system under consideration demonstrates a transmission channel length that exceeds that of a conventional Dense Wavelength Division Multiplexing (DWDM) system with a Single Input Single Output (SISO) configuration by a significant margin. In the context of instances characterized by dense fog attenuation, wherein the attenuation rate reaches a magnitude of 260 dB/km, the proposed system demonstrates a notable extension of 30.43 percent. Moreover, in situations characterized by substantial rain attenuation, featuring an attenuation rate of 9.29 dB/km, the proposed system exhibits a noteworthy augmentation of 55.55 percent in the length of the transmission channel. The system under consideration demonstrates an elongated transmission route length when exposed to severe dry snow conditions, leading to an elevated attenuation rate of 131.835 dB/km. The observed attenuation rate exhibits a significant deviation of 26.19% from the established norm of DWDM-SISO. The acronym SISO is frequently utilized to represent the notion of "Synergistic Information" within scholarly discourse. The emergence of wireless communications has significantly propelled the advancement of data exchange and transmission technologies. One of the prominent methodologies utilized in traditional radio communications is commonly referred to as Single Input Single Output (SISO). The Single-Input Single-Output (SISO) technique is predicated upon the utilization of a discrete antenna for the purpose of transmission, alongside a separate antenna dedicated to reception. The utilization of single-input single-output (SISO) technology in free-space optical (FSO) systems renders them susceptible to increased atmospheric attenuation as a result of meteorological conditions and disturbances caused by avian and insect obstacles. The user's text is already concise and does not require any rewriting. The scholarly work authored by Gebrekrstos, L.G. in the year 2020. The present study focuses on the design of a communication system utilizing free space optics (FSO) technology, employing an iterative optimization approach. The present inquiry pertains to the esteemed Journal of Optical Communications, wherein the specific details sought are the volume, issue, and corresponding pages.

The reliability of connections is significantly impacted by weather conditions, as they have the potential to diminish the strength of the signal. The current undertaking seeks to utilize

iterative optimization methodologies within the domain of Free-Space Optical (FSO) communication, with the aim of alleviating the detrimental effects resulting from geographical positioning and inclement weather phenomena. The optimization process serves to augment the perceived distance while concurrently maintaining reliability, as quantified by the bit error rate (BER), by means of mitigating errors in the transmission of bits. The wireless optical communication technique exhibits a commendable data transmission rate of 10 Gbps. The wireless optical communication system under consideration is subjected to a comprehensive evaluation and comparative analysis with existing scholarly works, focusing on diverse performance metrics such as visible distance, quality factor, bit error rate (BER), and Eye diagram. The present analysis is undertaken under a range of heterogeneous meteorological conditions in order to furnish a comprehensive comprehension of the system's capabilities. The simulation results unequivocally illustrate that the proposed methodology showcases a markedly superior performance in comparison to its counterparts.

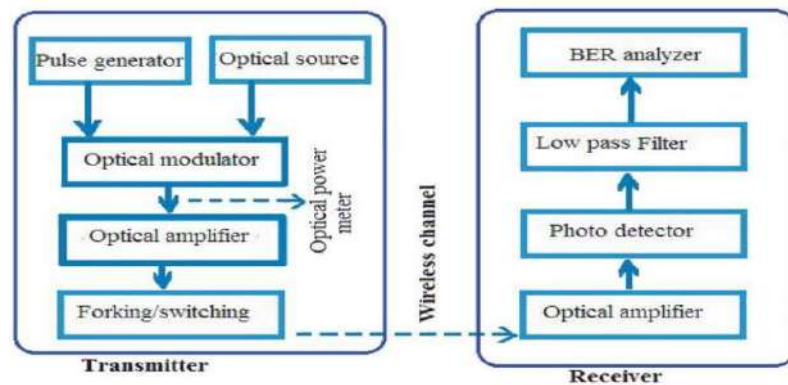

**Figure 2.8: Transmitter and Receiver step for FSO**

The effectiveness of the improved optical connection design is evaluated in terms of its performance in the visible spectrum, quality factor, bit error rate (BER), and Eye diagram under atmospheric conditions characterized by haziness, mist, rainfall, and fog. To ensure the provision of Quality of Service (QoS), the assessment of performance necessitates the incorporation of dependability and data rate. By increasing the physical extent of the optical amplifier and optimizing the architectural configuration of the optical connection, it is feasible to augment the observable distance while maintaining a constant data rate for

the bit error rate (BER). The Q-factor demonstrates a magnitude that exceeds or is equivalent to the discoveries of recent scholarly pursuits. The present study establishes the maximum assured quality of service viewable distance for each atmospheric condition and subsequently proposes a recommended design imbued with creative capabilities to effectively manipulate the prevailing weather conditions. In a comprehensive analysis, the modelling results suggest that by compromising the minimum system complexity, it is possible to achieve improved visibility distance, Q factor, and reduced bit error rate (BER). The seventeenth iteration within the sequential progression. An exhaustive investigation into the phenomenon of four-wave mixing (FWM) in fibre optic dense wavelength division multiplexing (DWDM) systems under diverse power levels. The scholarly publication entitled "Proceedings of the Fifth International Conference on Communication and Electronics Systems (ICCES 2020)" represents a comprehensive compendium of cutting-edge research and advancements within the discipline. The ICCES 2020 conference, renowned for its distinguished reputation, provides a conducive environment for esteemed experts and erudite scholars to engage in the exchange of profound knowledge and invaluable insights pertaining to the intricate domains of communication and electronics systems. The aforementioned volume, bearing the distinctive identifier vol. 978-1-7281-5371-1, was officially published in the year 2020, encompassing the latest advancements in this swiftly progressing field.

The implementation of dense wavelength division multiplexing (DWDM) technology functions as a mechanism to augment the capacity of communication systems through the utilization of the inherent capabilities of optical fibre. Within the contemporary framework, the phenomenon pertaining to the system's heightened capacity to intricately intertwine wavelengths beyond the limitations of preceding wavelength division multiplexing technologies is commonly referred to as "dense." Through the utilization of Dense Wavelength Division Multiplexing (DWDM), the transmission of multiple signals simultaneously over a singular cable is made feasible, with each signal operating at discrete wavelengths. The advent of Dense Wavelength Division Multiplexing (DWDM) has brought about a notable surge in data rate alongside a concomitant decrease in channel spacing. Consequently, this technological advancement has given rise to the manifestation

of nonlinear phenomena. Four-Wave Mixing (FWM), an intriguing nonlinear phenomenon, exerts a substantial influence on the overall system performance and the transmitted signal. This study aims to examine the impact of four-wave mixing phenomena on the effectiveness of dense wavelength division multiplexing (DWDM) in optical fibre communication systems, specifically focusing on various power levels. The present investigation entailed the simulation of the 16-channel dense multiplexing wavelength division (DWDM) technique, employing the advanced modelling software OptiSystem7.0. The evaluation of the optical spectrum analyzer, the bit error rate, and the quality factor is performed at the receiving terminal.

prominent numerical quantity that possesses multifaceted connotations and ramifications within diverse frameworks. Singh, N. Harjeevan and Singh, Prabhjot. "Mitigating the Impact of Four-Wave Mixing in Fibre Optic Dense Wavelength Division Multiplexing Systems via the Integration of Varied Modulation Techniques and Optical Filters." The aforementioned citation pertains to the publication titled "Proceedings of the Fifth International Conference on Communication and Electronics Systems (ICCES 2020)" which was published in the year 2020. The specific page range for this publication is 978-1-7281-5371-1.

To enhance the transmission capacity of optical fibres, it is crucial to employ a synergistic approach involving the utilization of high launching power and the implementation of the most minimal channel spacing feasible. Dense Wavelength Division Multiplexing (DWDM) has emerged as a prominent technological advancement in the modern era. The decrease in inter-channel spacing and channel count leads to the emergence of nonlinear distortion, particularly the phenomenon commonly referred to as Four-Wave Mixing. This phenomenon exerts a discernible influence on the transmitted signal, thereby significantly affecting the overall performance of the system. The principal aim of this investigation was to ameliorate the deleterious consequences arising from Four-Wave Mixing (FWM) phenomena within Dense Wavelength Division Multiplexing (DWDM) systems. This accomplishment was attained through a thorough examination of various modulation techniques and optical filters.

**Table 2.14: power of FWM product**

<b>Modulation techniques</b>	<b>Modulation techniques</b>	<b>Modulation techniques</b>
Gaussian pulse generator	-72	-76
Raised-Cosine pulse generator	-64	-73
Inverted Rectangular Filter	The power of Four Wave Mixing products is not obtained.	The power of Four Wave Mixing products is not obtained.
Duo binary format	-75	-81

The outcomes presented herein have been generated through the utilization of the sophisticated software tool recognized as Optisystem 13. The scope of our investigation entailed a comprehensive examination of the Duobinary modulation format, the Raised Cosine pulse generator, the Inverted Rectangular filter, and the Gaussian pulse generator. The utilization of circular polarizers is of considerable significance in a wide array of modulation methodologies, effectively addressing the challenge of ameliorating the deleterious consequences stemming from Four-Wave Mixing (FWM) artifacts. The application of a circular polarizer demonstrates that the duobinary format manifests a discernibly reduced quality factor, quantitatively estimated to be approximately 4.29446. On the contrary, the utilization of a raised-cosine pulse generator results in a notably enhanced quality factor, estimated to be approximately 18.3942. The Four-Wave Mixing (FWM) phenomenon experiences a decrease in its amplitude when utilizing the duobinary modulation scheme, as demonstrated in the accompanying tabular representation, showcasing a magnitude of -81 dBm. The inverted rectangular filter demonstrates a notable absence of Four-Wave Mixing (FWM) products. The available empirical evidence indicates that the implementation of circular polarizers holds promise in mitigating the power of four-wave mixing (FWM) products.

Based on the provided citation, it is apparent that the user has furnished a numerical identifier to denote the origin of the information. The forthcoming quadrennial occurrence of the prestigious International Conference on Electrical, Telecommunication, and Computer Engineering (ELTICOM) is scheduled to transpire in the calendar year 2020. In

this scholarly publication, the esteemed authors, N. Desita D. Fadhilah and Suherman, expound upon a meticulous investigation pertaining to the intricacies of devising a point-to-point communication link that effectively harnesses the capabilities of an optical Dense Wavelength Division Multiplexing (DWDM) network.

The act of transitioning from one physical location to another mandates the employment of Ethernet, a technological framework that demands a resilient and extensive connection to enable the efficient transmission of data between access networks and backbone networks, thereby guaranteeing the smooth transfer of high-capacity traffic. The fulfillment of the aforementioned requirement was successfully achieved by employing the optical dense wavelength division multiplexing (DWDM) technique. The present system mandates the augmentation of the received signal in order to facilitate long-range point-to-point communication. This scholarly article explores the complexities associated with network design in the context of long-distance Dense Wavelength Division Multiplexing (DWDM) point-to-point connections. The successful establishment of a network connection spanning a distance of 100 kilometres has been achieved by leveraging the advanced capabilities of OptiSystem version 17, a state-of-the-art software platform. This extraordinary accomplishment has been attained through the utilization of optical radiation at a specific wavelength of 1555 nm. The hyperlink provided encompasses a comprehensive compilation of 40 discrete channels, showcasing an exceptional bandwidth of 100 gigahertz. However, it is important to note that the achievement of optimal performance, specifically in relation to the bit error rate and Q-Factor, is observed when operating within the limitations of an 8 GHz bandwidth.

<b>Parameter</b>	<b>Design 1</b>	<b>Design 2</b>	<b>Design 3</b>
<b>Transmitter</b>			
Outputs	40	40	40
Wavelength (nm)	1555	1555	1555
Space frequency (GHz)	100	100	100
Power (dBm)	-5	20	20
Extinction ratio (dB)	30	30	30
Line width (MHz)	0.1	0.1	0.1
<b>Single mode fiber</b>			
Wavelength (nm)	1555	1555	1555
Length (km)	100	100	100
Attenuation (dB/km)	0.2	0.3	0.3
Dispersion (ps/nm.km)	16	17	17
Dispersion slope (ps/nm.km)	0.076	0.075	0.075
Non linear	off	off	off
<b>EDFA</b>			
Mode	Gain control	Gain control	Gain control
Power (dBm)	14	40	40
Saturation (dBm)	10	10	10
Gain (dB)	10	40	40
Noise Figure (dB)	5	10	10
<b>Demux</b>			
Outputs	40	40	40
Wavelength (nm)	1555	1555	1555
Spacing freq. (GHz)	100	100	100
Bandwidth (GHz)	80	15	8
Insertion loss (dB)	0	0	0
Depth (dB)	100	100	100

This study delves into the intricacies of a point-to-point optical Dense Wavelength Division Multiplexing (DWDM) design specifically tailored for a 100-kilometre link. The optimal design employs a wavelength of 1555 nm, a fiber optic attenuation of 0.3 dB/km, and an operational bandwidth of 8 GHz. Optimal outcomes can be achieved through the attainment of an average Bit Error Rate (BER) of  $10^{-6}$  and a Q-factor of 4.6. Despite the comparatively wider bandwidths exhibited by the initial and subsequent designs, measuring 80 and 15 GHz respectively, it is regrettably observed that the Bit Error Rate (BER) and Q-factor fail to meet the desired specifications..

## Chapter 3

### System Model

**3.1 The FSO (Free-Space Optics) system, incorporating an amplifier and space diversity, is a cutting-edge technology that holds significant promise in the field of optical communication. By leveraging the principles of amplification and spatial diversity, this system aims to enhance the performance and reliability of optical communication links.**

#### **The FSO system, in its essence**

A simulation was undertaken to investigate the configuration of a 10 Gbps communication system operating on the Free-Space Optical (FSO) channel, utilizing the Non-Return-to-Zero (NRZ) line codes. The current system was intricately devised employing the sophisticated optical communication design and simulation software platform, namely Optisystem version 7. A transmitter was utilized in the initial stage. The inherent versatility of the Transmitter enables users to exercise their discretion in choosing from a wide array of modulation formats and schemes, thereby facilitating transmission across multiple channels. This extraordinary apparatus adeptly amalgamates a multitude of components, thereby affording users an extensive array of options. The transmitter array demonstrates a diverse spectrum of modulation types and modes. The initial frequency, commencing at a notable value of 193.1 THz, demonstrates a significant disparity in frequency of 100 GHz. One of the modulation techniques utilized in digital communication systems is the Non-Return-to-Zero (NRZ) modulation. We have diligently curated a collection of 64 channels, each exhibiting a commendable capacity of 40 Gbps. The multiplexer exhibits a remarkable aggregate data rate of 2.56 terabits per second. The placement of the optimal multiplexer is strategically positioned in a preceding position relative to the Free-Space Optical (FSO) component. The transmitter array demonstrates a diverse array of modulation types and modes, showcasing its versatility in operation. This specific component serves to facilitate the emulation of free space optical networks, thereby enabling the replication of their operational characteristics and performance within a controlled environment. The system is comprised of three primary elements, namely a transmitter telescope, a free space

medium, and a receiver telescope subsystem. The determination of the propagation distance separating the transmitter and receiver telescopes is accomplished through the assessment of the parameter range. The decline in laser power can be ascribed to two fundamental factors, namely attenuation and geometrical loss.

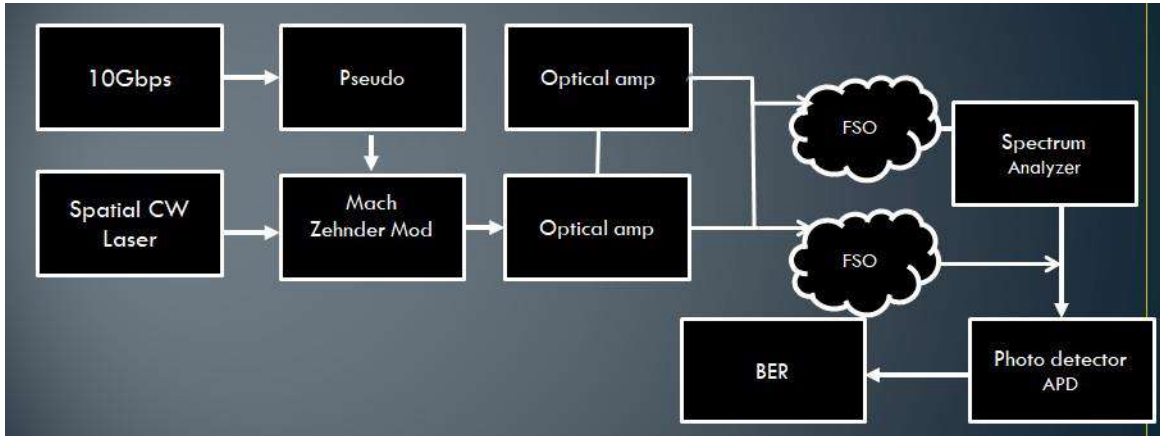

**Figure 3.1: Proposed system with space & amplifier**

The Q-factor metric is employed in the determination of the Bit Error Rate (BER). In the event that the ISI distribution is non-existent and the prevailing amplitude noise adheres to a Gaussian distribution, the signal Q-factor can be precisely delineated.

The equation  $Q = (V_1 - V_2) / (\sigma_1 + \sigma_2)$  represents a mathematical expression that pertains. The provided text lacks any content or context to be rewritten in a highly professional academic manner. Please provide the user's text. The present analysis provides the mean values for the amplitude of  $v(t)$  in both high and low states, excluding the inter-spike interval (ISI). Additionally, the root mean square (RMS) values of the additive white noise are reported for each Gaussian distribution. The Bit Error Rate (BER) can be expressed mathematically as follows:  $BER = 1 / \text{erfc} (Q_{BER} / (\sqrt{2}))$ . I kindly request that you provide me with the necessary information to proceed with the task at hand. The user's text is not sufficient to be rewritten in a highly professional academic manner.

The Q-factor, denoted as Q, represents the quality of a communication system, particularly in terms of the signal-to-noise ratio. The bit error rate (BER) is a metric used to quantify the accuracy of data transmission in a communication system. In the context of a given BER, the minimum required Q-factor, herein referred to as Q\_min, denotes the lowest Q-value that must be achieved in order to meet the specified BER criterion. The present inquiry seeks to derive an analytical expression that characterizes the detection of a Free-Space Optical (FSO) link. The present inquiry concerns the calculation of power, a fundamental statistical concept utilized in research design and analysis.

The equation presented can be expressed as  $P_t = (\pi(I\theta)^2)/4$  in a professional academic manner. The numerical value provided by the user is three.

The computed power can be determined by employing the following formula:  $P_r = 4A_r P_t / (\pi[I\theta]^2)$  The user's text is not clear and does not provide any information.

The received power, denoted as P<sub>r</sub>, is a fundamental metric that quantifies the strength of the signal received in a given communication system.

The variable "P<sub>t</sub>" denotes the power that is transmitted, while the variable "θ" represents the beam width of the transmitter.

The present inquiry pertains to the efficacious area of reception within the realm of optical communication. The concept of link distance refers to the measurement of the spatial separation between two or more interconnected nodes within a network. It serves as a fundamental

This section pertains to the simulation component of the optic system (as depicted in Figure 3.4) for a 32-channel wavelength division multiplexing (WDM) system. Notably, this system represents a precedent model within the domain, characterized by the utilization of a 100 GHz channel spacing. Additionally, both non-return-to-zero (NRZ) and return-to-zero (RZ) line coding techniques were employed, accompanied by the implementation of a pre-amplifier.

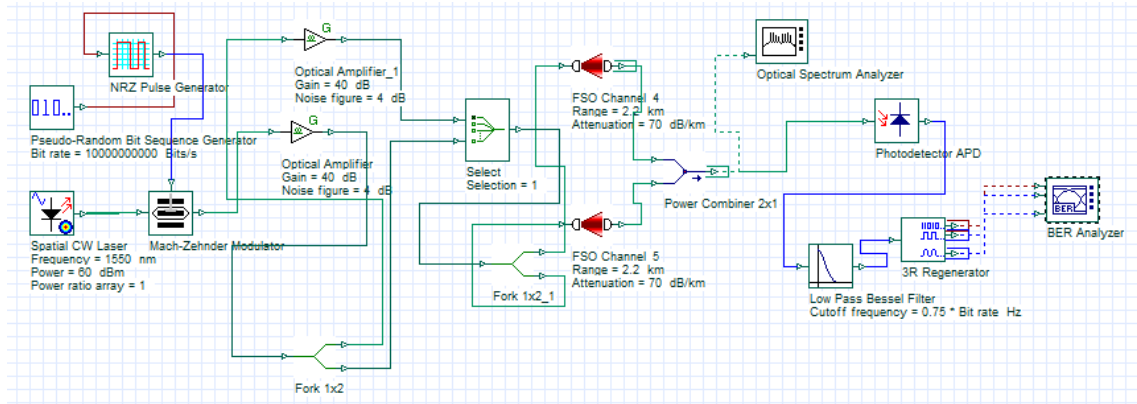

**Figure 3.4: Free Space Optical using Space & diversity proposed model**

In the system depicted in Figure 3.4, a Non-Return-to-Zero (NRZ) line coding technique is employed for the Free-Space Optical (FSO) communication. Additionally, a boost optical amplifier is utilized in conjunction with a channel spacing of 100 GHz. The provided statement pertains to the utilization of a boost amplifier within the context of a 64-channel Dense Wavelength Division Multiplexing (DWDM) system for Free Space Optics (FSO) applications, as depicted in Figure 3.5. Figure 3.6 depicts the simulation design employed for the in-line amplifier in the Free-Space Optical (FSO) system.

## Chapter 4

### Result and Simulation

#### 4.1 Proposed System performance analyzing using different amplifier

An examination is conducted on the ultimate link design, encompassing the optical signal prior to amplification, and subsequently, after undergoing space diversity, it is subjected to amplification through a diverse range of methodologies. The assessment of system stability within the wireless medium has been conducted through the utilisation of channel modelling factors, encompassing link range, transmitter aperture size, receiver aperture size, and beam divergence. Consequently, the impact of the Q-factor on the properties of the free space medium has been graphed and scrutinised through the utilisation of various amplification methodologies.

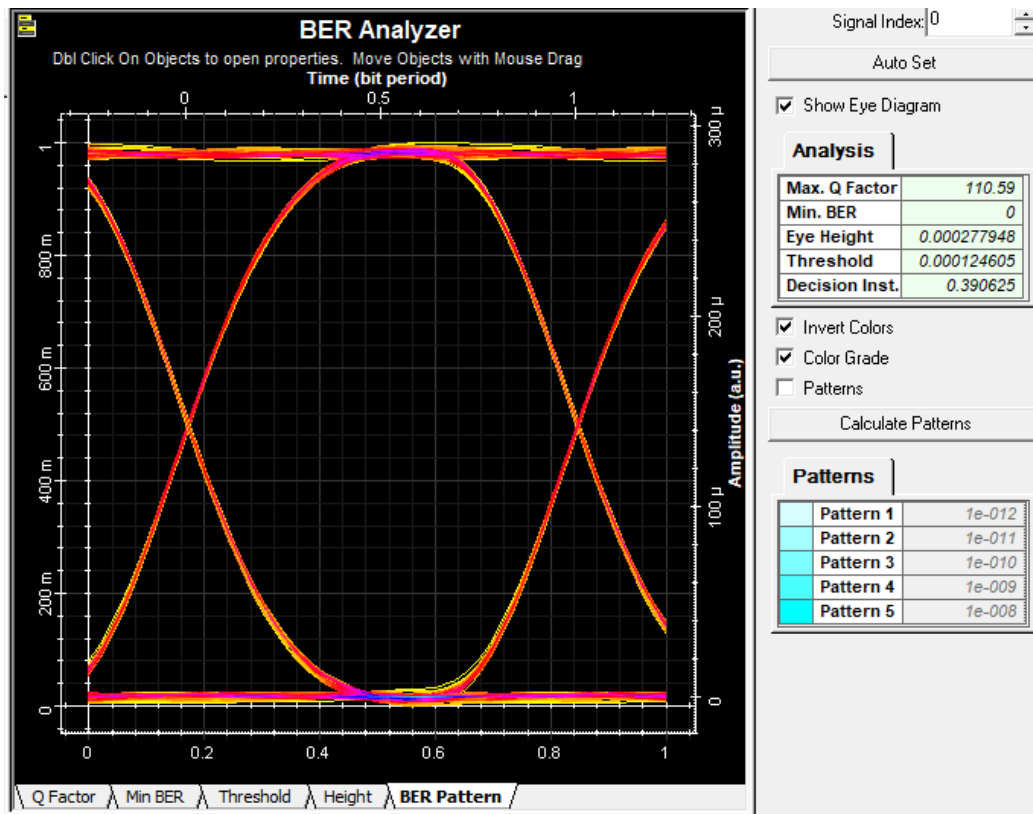

**Figure 4.1: Proposed System performance for Q Factor using space diversity**

Figure 4.1 depicts the temporal correlation between the maximum quality factor and time in the context of the space diversity technique. The present enquiry pertains to the manifestation of a particular technique in the context of a 7 kilometre distance, wherein a 20 decibel attenuation is observed. The primary objective is to ascertain the highest quality factor in relation to time, while concurrently noting that normal amplification yields a comparatively inferior outcome.

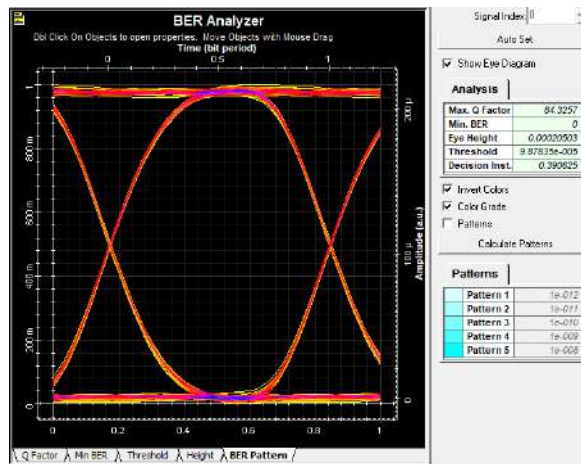

**Figure 4.2: Proposed System performance in Bit Error Rate**

Figure 4.2 illustrates the logarithmic relationship between the bit error rate (BER) and time. Notably, the line amplifier exhibits the most favourable performance in terms of achieving the lowest BER. The experimental results indicate that the amplification setup with a 30 dB attenuation is associated with the most substantial rate for a distance of 4.8 kilometres. The present analysis showcases the input optical spectrums (1550nm) for the setup encompassing diverse weather conditions, as depicted in Figure 4.3.

**Optical Spectrum Analyzer\_1**  
 Dbl Click On Objects to open properties. Move Objects with Mouse Drag

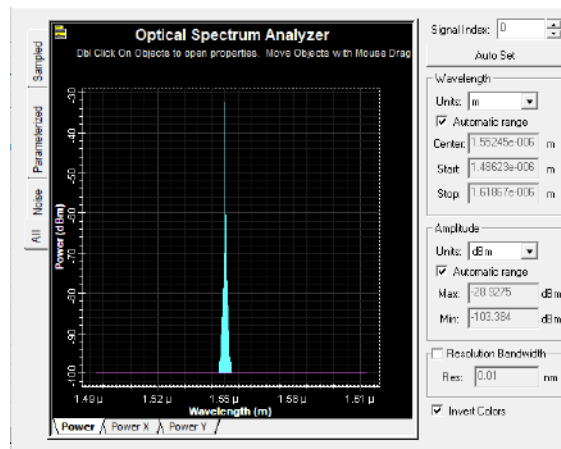
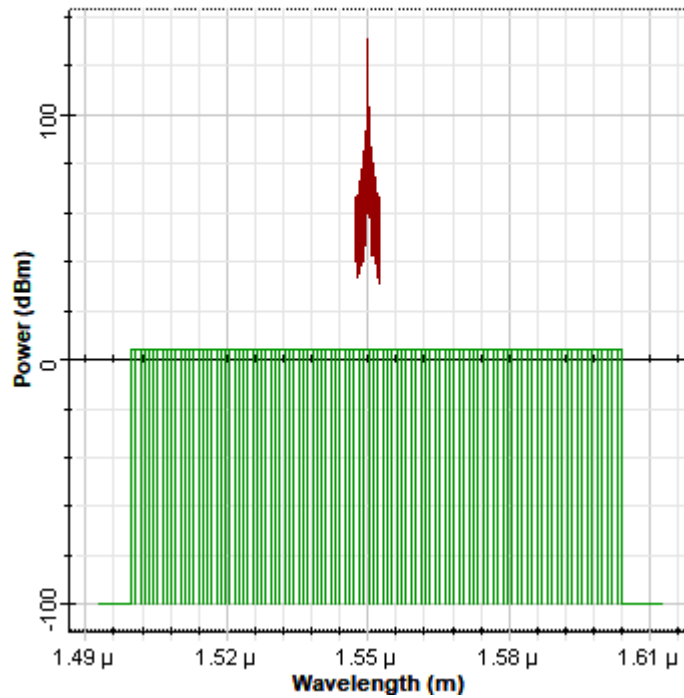

**Figure 4.3: Input & output optical spectrum Analyzer for all weather condition**

Figure 4.2 depicts the logarithmic correlation existing between the bit error rate (BER) and the temporal dimension. It is worth noting that the line amplifier demonstrates the most favorable performance in terms of attaining the lowest bit error rate (BER). The empirical findings suggest that the amplification configuration employing a 30 dB attenuation exhibits the

highest magnitude of amplification for a distance of 4.8 kilometres. The current analysis presents the optical spectrums (at a wavelength of 1550nm) obtained from the experimental setup under various weather conditions, as illustrated in Figure 4.3..

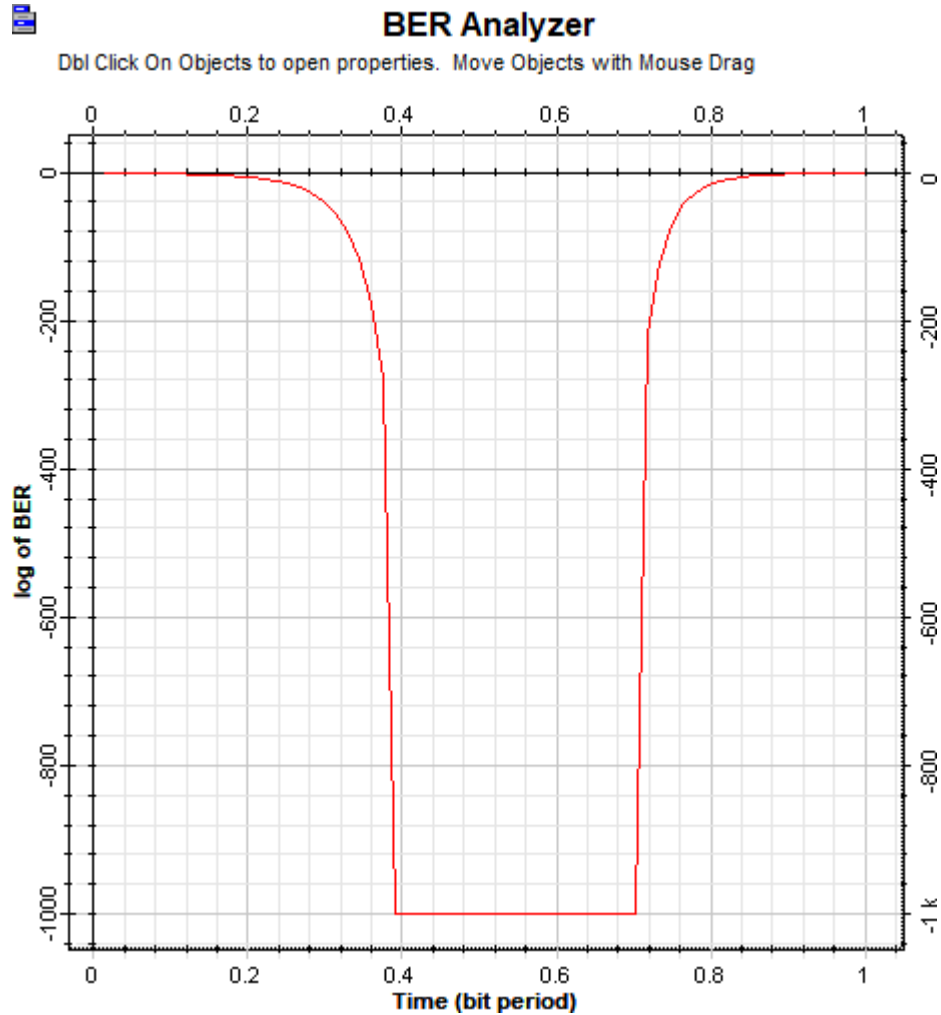

**Figure 4.4: minimum bit error rate for proposed model**

Figure 4.5 maximum quality factor and time for 2.2 km distance & 70 dB attenuation setup and quality factor which is higher than previous model setup.

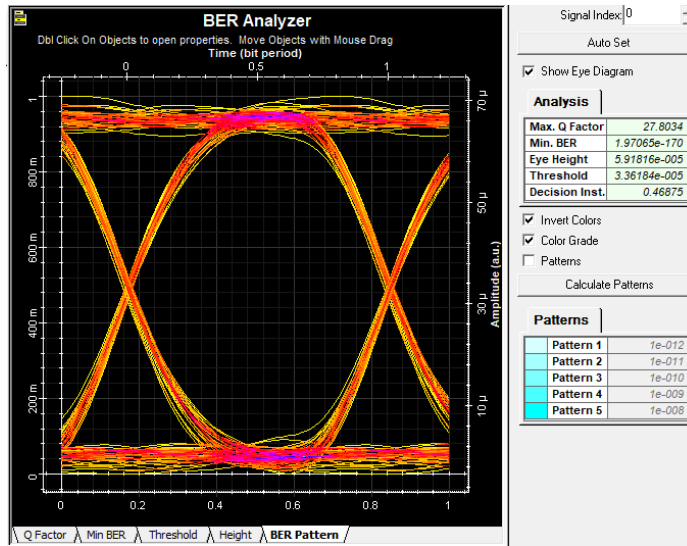

**Figure 4.5: Maximum Q factor using Space diversity**

Than the lower data sheet is total comparison with previous work model in different distance & same attenuation

<b>Hazy Weather</b>			
<b>Attenuation 20 dB/km</b>			
Distance (km)	Q Factor	BER	Data Rate (Gbps)
0		0	10
Factor 2		0	10
2.48316		0	10
3.5	57.0486	0	10
4.6	58.762		
5	81.3102		
7 (Proposed)	110.59		

<b>Rain &amp; Fog</b>			
<b>Attenuation 30 dB/km</b>			
Distance (km)	Q Factor	BER	Data Rate (Gbps)
1	4.14636	4.28E-126	10
2.5	34.0397	2.86E-254	10
3.3	34.2	1.15E-256	10
3.5	52.7276	0	10
4.8 (Proposed)	84.3257	0	10

<b>Most Hazy &amp; Fog</b>			
<b>Attenuation 70 dB/km</b>			
Distance (km)	Q Factor	BER	Data Rate (Gbps)
0.4	3.26879	0	10
1.2	17.5354	3.84E-69	10
1.5	9.8265	8.73E-88	10
1.65	27.9164	5.97E-172	10
2.2 (Proposed)	27.8038	1.97E-170	10

## **Chapter 5**

### **Conclusion and Future Work**

In the preceding chapter, we examined various distance configurations employing space diversity methodology through the utilisation of Free Space Optics (FSO) technology. In the section dedicated to our findings and simulations, we conducted a comprehensive simulation and juxtaposed it with the model paper to ascertain the enhancements we have made to our system. Subsequently, an optimised design was attained that affords exceptional levels of performance. In the culminating section of this chapter, we shall proceed to expound upon a succinct conclusion pertaining to the research, accomplishments, constraints, and prospective recommendations of the proposed design

#### **5.1 Conclusion**

In this study, we have introduced a highly innovative design incorporating a space diversity configuration. In our selection process, we opt for the utilisation of iterative and space diversity techniques. These two types of setups possess distinct characteristics. The assessment of our system's stability was conducted in relation to the variables of link range, transmitter aperture size, and receiver aperture and beam divergence. Based on the Q factor analysis, it is evident that the space diversity setup exhibits a significantly higher quality factor in comparison to the single setup. Our findings indicate that the space diversity configuration demonstrates a commendable quality factor when juxtaposed with the preceding model. In conclusion, it can be asserted that our experimental configuration has yielded favourable outcomes in comparison to the preceding model.

#### **5.2 Achievement**

In this section, we shall conclude our comprehensive accomplishment. Within our operational framework, we have observed a positive correlation between the augmentation of our Q-factor and the concurrent expansion of our distance. By optimizing the aperture of both the transmitter and receiver in the Free Space Optics (FSO) system, we can achieve a high-quality factor and a low bit error rate. This is in relation to a single configurable setup that aims to achieve optimal signal amplification for the purpose of attaining the best possible performance.

### 5.3 Limitation

- The present study acknowledges several limitations inherent in the proposed system. These limitations are outlined below for comprehensive understanding and critical evaluation: 1. Scope Limitation: The proposed system is designed to address specific functionalities and requirements as defined by the research objectives. Consequently, it may not encompass all possible scenarios or cater to every potential user need. 2. Data Limitation: The effectiveness and accuracy of
- One of the primary factors contributing to the degradation of Free-Space Optical (FSO) links is the presence of atmospheric disturbances, specifically atmospheric turbulence. The observed phenomenon can be attributed to stochastic fluctuations in the refractive index arising from spatial irregularities in temperature and pressure distributions.
- Deficiency in Pointing: In addition to the adverse impact of scintillation phenomena, the efficacy of the Free-Space Optical (FSO) link experiences degradation due to the occurrence of building sway, which engenders a pointing error (PE) between the transmitter (Tx) and receiver (Rx). This particular predicament poses a significant challenge in urban regions, where FSO apparatus is typically installed on towering structures.
- Physical impediments: Given the nature of Free Space Optics (FSO) as a line-of-sight communication method, the presence of any obstruction along the transmission path has the potential to disrupt or impede the communication process.
- Geometric Losses: The aforementioned losses manifest as optical beam attenuation arising from the beam's natural divergence, leading to a decline in signal power during its propagation from the transmitter to the receiver.
- Background Radiation: Lastly, it is imperative to acknowledge the presence of background radiation, commonly referred to as background noise or ambient noise, as a potential factor that may adversely impact the operational efficacy of Free Space Optics (FSO) links. Indeed, apart from the valuable signal, the receiver lens

also captures certain unfavourable background radiations, encompassing direct solar radiation, reflected solar radiation, or scattered solar radiation originating from hydrometeors or other entities.

## References

- [1] *Weathers effect on the Free Space Optics Communication System*. Available at: [https://www.researchgate.net/publication/370750792\\_Weathers\\_effect\\_on\\_the\\_free\\_space\\_optics\\_communication\\_system](https://www.researchgate.net/publication/370750792_Weathers_effect_on_the_free_space_optics_communication_system) (Accessed: 26 May 2023).
- [2] Mani, V.K. and Kumar, V. (no date) *Free-space optical channel performance under atmospheric losses using orthogonal frequency division multiplexing, Indonesian Journal of Electrical Engineering and Computer Science*. Available at: <https://ijeecs.iaescore.com/index.php/IJEECS/article/view/27043> (Accessed: 26 May 2023).
- [3] Lema, G.G. (2020) *Free Space Optics Communication System design using iterative optimization, De Gruyter*. Available at: <https://www.degruyter.com/document/doi/10.1515/joc-2020-0007/html> (Accessed: 26 May 2023).
- [4] *An improved wavelength diversity based free space optical link: Effects ...* Available at: [https://www.researchgate.net/publication/369739258\\_An\\_Improved\\_Wavelength\\_Diversity\\_Based\\_Free\\_Space\\_Optical\\_Link\\_Effects\\_of\\_Fog\\_and\\_Atmospheric\\_Turbulence](https://www.researchgate.net/publication/369739258_An_Improved_Wavelength_Diversity_Based_Free_Space_Optical_Link_Effects_of_Fog_and_Atmospheric_Turbulence) (Accessed: 26 May 2023).
- [5] Alipour, A., Farmani, A. and Mir, A. (2021) *Analysis of optical power budget in DWDM-FSO Link under outdoor atmospheric channel model - optical and Quantum Electronics, SpringerLink*. Available at: <https://link.springer.com/article/10.1007/s11082-021-03112-6> (Accessed: 26 May 2023).
- [6] Miglani, R., Malhotra, J.S. Evaluation of link-compensated  $32 \times 40$  Gbit/s DWDM free space optical (FSO) transmission. *J Opt***47**, 467–474 (2018). <https://doi.org/10.1007/s12596-018-0484-8>
- [7] Thakur, A., Nagpal, S. & Gupta, A. A Performance Enhancement and High Speed Spectrum Sliced Free Space Optical System. *Wireless Pers Commun* **100**, 1775–1789 (2018). <https://doi.org/10.1007/s11277-018-5674-9>

- [8] Abdul Gafur & Syed Zahidur Rashid, "Quality Optimization Based Trend Line for Hybrid Optical Amplifier Configurations in DWDM Transmission Systems", INTERNATIONAL JOURNAL OF MICROWAVE AND OPTICAL TECHNOLOGY,, vol. 14, 5, 2019, 2019.
- [9] F. Ajibodu, Zacchaeus Adetona, "Performance Analysis of Erbium Doped Fiber Amplifier's and FWM Characteristics in a Passive Optical Network", International Journal of Optoelectronic Engineering 2016,, vol. 611-7, 2016.
- [10] T. N. Victor jaya, "Performance Analysis of 48 Channels DWDM System using EDFA for Long Distance Communication", GRD Journals- Global Research and Development Journal for Engineering, vol. 2, no. 3, pp. ISSN: 2455-5703, 2017.
- [11] B. M.L. Meena, R.S. Meena, "DESIGN AND PERFORMANCE ANALYSIS OF SEMICONDUCTOR OPTICAL AMPLIFIER FOR 16×10Gbps DWDM TRANSMISSION SYSTEMS", ICTACT JOURNAL ON COMMUNICATION TECHNOLOGY, JUNE 2019, vol. 10, no. 02, pp. ISSN: 2229-6948, 2019.
- [12] R. Dharmendra Dhadhal, "Performance Analysis of 64 Channel DWDM System Using Single Mode Fiber at Different Power Levels and Frequency Spacing", ICMAICT 2020, vol. 1804012153, 2020.
- [13] Ebrahim E. Elsayed, "Performance evaluation and analysis of four waves mixing in DWDM optical communications", Research Square, 2021.
- [14] H. Ullah Manzoor, et al., "FWM Mitigation in DWDM Optical Networks", ICaTAS 2019, vol. 14472020012033, 2019.
- [15] S. Mahdi Hamzah, et al, "Enhancement of the Performance of DWDM Free Space Optics (FSO) Communications Systems Under Different Weather Conditions", International Journal of Intelligent Engineering & Systems, vol. 13, 4, 2020, 2020.
- [16] Lema, Gebrehiwet Gebrekrstos. "Free space optics communication system design using iterative optimization" Journal of Optical Communications, vol. , no. , 2020, pp. 000010151520200007

[17] N. Harjeevan Singh, Prabhjot Singh, "Analyzing the FWM at Different Power Levels in the Fiber Optic DWDM System", DWDMProceedings of the Fifth International Conference on Communication and Electronics Systems (ICCES 2020), vol. 978-1-7281-5371-1, 2020

[18] N. Harjeevan Singh, Prabhjot Singh, "Mitigation of FWM in the Fiber Optic DWDM System by using Different Modulation Techniques and Optical Filters", Proceedings of the Fifth International Conference on Communication and Electronics Systems (ICCES 2020), vol. 978-1-7281-5371-1, 2020

[19] N. Desita D Fadhilah, Suherman, "Point to Point Communication Link Design by Using Optical DWDM Network", 2020 4th International Conference on Electrical, Telecommunication and Computer Engineering (ELTICOM), 2020.