



BACHELOR OF SCIENCE IN ELECTRONIC AND TELECOMMUNICATION  
ENGINEERING (ETE)

**Design and Simulation of Square Split Enclosed Labyrinth Maze  
Shaped Metamaterial Absorber for S-band and Ku-band Applications.**

**Submitted by:**

**Abu Noman**  
T183007

**Supervised by:**

**Mohammed Jashim Uddin**

Associate Professor  
Department of ETE  
International Islamic University Chittagong

**Department of Electronic and Telecommunication Engineering (ETE)**  
**International Islamic University Chittagong (IIUC)**  
**Kumira, Sitakunda, Chittagong**

**July, 2023**

## **DEDICATION**

This thesis work is dedicated to all of our honorable teachers and our beloved parents for their prayers and support towards the achievement of our goal.

## **CERTIFICATE OF APPROVAL**

The thesis entitled as “Design and Simulation of Square Split Enclosed Labyrinth Maze Shaped Metamaterial Absorber for S-band and Ku-band Applications.” Submitted by **Abu Noman** bearing ID No. **T183007**, to the Department of Electronic and Telecommunication Engineering (ETE) of International Islamic University Chittagong (IIUC) has been accepted as satisfactory to partially fulfill the bachelor’s degree criteria in Electronic and Telecommunication Engineering and approved as to its style and contents for the examination held on 15<sup>th</sup> July 2023.

**Approved by:**

**Mohammed Jashim Uddin**

Supervisor and Associate Professor

Department of Electronic and Telecommunication Engineering (ETE)

International Islamic University Chittagong (IIUC)

Kumira, Sitakunda, Chittagong

## CANDIDATES DECLARATION

I hereby declare that the work in this thesis is my own except for quotations and summaries which have been duly acknowledged.

**Abu Noman (T183007)**

## ACKNOWLEDGEMENTS

In the name of Allah, the almighty and most superior, the most gracious and merciful. All praises goes to Allah (SWT) for His eternal blessing, graces and guidance throughout our lives. May peace and blessings of Allah (SWT) be on our beloved Prophet Muhammad (SAAS), who is our ever inspiration. Firstly, I would like to thanks Allah (SWT) for granting me ability and opportunity to accomplish my research. Secondly, I would like to show my sincere gratitude to the supervisor of my thesis, **Engr. Mohammed Jashim Uddin**, for his excellency, invaluable guidance, and motivations towards the completion of my research. I also grateful to my co-supervisor **Dr. Saif Hannan** and Convener **Engr. Abdul Gafur** also Internal Member and Chairman **Engr. Syed Zahidur Rashid** for their continuous support and inspiration throughout my journey. Their technical insight and vision helped me to give proper shape of this thesis. And I remember my parents for their support in my life till now. My sincere thanks go out to my families, friends, well-wishers for their directly or indirectly involvement in the completion of this thesis work.

## ABSTRACT

In this thesis, a multi band metamaterial absorber (MMA) at S and Ku band is presented in microwave frequency band. The unit cell geometry comprises of two split ring resonators and two square shapes structure in the top surface of a FR-4 substrate. Simulation result shown that the structure has multi-band absorption response with S-band and Ku-band. The proposed patch comprises two square split-ring resonators (SSRR) generate five corresponding resonances at 2.44 GHz, 3.57 GHz, 12.039 GHz, 15.516 GHz and 16.713 GHz with 99.4%, 91.65%, 98.75%, 95.37% and 95.77% absorption, respectively. The complex values of permittivity, permeability, refractive index, and surface current were extracted and discussed. The suggested MMA sensor also has a better sensitivity for identifying various hydrocarbons by monitoring changes in the permittivity of the test items. Additionally, the highest reflection band for the MMA sensor arrangement was around 11.28 GHz. The band shift between heptane and octane is 0.01 GHz at its lowest. That the MMA's typical sensitivity for various hydrocarbon compounds is 1.4 GHz/ $\epsilon$ . This MMA's high absorbance makes it suited for a variety of microwave applications, including those for Wi-Fi, mid-range 5G, and hydrocarbon sensing.

# TABLE OF CONTENTS

	Page
DEDICATION	i
CERTIFICATE OF APPEVAL	ii
CANDIDATES DECLARATION	iii
ACKNOWLEDGEMENTS	iv
ABSTRACT	v
LIST OF TABLES	ix
LIST OF FIGURES	x
LIST OF ABBREVIATIONS	xii
<b>CHAPTER 01</b>	<b>INTRODUCTION</b>
1.1	About Metamaterials 1
1.2	Metamaterial Absorber 2
1.3	A Perfect Metamaterial Absorber 2
1.4	Properties of Metamaterial Absorber 3
	1.4.1 Electric Field (E-field) 3
	1.4.2 Magnetic Field (M-field) 3
	1.4.3 Surface Current 4
	1.4.4 Transmission 4
	1.4.5 Reflectance 4
	1.4.6 Absorption 5
	1.4.7 Permittivity 5
	1.4.8 Permeability 6
	1.4.9 Refractive Index 6
	1.4.10 Specific Absorption Rate 7
1.5	5G Communication 7
1.6	5G Frequency Band 8
	1.6.1 Low Band 5G 8
	1.6.2 Mid Band 5G 9
	1.6.3 High Band 5G 9

1.7	Satellite Frequency Band	10
	1.7.1 L-Band	10
	1.7.2 S-Band	10
	1.7.3 C-Band	10
	1.7.4 X-Band	11
	1.7.5 Ku-Band	11
1.8	Wi-Fi	11
1.9	Sensing	12
<b>CHAPTER 02</b>	<b>LITERATURE REVIEW</b>	
2.1	Introduction	13
2.2	Classification of Metamaterials	13
2.3	Microwave Metamaterial Structure	14
	2.3.1 Classification Scheme	14
2.4	Epsilon-negative Metamaterials	15
2.5	Mu-negative Metamaterials	16
2.6	Metamaterial Absorber	17
	2.6.1 Structure of Metamaterial Absorber	17
	2.6.2 Features of Metamaterial Absorber	18
	2.6.3 Single Negative (SNG) Metamaterial Absorber	19
	2.6.4 Near Zero Index Metamaterial Absorber	19
2.7	Frequency Targeted Metamaterial Absorber	20
2.8	Performance Evaluation of Metamaterial Absorber	21
2.9	Challenge of Metamaterial Design and future Development	21
2.10	Previous Work Review	22
2.11	Summary	30
<b>CHAPTER 03</b>	<b>METHODOLOGY AND DESIGN PROCESS</b>	
3.1	Introduction	31
3.2	Research Design	31
3.3	Analysis Method	31
	3.3.1 Research Methodology Design	32
3.4	Metamaterial Absorber Design	33
	3.4.1 Substrate	33

	3.4.2	Patch Design (step 1)	34
	3.4.3	Patch Design (step 2)	35
	3.4.4	Patch Design (step 3)	36
	3.4.5	Patch Design (step 4)	38
	3.4.6	Final Patch view Design	39
	3.4.7	Add waveguide port	40
	3.4.8	Unit cell Design	41
<b>CHAPTER 04</b>		<b>SIMULATION AND RESULT ANALYSIS</b>	
4.1		Introduction	42
4.2		MMA Result Analysis	42
	4.2.1	Reflection Co-efficient	43
	4.2.2	Reflectance	43
	4.2.3	Transmission	44
	4.2.4	Absorption	44
	4.2.5	Absorption, Reflectance & Transmission	45
	4.2.6	Permittivity	45
	4.2.7	Permeability	46
	4.2.8	Refractive Index	46
	4.2.9	Unit cell $S_{11}$ result	47
	4.2.10	MMA E-field	48
	4.2.11	MMA H-field	49
	4.2.12	Surface Current	51
4.3		Hydrocarbon Sensing Application	52
<b>CHAPTER 05</b>		<b>CONCLUSION</b>	
5.1		Introduction	55
5.2		Conclusion	55
5.3		Achievement	55
5.4		Limitation	56
5.5		Future Work	56
<b>REFERENCES</b>			57

## LIST OF TABLE

<b>Table No.</b>	<b>Title</b>	<b>Page</b>
2.1	Summary of findings of some existing frequency-targeted absorber	20
3.1	Parameter of the MMA structure	40
4.1	Metamaterial Absorber properties for the proposed absorber	47
4.2	Hydrocarbon Sensing	52
4.3	Comparison Table	53

## LIST OF FIGURES

<b>Figure No.</b>	<b>Title</b>	<b>Page</b>
1.1	Metamaterial	1
1.2	Metamaterial Absorber	2
1.3	5G Communication	8
1.4	5G Frequency Band	9
1.5	Satellite Frequency Band	10
1.6	Wi-Fi	11
2.1	Classification of Metamaterials	13
2.2	Classification of microwave metamaterial construction	15
2.3	The first MNG-material unit cells: a) round, b) square	16
2.4	Structural view of metamaterial absorber	18
2.5	Absorption by an MMA	18
3.1	Flowchart for metamaterial absorber develop	32
3.2	3D co-ordination view of CST Software	33
3.3	Substrate	34
3.4	A circular ring resonator and subtract design	35
3.5	Another circular ring resonator and subtract design	36
3.6	A square ring resonator and subtract design	37
3.7	Another square ring resonator and subtract design	39
3.8	Final Patch view design	39
3.9	After apply waveguide port	40
3.10	Unit cell design	41
4.1	Reflection Co-efficient result	43
4.2	Reflectance result	43
4.3	Transmission result	44
4.4	Absorption result	44
4.5	Absorption, Reflectance & Transmission	45
4.6	Permittivity	45
4.7	Permeability	46

<b>4.8</b>	Refractive index	46
<b>4.9</b>	Unit cell $S_{11}$ result	48
<b>4.10</b>	MMA E-field for respective frequencies	49
<b>4.11</b>	MMA H-field for respective frequencies	50
<b>4.12</b>	Surface Current for respectively frequencies	51
<b>4.13</b>	(a) $S_{11}$ response of the MMA for different hydrocarbon materials, (b) Peak reflection band response with respect to the dielectric constant of testing materials.	52

## LIST OF ABBREVIATIONS

MM	Metamaterial
MMA	Metamaterial Absorber
PMA	Perfect Metamaterial Absorber
4G	Fourth Generation
5G	Fifth Generation
6G	Sixth Generation
SAR	Specific Absorption Rate
RF	Radio Frequency
MIMO	Multiple Input Multiple Output
Iot	Internet of Things
mm	Millimeter
Gbps	Gigabits per second
ENG	Epsilon Negative
SNG	Single Negative
DNG	Double Negative
DPS	Double Positive
MNG	Mu-negative
PBG	Photonic Bandgap
SRR	Split-ring resonator
ZIM	Zero Index Metamaterial
CRECGR	Couple ring enclosed circular geometric resonator
TE	Transverse Electric

TM	Transverse Magnetic
RCS	Radar Cross-Section
IEEE	Institute of Electrical and Electronics Engineers
Wi-Fi	Wireless fidelity
ITO-FET	Indium Tin Oxide-Polyethylene Terephthalate
LC	Inductance-Capacitance
LCR	Inductance-Capacitance-Resistance
LTE	Long Term Evolution
S-parameter	Scattering Parameter
ADS	Advanced Design System
CSRR	Concentric Split-Ring Resonator
CST	Computer Simulation Technology
dB	decibel
DB-WS	Dual Band Wi-Fi Signal
DB-WSA	Dual Band Wi-Fi Signal Absorber
DRI	Direct Refractive Index
E-field	Electric Field
EM	Electromagnetic
EMC	Electromagnetic Compatibility
EMI	Electromagnetic Interference
EMR	Effective Medium Ratio
FFS-CSRA	Four-Fold Symmetric-Circular Split-Ring Absorber
FF	Filling Factor
FR4	Flame Retardant 4

FSS	Frequency Selective Surface
GHz	Giga Hertz
GSM	Global Systems for Mobiles
H-Field	Magnetic Field
ZIM	Zero Index Metamaterial

# Chapter 01

## Introduction

### 1.1 About Metamaterials

Metamaterials are artificial materials engineered to have specific properties that are not found in natural materials. These properties are typically related to the manipulation of electromagnetic waves, but can also include other phenomena such as acoustic waves and heat transfer. The unique properties of metamaterials are achieved by designing the structure of the material at the nanoscale level, typically using techniques such as lithography, chemical synthesis, or self-assembly. By carefully controlling the size, shape, and orientation of the constituent elements, metamaterials can be made to exhibit properties such as negative refractive index, cloaking, or near-perfect absorption.

One of the defining features of metamaterials is their capacity to manipulate electromagnetic waves in unconventional ways. For example, they have a negative refractive index, which allows for bending of light in unusual directions, or exhibit properties like super lensing, which enables imaging beyond the diffraction limit [1]. These properties arise from the engineered subwavelength structures that can control and manipulate the electric and magnetic fields of the incident waves.

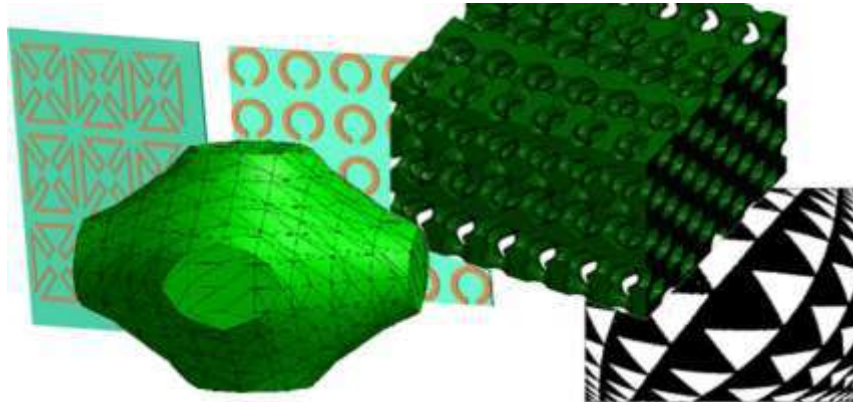

Figure 1.1: Metamaterial [2]

Metamaterials have several applications in fields such as optics, telecommunications, sensing, imaging, and antenna design. They can be utilized to create high-resolution lenses, small antennas, efficient absorbers, waveguides, cloaking devices, and other things. The unique properties of metamaterials continue to drive research and innovation in the field of electromagnetics.

## 1.2 Metamaterial absorber

Metamaterial absorbers are a specific type of metamaterial designed to efficiently absorb electromagnetic radiation in specific frequency ranges. They are engineered to achieve high absorption efficiency by manipulating the interaction between incident electromagnetic waves and the absorber structure.

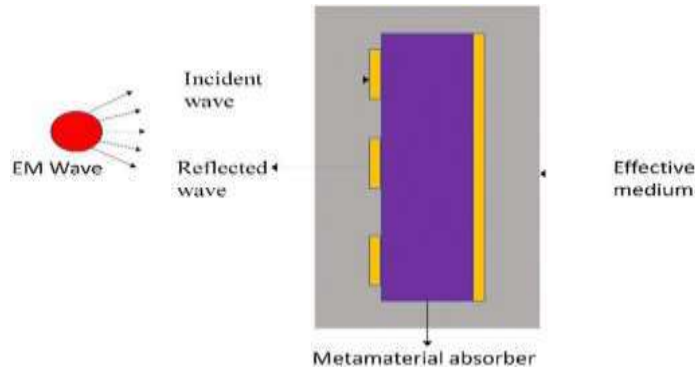

Figure 1.2: Metamaterial Absorber [3]

The design of metamaterial absorbers can be tailored to specific frequencies, making them useful in a variety of applications. For example, they can be used in sensors and detectors to absorb and detect specific wavelengths of light, or in stealth technology to reduce the radar signature of objects. One of the advantages of metamaterial absorbers is that they can be designed to be very thin, making them suitable for use in devices where space is limited. They can also be made to absorb light over a wide range of angles, making them useful in applications where the direction of incident radiation may vary.

Research into metamaterial absorbers is ongoing, and new designs and applications are being explored. Potential future applications include solar cells that can absorb a broader range of frequencies, and metamaterials that can be used to control the flow of heat in electronic devices.

## 1.3 A Perfect Metamaterial Absorber

A perfect metamaterial absorber (PMA) is a type of metamaterial device that can absorb almost all incident electromagnetic radiation in a particular frequency range. Unlike traditional absorbers, which rely on thick and bulky materials, PMAs are designed using metamaterials, which are engineered structures with unique properties that do not occur in natural materials.

The key to the PMA's high absorption efficiency is its ability to trap and dissipate incoming electromagnetic waves within the metamaterial structure. This is achieved by carefully tuning the material's geometry, composition, and resonant frequencies to match the frequency of the incident radiation. When the incoming wave interacts with the PMA, it

induces oscillations in the metamaterial, which in turn generate electric and magnetic fields that cancel out the incident radiation. PMAs have potential applications in many areas, including sensing, energy harvesting, and stealth technology. However, current PMAs are not perfect and typically have limitations in terms of the frequency range and incident angle of the absorbed radiation. Research is ongoing to improve the performance of PMAs and extend their range of applications. [4]

## **1.4 Properties of Metamaterial Absorber**

Metamaterials can be characterized by various parameters that describe their electromagnetic properties. Some important parameters include:

### **1.4.1 Electric Field (E-field)**

In metamaterials, the electric field plays a crucial role in determining their electromagnetic response. The interaction of the electric field with the subwavelength structures or elements of the metamaterial leads to unique and tailored electromagnetic properties.

The influence imposed on an electric charge by other charges nearby is known as the electric field, which is a key idea in electromagnetism. Since it is a vector field with amplitude and direction, it is frequently represented by the sign  $E$ . Because there are electric ions present, electric fields develop. Positive charges generate electric fields that radiate outward from them, whereas negative charges generate fields that radiate inward from them. The size and sign of the nearby charges affect the intensity of the electric field at a specific location in space. A key idea in the study of electricity and magnetism is the electric field, which is used to explain how electric charges behave and interact with one another. It is essential to many real-world processes, such as the creation of electrical networks, running computer equipment, and producing and transmitting electricity. [5]

The electromagnetic characteristics of a metamaterial are greatly influenced by electric fields in this situation. It is possible to design the material's electric field reaction at various frequencies to produce desired characteristics like a negative refractive index, high absorption, or tunable resonant behavior.

### **1.4.2 Magnetic Field (M-field)**

The magnetic field in metamaterials is actively manipulated to achieve tailored electromagnetic responses. Metamaterials can enhance or suppress the magnetic field, exhibit resonant behavior, and confine or localize its energy. These properties enable applications in optics, telecommunications, sensing, and magnetic field control.

The force imposed on a magnetic charge or a moving electric charge by other magnetic fields or electric fields in its vicinity is referred to as a magnetic field, which is a basic notion in electromagnetism. Since it is a vector field with amplitude and direction, it is

frequently represented by the sign  $B$ . Magnetic charges, also known as poles, or the movement of electromagnetic charges cause magnetic fields to form. Magnetic fields are produced by the movement of electric charges, such as electrons traveling through a wire, in the lack of magnetic charges. The passage of current or the orientation of the magnetic poles define the path of the magnetic field at a specific location in space. [6]

### **1.4.3 Surface Current**

Electric current that travels along a conductor's surface rather than through its core is referred to as surface current. It develops because of the conductor's proximity to an electromagnetic field, which causes a current to travel across its surface.

In the study of electromagnetic waves and the behavior of objects in their presence, surface current is a key topic. Surface current is a key factor in defining the electromagnetic characteristics of metamaterials, such as reflectivity, absorptivity, and transmission qualities.

### **1.4.4 Transmission**

A particular frequency or bandwidth of electromagnetic energy can be effectively absorbed by metamaterial absorbers. As a consequence, it is anticipated that the metamaterial absorber will transmit very little at the absorption frequency or spectrum. Alternatively put, it is anticipated that the metamaterial absorber will reduce or stop the incoming electromagnetic radiation at the absorption frequency or bandwidth.

Nevertheless, based on the absorber's design, the metamaterial absorber may still convey the incident radiation with some effectiveness at frequencies outside the absorption frequency or bandwidth. This indicates that the metamaterial absorber's transmission is not zero but can instead be regulated by changing the absorber's construction specifications. [7]

### **1.4.5 Reflectance**

Metamaterial absorbers are made to optimize absorption by minimizing the reflectance of electromagnetic energy in a specific frequency range. A metamaterial absorber's absorption is determined by the design factors that include the substrate's characteristics, the width of the absorber, and the size and makeup of the unit cells.

In principle, it is possible to reduce the light of a metamaterial absorber by increasing the absorption. By creating a metamaterial absorber with a high absorption rate over the required frequency range, this can be accomplished. To avoid introducing undesirable reflections or scattering of the incoming radiation, which could impair the system's performance, the absorber must be carefully positioned. Simulations and actual observations can be used to assess the performance of a metamaterial absorber over a

variety of frequencies and incident orientations in order to build the absorber with the lowest possible reflectance. The reflectance can be reduced while keeping high absorption efficiency by changing the design parameters, such as the unit cell size and makeup, the absorber thickness, and the substrate characteristics. [8]

#### 1.4.6 Absorption

The capacity of a metamaterial construction to efficiently absorb electromagnetic radiation in a particular frequency range is referred to as metamaterial absorber absorption. Utilizing the special qualities of metamaterials artificially created materials that show electromagnetic characteristics not found in natural materials metamaterial absorbers are created to have high absorption effectiveness over a restricted range of frequencies.

The unit cell size and makeup, the absorber width, and the substrate characteristics are some of the design factors that affect how well a metamaterial absorber absorbs. It is possible to create metamaterial absorbers that are selective in their absorption of particular frequencies or that have high absorption effectiveness over a broad range of frequencies by adjusting these factors. Utilizing methods like reflectance and transmittance readings, which can be used to determine the absorber's absorption rate, it is possible to test the absorption effectiveness of a metamaterial absorber empirically. The absorption coefficient, which is frequently stated as a number, is a measurement of the proportion of incident electromagnetic radiation that is received by the absorber. Sensing, imaging, and energy gathering are applications of metamaterial absorbers where effective absorption of electromagnetic radiation in a particular frequency range is needed. [9]

#### 1.4.7 Permittivity

Every material possesses a property called permittivity, which measures the resistance to the formation of an electric field. It is written with the Greek letter  $\epsilon$ . It specifies the number of charges necessary to produce one unit of electric flux in a given medium.

The vacuum characterizes the least possible value of Permittivity. This is commonly known as the Permittivity of Free Space or electric constant, denoted by  $\epsilon_0$  and having the value  $8.85 \times 10^{-12}$  Farad/meter. Even in dielectrics, the opposition to the formation of electric field lines is evident. Relative permittivity refers to the ratio of a dielectric's absolute permittivity to the electric constant, which represents its permittivity [10]. It is a dimensionless quantity and is given as

$$\text{permittivity} = \frac{\text{Electric displacement}}{\text{Electric field intensity}} \quad (1.1)$$

$$\epsilon_r = \frac{\epsilon}{\epsilon_0} \quad (1.2)$$

where,

$\epsilon_0$  is the electric constant

$\epsilon_r$  is the relative permittivity

$\epsilon$  is the absolute permittivity of that material

### 1.4.8 Permeability

Permeability is the ability of a material to permit the formation of magnetic lines of force or a magnetic field. It describes the material's capacity for magnetization in response to an applied magnetic field. In simpler terms, magnetic permeability can be defined as "the extent to which magnetic field lines can enter a substance." or "The ability of a material to conduct magnetic field lines." It is denoted by the Greek alphabet  $\mu$ .

$$\text{permeability} = \frac{\text{Magnitiuide of magnetic induction (B)}}{\text{Intensity of magnetic field (H)}} \quad (1.3)$$

$$\mu = \frac{B}{H} \quad (1.4)$$

For classifying its magnetization property. If its magnetic permeability is less than  $\mu_0$ , the material is diamagnetic. Similarly, a material is considered to be paramagnetic if its magnetic permeability exceeds  $\mu_0$  [10].

### 1.4.9 Refractive Index

Refractive index is the ratio between the speed of light in a vacuum and the speed of light in a particular medium. The term refractive index is also known as refraction index or index of refraction. The properties of a medium determine the speed of light in that medium. The pace of electromagnetic waves depends on the optical density of the medium. Optical density of a material is the tendency of its elements to restore the absorbed electromagnetic energy. The more optical density of a substance, the slower the speed of light. The refractive index is one such indicator of the optical density of a medium.

The refractive index has no dimensions. It is a number that represents how much slower a light wave would be in the substance than in a vacuum [11]. The refractive index, denoted by the symbol  $n$ , is the ratio of the velocity of light in vacuum to the velocity of light in a medium. The refractive index formula is as follows:

$$n = \frac{c}{v} \quad (1.5)$$

Where,

$n$  is the refractive index

$c$  is the velocity of light in a vacuum ( $3 \times 10^8$  m/s)

$v$  is the velocity of light in a substance

#### 1.4.10 Specific Absorption Rate

The rate at which energy is taken by the body in response to electromagnetic radiation, such as that from mobile phones or Wi-Fi devices, is measured by the specific absorption rate (SAR). SAR indicates the quantity of radiofrequency (RF) energy that is absorbed per unit mass of tissue and is usually expressed in watts per kilogram (W/kg).

$$\text{Specific absorption Rate (SAR)} = \frac{\sigma * E^2}{m_d} \quad (1.6)$$

Where,

$\sigma$  = Conductivity of Material,

$E$  = Electric Field (RMS),

$m_d$  = Mass Density.

The SAR value is used to set regulation boundaries for electromagnetic field exposure as well as to assess the safety of RF-emitting equipment. The body absorbs more energy the higher the SAR value, which could possibly damage cells and organs. [12]

It's crucial to keep in mind that SAR values for a device are frequently measured at maximum power levels and worst-case situations, which may not correctly represent actual usage.

### 1.5 5G Communication

5G communication refers to the fifth generation of wireless communication technology that promises faster internet speeds, more reliable connections, and lower latency than previous generations of wireless technology.

It uses a combination of new technologies, such as millimeter-wave frequencies, massive MIMO (Multiple Input Multiple Output), and network slicing, to achieve these improvements. Some of the potential benefits of 5G communication include faster download and upload speeds, reduced latency, and improved network capacity. This could lead to the widespread adoption of new technologies, such as augmented and virtual reality,

autonomous vehicles, and the Internet of Things (IoT), which require fast and reliable wireless connections.



Figure 1.3: 5G Communication [13]

5G technology is being rolled out around the world, but its deployment has been met with some controversy. Concerns have been raised about the potential health effects of exposure to millimeter-wave frequencies, the security of 5G networks, and the potential impact of 5G on jobs and the economy.

Despite these concerns, 5G technology is expected to transform the way we live and work, offering new opportunities for innovation and growth in many sectors of the economy.

## 1.6 5G Frequency Band

5G has three frequency bands: low, medium, and high. Each band has different features: the low band (less than 1GHz) has more coverage but slower speeds, the mid band (1GHz–6GHz) has a good mix of both, and the high band (24GHz–40GHz) has faster speeds but less coverage. 5G can use more frequencies in all three bands to get the best results, and it can even use more than one frequency at once. This makes 5G bands more flexible than previous versions of cellular technology. It also makes coverage and stability better [14].

### 1.6.1 Low Band 5G

Low band 5G is one of the three types of 5G networks, the other two being mid-band and high-band (also known as mm Wave). Low band 5G operates on a lower frequency spectrum, typically below 1 GHz, which provides better coverage and penetration through walls and obstacles compared to mid-band and high-band 5G. Commercially, the low band is used to cover the whole country, and individually, it helps businesses talk to remote job sites. For instance, low-band 5G is used in the energy business to talk to oil fields, mines,

and wind farms that are far away. Future farms that use smart sensors to keep an eye on their crops often use the low band to keep an eye on sensors from far away.

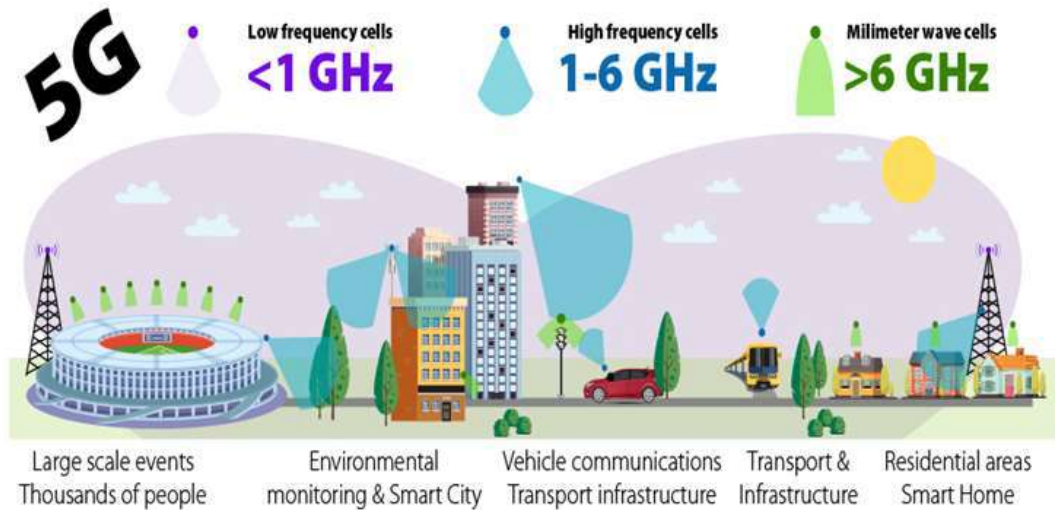

Figure 1.4: 5G Frequency Band [15]

### 1.6.2 Mid Band 5G

It operates on a frequency spectrum typically between 1 GHz to 6 GHz, providing a balance between coverage and speed compared to low-band and high-band 5G.

Mid-band 5G has higher data speeds than low-band 5G, making it ideal for delivering faster internet speeds to densely populated areas such as cities. It can also handle a higher number of connected devices than low-band 5G, making it more suitable for the increasing number of Internet of Things (IoT) devices and smart city applications. In terms of coverage, mid-band 5G has a wider coverage area than high-band 5G, but not as wide as low-band 5G. However, it provides better coverage and faster speeds than 4G LTE.

Overall, mid-band 5G is considered the sweet spot between coverage and speed, and it is expected to become the most widely used 5G spectrum in the coming years.

### 1.6.3 High Band 5G

High-band 5G, also known as mm Wave (millimeter wave) 5G. It operates on a very high frequency spectrum between 24 GHz and 100 GHz, providing very high data speeds but with limited coverage and shorter range compared to low-band and mid-band 5G.

High-band 5G can deliver extremely fast data speeds, up to 10 Gbps, which is much faster than low-band and mid-band 5G as well as 4G LTE. It is ideal for delivering high-bandwidth applications such as augmented and virtual reality, 4K and 8K video streaming, and real-time gaming.

## 1.7 Satellite Frequency Band

The applications for satellite technology are continuously expanding as satellite technology rapidly advances. Satellites are not only used for radio communications, but also for astronomy, weather forecasting, broadcasting, cartography, and numerous other purposes.

### 1.7.1 L-band (1–2 GHz):

This band of frequencies goes from 1 GHz to 2 GHz. It is often used for satellite communications, such as mobile satellite services, global positioning systems (GPS), and some television services.

### 1.7.2 S-band (2–4 GHz):

Several types of weather radar, ship radar, and communications satellites use the S-band (2–4 GHz), including certain NASA satellites used to talk to the International Space Station and the Space Shuttle. The European Commission allotted two separate 2x15 MHz chunks of the S-band to Inmarsat and Solaris mobile.

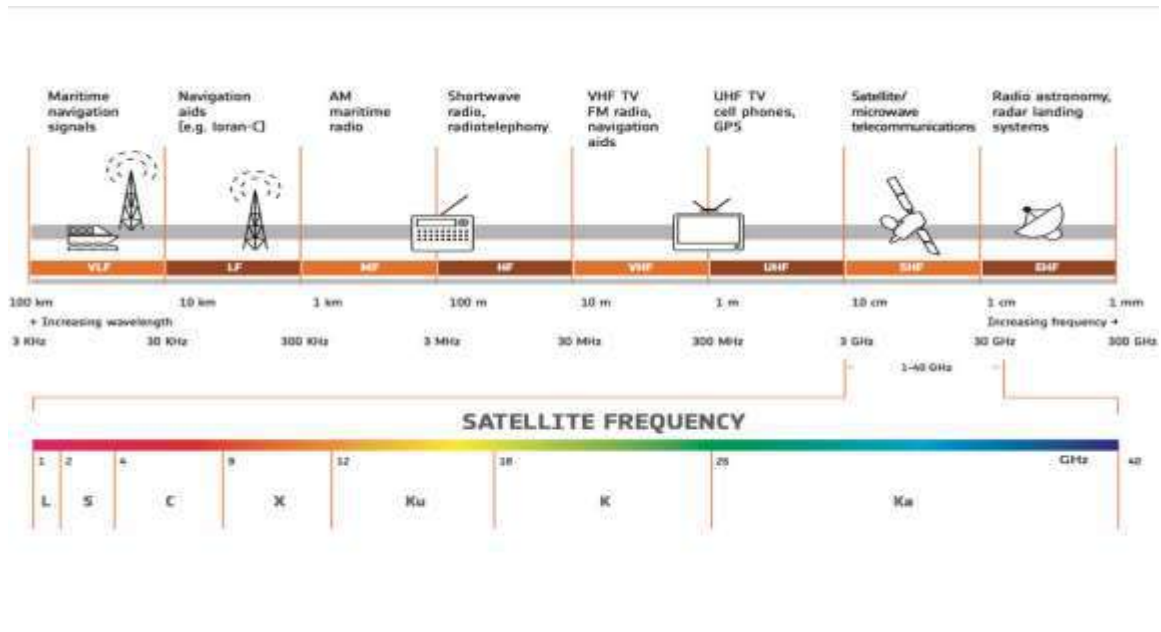

Figure 1.5: Satellite Frequency [16]

### 1.7.3 C-band (4–8 GHz):

For the most part, it is used in satellite communications, namely for permanent satellite television networks or unprocessed satellite feeds. Popular in the tropics because it is less affected by rain fade than the Ku band, which is why it is used so extensively there (the

Original Telstar satellite had a transponder operating in this band, used to relay the first live transatlantic TV signal in 1962).

#### **1.7.4 X-band (8–12 GHz):**

X-band refers to a frequency band commonly used in various applications, including satellite communications, radar systems, and wireless networks. The frequency range for the X-band typically falls between 8 and 12 gigahertz (GHz), which corresponds to wavelengths ranging from 2.5 centimeters to 3.75 centimeters.

#### **1.7.5 Ku-band (12–18 GHz):**

Ku-band (12-18 GHz) is widely used for satellite communication, including DTH TV broadcasting, VSAT communication, and high-speed internet access. It offers higher data rates but can experience signal degradation during heavy rain. Ku-band enables smaller antennas, making it popular for consumer applications and mobile communication on ships and planes. To send and receive messages by satellite. Direct broadcast satellite services, such as Astra, utilize the Ku-band downlink frequency range in Europe, which is between 10.7 GHz and 12.75 GHz. [16].

### **1.8 Wi-Fi**

Wi-Fi is a wireless technology that connects devices to the internet and allows them to communicate wirelessly. It uses access points and client devices and operates in the 2.4 GHz or 5 GHz bands. For security, Wi-Fi networks use authentication and encryption. The range is determined by things such as equipment and impediments. Wi-Fi protocols such as 802.11b, 802.11n, and Wi-Fi 6 improve speed and performance. Wi-Fi is widely utilized in diverse situations for wireless internet access.



Figure 1.6: Wi-Fi [17]

There are Wi-Fi networks in many public locations, including buildings like residences, workplaces, colleges, and airports. In comparison to wired networks, they have a number

of benefits, such as ease, portability, and scaling. They do, however, have some drawbacks, including restricted range, a vulnerability to interference, and possible security threats.

A device needs a Wi-Fi adapter or chipset as well as the proper details, such as a network identity (SSID) and password, in order to join to a Wi-Fi network. (Security key). The gadget can interact with other connected devices and access the internet once it is connected.

## **1.9 Sensing**

Sensors are fundamental components that enable the measurement and detection of various physical, chemical, and biological phenomena. They find applications in numerous fields, contributing to advancements in technology, automation, healthcare, and environmental monitoring. With ongoing research and technological developments, sensors are expected to become even more versatile, intelligent, and integrated into our daily lives. Sensor technology continues to advance, leading to improvements in performance, miniaturization, and integration capabilities. Some recent advancements include:

**Miniaturization:** Sensors are becoming smaller, enabling integration into portable devices, wearables, and implantable medical devices.

**Wireless Connectivity:** Sensors are equipped with wireless communication capabilities, enabling real-time data transmission and integration into networked systems.

**Chemical:** Sensors employ various chemical reactions or interactions to detect and measure specific gases, liquids, or biological substances.

**Optical:** Sensors detect and quantify light intensity or wavelength using mechanisms such as photodiodes, phototransistors, or optical fibers. [18]

# Chapter 02

## Literature Review

### 2.1 Introduction

Metamaterial absorbers have emerged as promising devices for a wide range of applications due to their unique electromagnetic properties and efficient energy absorption capabilities. This literature review aims to provide a comprehensive overview of the research and developments in metamaterial absorbers for various applications.

This chapter reviews the design of metamaterials (MM) and MMA with fundamentals including definition, standards, advantages, and applications. The fundamental parameters that always must be considered during MMA designs, such as the negative value of permittivity or permeability, refractive index, periodicity of the unit cell, reflection and transmission coefficients, absorption performance, are also described in this chapter.

### 2.2 Classification of Metamaterials

Metamaterials can be put into two main groups based on how they can be described mathematically. In the first group are DNG and SNG structures. In the second group are PBG structures, also called photonic crystals or photonic bandgap materials.

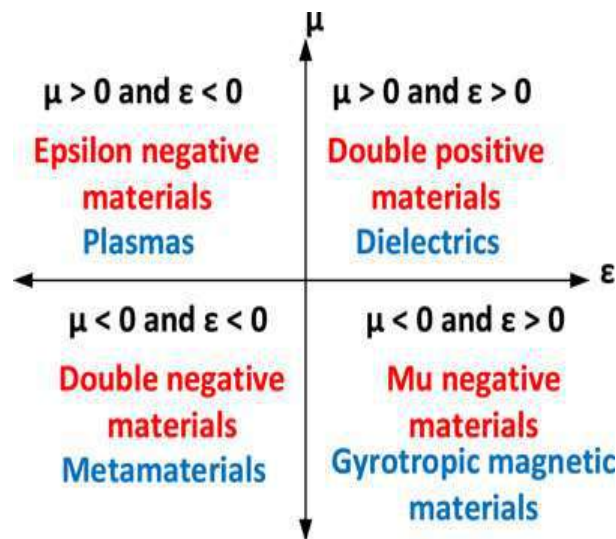

Figure 2.1: The general classification of physical materials depending on the values of permittivity and permeability [19]

The first group is called "double positive" (DPS) materials because both  $\epsilon$  and  $\mu$  of the material are bigger than zero. Most of the things in this group are dielectrics. In the second

group, the permittivity is less than zero and the permeability is greater than zero. This is why it is called an epsilon negative (ENG) material. At certain frequencies, this is true of a lot of plasmas. Materials in the third group have a permittivity that is greater than 0 and a permeability that is less than 0. These are the traits of mu negative (MNG) materials, which are gyro tropic magnetic materials. The double negative (DNG) materials, which can only be made in artificially, are in the fourth group.

This type of material has both a negative (less than zero) permittivity and a negative (less than zero) permeability. When an EM wave enters of these materials, the way the wave moves changes. There is no material in nature that has both a negative permeability and a negative permittivity. From the above list, we can say that metamaterials are a special type of material that is made to have negative permittivity and negative permeability [20]-[24]. However, as more structures with unique properties and applications are designed and developed, a broader definition is used to classify them as metamaterials. The metamaterial is a man-made macroscopic composite with a periodic cellular architecture designed to produce a complex interaction with electromagnetic waves in order to accomplish the desired performance, which cannot be obtained using naturally occurring material [25], [26].

### **2.3 Microwave Metamaterial Structure**

Microwave metamaterial structures are materials that have been purposefully manufactured to have unique electromagnetic characteristics that are not present in naturally occurring materials. These structures are made up of regular groupings of subwavelength components such split-ring resonators, metallic wires, and dielectric resonators.

Metamaterials are frequently created to influence electromagnetic waves in ways that ordinary materials cannot. They can have qualities such as a negative refractive index, which allows for extraordinary light bending, or perfect absorption, which allows for efficient energy absorption across a broad range of frequencies. Metamaterial structures can be utilized in a variety of applications involving microwave frequencies, including antenna design, electromagnetic wave manipulation, cloaking devices, radar technology, and wireless power transfer.

#### **2.3.1 Classification Scheme**

Metamaterials can be divided into two major classes due to approach to a mathematical description. The first class includes DNG and SNG- structures, whereas the second is PBG-structures or photonic crystals that also termed as photonic bandgap materials

As were mentioned above, the linear size of internal inclusions in DNG and SNG-materials is much smaller than the operating wavelength. Thus such media generally are lead to

homogeneity and described with the concept of effective medium. The distance between the constituent elements in PBG-structures is equal to about half the wavelength or more.

Therefore, photonic crystals cannot be considered as homogeneous media. They are usually described by Bragg reflection, which don't have an important role in DNG and SNG structures, and other approaches to periodic media are used.

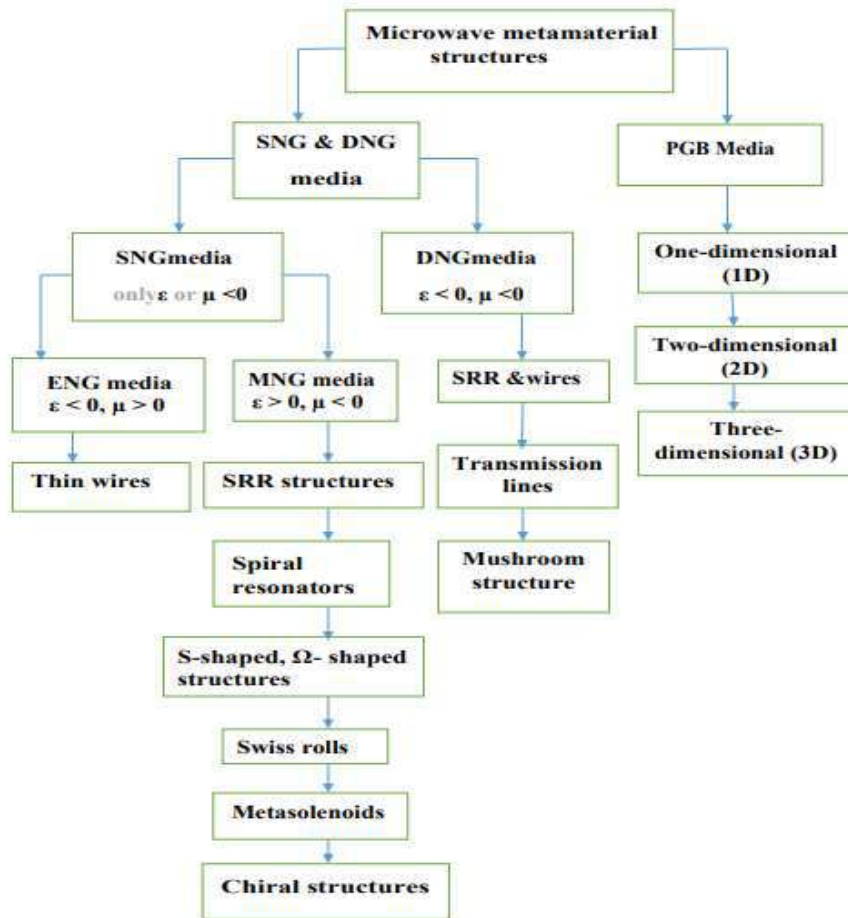

Figure 2.2: Classification of microwave metamaterial construction [27]

After analyzing papers and monographs, which highlighting the basic metamaterial strategies for microwave applications, classification scheme shown in Fig. 2.2 have been made. [27]

## 2.4 Epsilon-negative Metamaterials

Epsilon-negative (ENG) metamaterials, also known as negative permittivity materials, are a type of artificially engineered material designed to exhibit a negative value of permittivity ( $\epsilon$ ). In natural materials, permittivity is a positive value, indicating the ability of a material to store electrical energy in an electric field. However, ENG metamaterials have been

engineered to possess a negative permittivity, resulting in unusual electromagnetic properties [28]. The metamaterial used as a metallic mesh of thin wires for obtaining negative value of  $\epsilon$ . The effective permittivity can be expressed as

$$\epsilon_p = 1 - \omega_p^2 / \omega^2 \quad (2.1)$$

Where  $\omega_p$  is the plasma frequency and  $\omega$  is the frequency of the propagating electromagnetic wave. From this equation, the effective permittivity is negative when the frequency is below the plasma frequency. When operating at the plasma frequency, the effective permittivity is zero, and hence yields a zero index of refraction [29].

The negative permittivity in ENG metamaterials arises from the unique arrangement of their constituent elements. These materials often consist of subwavelength components that have been specifically engineered to interact with electromagnetic waves, such as splitting resonators or metallic resonators. The negative permittivity response is caused by this constructed configuration. ENG metamaterials have received a lot of interest because of their capacity to show anomalous characteristics like negative refraction. When electromagnetic waves pass through an ENG metamaterial, they bend in the opposite way as they would in regular materials. This characteristic has uses in lensing, imaging, and wave manipulation.

## 2.5 Mu-negative Metamaterials

Mu-negative (MNG) metamaterials, also known as negative permeability materials, are artificially engineered materials designed to exhibit a negative value of permeability ( $\mu$ ). MNG metamaterials are often combined with epsilon-negative (ENG) metamaterials to create double-negative (DNG) metamaterials, which have applications in antennas, cloaking devices, and wave manipulation.

A few unit cells geometries of MNG-material based on the SRR are shown on Fig.2.3

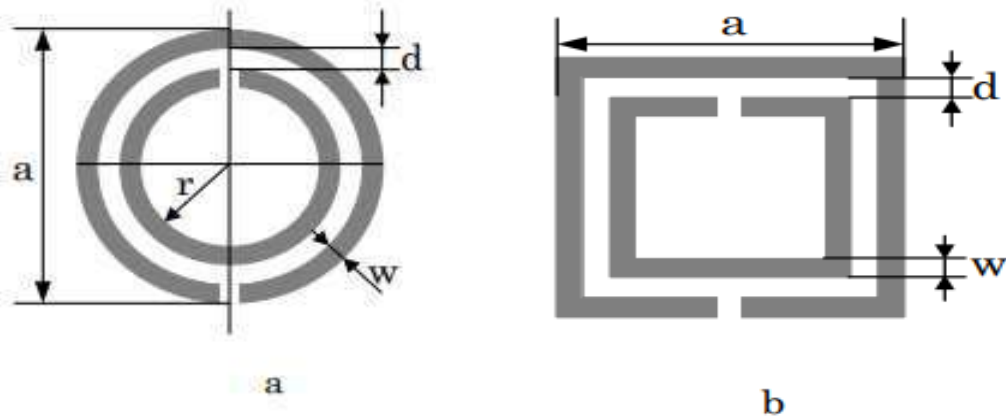

Figure 2.3: The first MNG-material unit cells: a) round, b) square

Split-ring resonator (SRR) is the earliest and most extensively utilized MNG-structure. SRRs, which can be round or square in geometry, are high-conductive resonant structures in which the capacitance between the two rings balances the inductance. A perpendicularly applied time-varying magnetic field causes currents that form the secondary magnetic field. Depending on the structure's resonant qualities, it can either oppose or enhance the incident field, resulting in positive or negative  $\mu_{\text{eff}}$  [27].

## **2.6 Metamaterial Absorber**

Metamaterials are artificial structures with engineered properties that are not available in nature and thus can control EM waves [30]. Usually, MMs consist of a dielectric substrate with metal laminations on the top side or both sides of the substrate. The metal layers are designed with various structures with strip line and capacitive gaps. MM can exhibit negative permittivity or permeability and refractive index values, which can influence the EM propagation along the dielectric medium of antenna, radar, or microwave sensors. The macroscopic effects in the effective permittivity or permeability are significantly endorsed by the engineered metal laminations over the dielectric layer that causes such artificial MM properties. MM is called SNG (single negative) or DNG (double negative) material if it exhibits single negative value or double negative values of permittivity and permeability of the dielectric substrate upon applied EM waves [31].

On the other hand, metamaterial absorbers (MMA) are those artificial structures that can effectively absorb the incoming EM waves and show either SNG or DNG properties at the resonance frequencies. Depending on the metal patch structure and symmetry, MMA can be a perfect absorber or polarization converter (or partial absorber). A MM may or may not have a ground metal layer, but an MMA may have a metal ground layer in most cases.

### **2.6.1 Structure of Metamaterial Absorber**

In most cases, MMA has both the patch (the metallic resonator on the top surface) and the ground (on the bottom surface) metal laminations with a single or multi-layered dielectric substrate layer in between the metal surfaces. Usually, annealed copper, gold, silver etc., are used as metal laminating surfaces on the substrate. The substrate may be solid or liquid dielectric materials. A generalized view of an MMA is shown in figure (2.4):

The EM waves are allowed to pass through the MMA from any direction, and the absorber is supposed to absorb the EM waves effectively at its resonance frequencies.

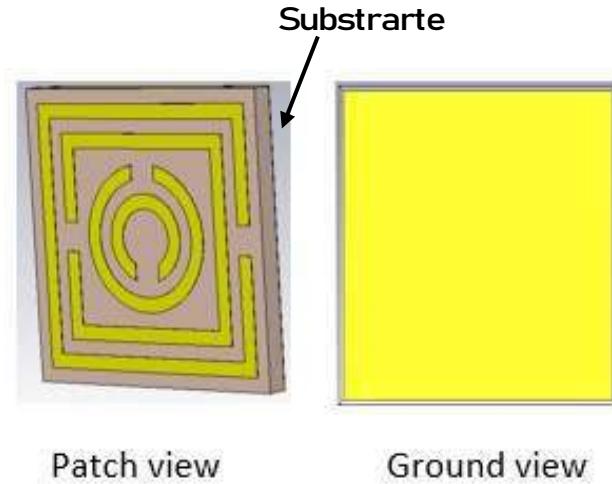

Figure 2.4: structural view of metamaterial absorber

### 2.6.2 Features of Metamaterial Absorber

The general equation evaluates MMA for EM wave absorption.

$$A = 1 - |s_{11}|^2 - |s_{21}|^2 \quad (2.3)$$

The reflection coefficient is the ratio of the reflected wave to the incident wave, and the transmission coefficient is the ratio of the transmitted wave to the incident wave. The reflection coefficient is denoted by  $|s_{11}|^2$  and transmission coefficient is denoted by  $|s_{21}|^2$ . An idea of MMA can be understood from figure

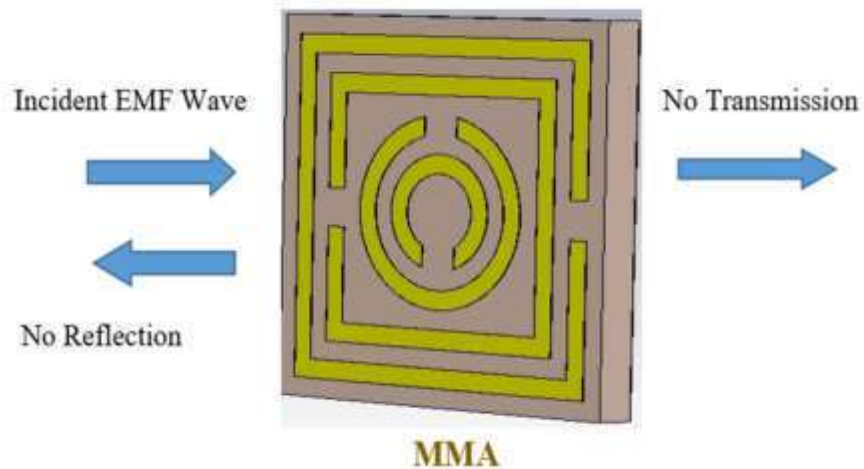

Figure 2.5: Absorption by an MMA

Usually, two waveguide ports are used on both surfaces of the MMA to determine the S parameters. The scattering (S) parameters ( $s_{11}$  and  $s_{21}$ ) can be understood as follows:

$$S_{11} = \frac{\sqrt{\text{power reflected from port1}}}{\sqrt{\text{power reflected from port2}}} \quad (2.4)$$

$$S_{21} = \frac{\sqrt{\text{power reflected from port2}}}{\sqrt{\text{power reflected from port1}}} \quad (2.5)$$

The S parameters can be defined in terms of electric field (Liu et al. 2012). The computed electric field,  $E_c$  on the port consists of the excitation plus the reflected field.

Where there is no reflection and no transmission of applied EM waves from the MM, it acts as MMA. An MMA not only absorbs EM waves but also shows a negative value of permittivity or permeability, leading to a negative refractive index. This property can't be found in nature in general and is thus known as metamaterial characteristics [32].

### 2.6.3 Single Negative (SNG) Metamaterial Absorber

Metamaterials with either negative permittivity or permeability are called single negative (SNG) metamaterials. SNG metamaterials are classified as epsilon negative (ENG) and Mu-negative (MNG) metamaterials. Metamaterial, which exhibits negative permittivity and positive permeability, is called epsilon-negative metamaterial. The ionospheric plasma layer exhibits negative permittivity at radio frequencies, and natural plasmatic materials show this behavior at optical frequencies. Metamaterial, which exhibits positive permittivity and negative permeability, is called Mu-negative metamaterial. Ferromagnetic materials exhibit negative permeability in the higher frequency bands. A wave reflection experiment was done before using one slab of ENG and one slab of MNG material. The experiment results from resonances, transparency and zero reflection. The effective properties of dispersive SNG metamaterials change with the variation in frequency. As mentioned earlier, the absorber with any of the properties is known as SNG MMA.

### 2.6.4 Near Zero-Index Metamaterial Absorber

Metamaterials that exhibit both permittivity and permeability are simultaneously or individually equal to zero at a specific frequency is, called zero-index metamaterials (ZIM). The wave enters in a quasi-infinite phase velocity and infinite wavelength in zero refractive index media. It also provides a quasi-uniform phase of electromagnetic waves because the dipole inside this metamaterials oscillates in unison. Therefore, such media exhibits high directional waves and causes almost no phase shift [33]. Zero index metamaterials can be used to make the far-field pattern narrower of antenna. It can create a radiation field with a uniform phase, which gives a highly directional and collimated outgoing beam at an extended planer surface [34]. The ZIM also enhanced the directivity of the micro strip patch antenna by controlling the direction of emission [35].

The zero-index metamaterial is also categorized as epsilon near zero (ENZ) and Mu near-zero (MNZ). Metamaterial with a real permittivity value close to zero is called epsilon-

near-zero (ENZ) metamaterial. Similarly, metamaterial having a real value of permeability close to zero is called Mu near-zero (MNZ) metamaterial. This type of metamaterial can be adopted for spatial filtering [36], enhancing radiation directivity [37] and for coupling and squeezing EM energy [38]. The fast-wave propagation with inherent negative polarizability, ENZ metamaterials can be used in transparency and cloaking applications [39].

## 2.7 Frequency Targeted Metamaterial Absorber

Usually, MMA is designed with some patterned patch design to get maximum absorptions at the resonance frequencies. In most cases, the resonance frequencies found are some anonymous frequencies, which are mostly not helpful because they are not targeted at real-world or practical application-oriented allocated frequencies.

Moreover, these metamaterials can neither explain the reason for founding the resonances nor relate any relation between the resonance frequencies and the design parameters. Thus frequency-targeted MMA is rare to find. A summary of some existing frequency-targeted MMA is presented in table 2.1

A frequency targeted MMA is designed in such a way that it can show resonance (with both metamaterial characteristics and maximum absorptions) at desired frequencies so that it can be employed for real-world applications.

To get such MMAs, there should be some mechanism and some formula to design and get the desired outputs. The structural parameter is one of the most essential factors in designing frequency-targeted MMA. The purpose of a frequency-targeted metamaterial absorber is to achieve efficient absorption of electromagnetic waves within a narrow frequency range. It is accomplished by tailoring the geometry, size, and composition of the metamaterial structures to interact with the incident waves in a way that maximizes absorption at the desired frequency.

Table 2.1 Summary of findings of some existing frequency-targeted absorbers

Ref. No.	Unit cell Design	Resonance Frequencies (GHz)	Substrate and thickness	Polarization angle insensitivity	Application	Observation
[40]	34 mm (0.27 $\lambda$ )	2.4 & 5 GHz	FR4 (3.2 mm)	Not reported	Wi-Fi absorption	Comparatively large dimension, multi-layered substrate with no MM properties

[41]	40 mm (0.29 $\lambda$ )	2.2-5.85 GHz	ITO-PET (11 mm)	90°	Wi-Fi absorption	Multi-layered transparent substrate for wide absorption and no MM properties
[42]	18 mm (0.14 $\lambda$ )	2.4 & 5.1 GHz	Rogers RO 3003 (1.75 mm)	90°	Crowd estimation in Wi-Fi area	Multi-layered substrate and lumped element in patch for RF energy harvesting, no MM properties
[43]	14 mm	1.246, 3.794 & 4.858 GHz	FR4 (1.6 mm)	45°	SAR reduction	Not perfect absorption and MM properties at undefined 5G frequencies
[44]	24 mm (0.29 $\lambda$ )	3.65, 7 & 11.07 GHz	FR4 (6.8 mm)	45°	RCS reduction	Multiple frequency-targeted MMA with lumped element in patch and thick substrate
[45]	9 mm (0.21 $\lambda$ )	7, 16 & 22 GHz	F4B (3 mm)	75°	RCS reduction	Multiple frequency-targeted absorbers with no specific practical applications

## 2.8 Performance Evaluation of Metamaterial Absorber

The MMA, once designed, should undergo performance evaluation before proposing for potential practical applications. There are many applications of MMA in the EM communication field. Each application requires some specific EM response at some desired frequencies, which can be served these MMAs. To propose an MMA for a particular application like radar cross-section reduction, EM coupling reduction, microwave sensing, EM cloaking, directivity enhancement in high-frequency antennas, and so on, the MMA should be evaluated first. There are some parameters for the performance evaluation of the absorber. The EM behavior of the absorber should be characterized by a proper equivalent circuit approach. Finally, the absorber should be fabricated as both the *unit* cell and array to measure practically and propose potential application.

## 2.9 Challenge of Metamaterial Design and future Development

It is clear from the discussions in the previous sections that designing MMA for arbitrary resonance frequencies is easy but doing the same for practical application based frequency targeted MMAs are rare to find. The age of arbitrary MMA designing has passed as MMA

should be proposed for practical applications. There are no such examples available in recent literature where the actual application or IEEE allocated frequency-oriented MMA are found. Moreover, frequency-selective perfect MMA are also a few in numbers. No technique or formula is available to design frequency or application targeted MMA. The MM properties are also found luckily from all the proposed absorbers, where tailoring these properties to resonance frequencies are impossible to get. Since commercially available substrate materials are mainly used for MMA designing, there should be some engineering method or formula to design definite frequency targeted MMAs using such substrates. MM or MMA have become potential technology to enhance the desired performance of communication systems; thus, engineering these MM is a timely demand for this decade.

Broadband absorption can be easily achieved by applying lumped elements into the patch structure or using multi-layered substrates. Still, such absorbers are not useful for practical applications due to the absence of MM properties at the required frequencies. It is impossible to get MM properties over the whole operating frequencies of these so-called broadband absorbers. MM properties such as SNG or DNG are only found at some isolated frequencies, neither in narrowband nor in broadband span. Due to such limitations, only sharp absorption peaks with MM properties are useful for practical applications. Thus, the use of lumped elements or multi-layers is not encouraged. Moreover, there may be some mechanical problems due to these lumped elements or multi-layered substrates like unsmooth patch surface may get damaged by surface friction or any unwanted accident and lose any of the lumped elements, the excess thickness of the multi-layered substrate may be a problem along with intra-layer dislocation due to ungluing by heating. These shortcomings can only be avoided using MMAs with no-lumped elements in the unit cell patch and a single substrate layer.

Thus, the future of MMA design may lead to a single-layered and lumped element free, practical application or frequency targeted, subwavelength sized, frequency-selective perfect metamaterial absorber. Such absorbers should be conceived from some technique or formula that can help engineer the MM properties at desired levels. It is the same as designing frequency-targeted antennas with desired values and properties to serve our needs and purposes.

## **2.10 Previous work review**

This section will evaluate the relevant works of other researchers to this thesis, Square Split Enclosed Labyrinth Maze Shaped Metamaterial Absorber for Sensing, Wi-Fi and Mid-range 5G Applications.

### **1) Microwave metamaterial absorber for sensing applications.**

A metamaterial absorber (MA) based sensor is designed and analyzed for various important applications including pressure, temperature, density, and humidity sensing. Material

parameters, as well as equivalent circuit model have been extracted and explained. After obtaining a perfect absorption (PA) at around 6.46 GHz and 7.68 GHz, surface current distributions at resonance points have been explained. Since bandwidth and applicability to different sensor applications are important for metamaterial sensor applications, we have realized distinctive sensor demonstrations for pressure, temperature, moisture content and density and the obtained results have been compared with the current literature. The proposed structure uses the changes on the overall system resonance frequency which is caused by the sensor layer's dielectric constant that varies depending on the electromagnetic behavior of the sample placed in. This model can be adapted to be used in sensor applications including industrial, medical and agricultural products. [46]

## **2) Applications of metamaterial sensors: A Review.**

Sensors based on metamaterial absorbers are very promising when it comes to high sensitivity and quality factor, cost, and ease of fabrication. The absorbers could be used to sense physical parameters such as temperature, pressure, density as well as they could be used for determining electromagnetic properties of materials and their characterization. In this work, an attempt has been made to explore the various possible applications of these sensors. Metamaterial-based sensors are very popular for its diverse applications in areas such as biomedical, chemical industry, food quality testing, and agriculture.

Split-ring resonators with various shapes and topologies are the most frequently used structures where the sensing principle is based on electromagnetic interaction of the material under test with the resonator. Overcoming the design challenges using metamaterial sensors involving several constraints such as cost, compactness, reusability, ease in fabrication, and robustness is also addressed. [47]

## **3) Metamaterial Absorber Based Multifunctional Sensor Application.**

In this study metamaterial based (MA) absorber sensor, integrated with an X-band waveguide, is numerically and experimentally suggested for important application including pressure, density sensing and marble type detecting applications based on rectangular split ring resonator, sensor layer and absorber layer that measures of changing in the dielectric constant and/or the thickness of a sensor layer. Changing of physical, chemical or biological parameters in the sensor layer can be detected by measuring the resonant frequency shifting of metamaterial absorber based sensor. Suggested MA based absorber sensor can be used for medical, biological, agricultural and chemical detecting applications in microwave frequency band. We compare the simulation and experimentally obtained results from the fabricated sample which are good agreement. Simulation results show that the proposed structure can detect the changing of the refractive indexes of different materials via special resonance frequencies, thus it could be said that the MA-based sensors have high sensitivity. Additionally due to the simple and tiny structures it could be adapted to other electronic devices in different sizes. [48]

#### **4) Sensory applications of resonator based metamaterial absorber.**

Metamaterials are attractive media for scientific society for their potential multi-functional and a wide range of applications due to their unusual electromagnetic properties. In this paper, we present several important applications including pressure, density and volumetric moisture sensing based on rectangular split ring structure with a strip line. These applications are carried out experimentally and numerically. Since the sensing ability is mostly connected with the resonance frequencies, we have carefully selected a frequency range where the resonance shifts occur linearly depending on the pressure and the density of the medium or material to be tested. The proposed model can be used for chemical, agricultural, medical and biological sensing applications in the microwave frequency band. The model is composed of a split ring resonator (SRR) topology and the sensing layer sandwiched between the SRR and a rectangular copper layer located at the background. Middle-sensing layer changes its dielectric behavior linearly depending on the pressure and the density allowing us to determine the unknown values of these parameters. [49]

#### **5) Design of a seven-band perfect metamaterial absorber for THz sensing applications.**

This paper presents the design of a perfect metamaterial absorber Tera-Hertz (THz) frequencies. The proposed absorber is developed using a square loop enclosing a highly convoluted swastika element. The arms of the swastika elements are coiled to create a square spiral configuration to increase the electrical length of the resonator without increasing the size of the unit cell absorber. The proposed unit cell has multiabsorption characteristics with absorption peaks at 0.82, 1, 1.24, 1.54, 1.85, 2.2 and 2.5 THz. The corresponding absorptivity is greater than 80% in all the reported frequencies. The electrical size of the proposed absorber is  $0.42\lambda_{\text{eff}} \times 0.42\lambda_{\text{eff}}$ , where  $\lambda_{\text{eff}}$  is the effective wavelength calculated at 0.82 THz. The proposed absorber has structural symmetry and has identical absorption spectra for both TE and TM modes of operation. The angular stability is investigated, and the performance is stable for the angles of incidence up to  $70^\circ$ . The proposed absorber has a small frequency ratio and can be used for THz material sensing. The prototype absorber as a sensor is simulated, and the results are presented. [50]

#### **6) Metamaterial Absorber Based Multifunctional Sensor Application.**

In this study we investigate the different MA based sensor applications as density, pressure and marble type detection applications conducted for analyzing sensing capabilities of the suggested design. In order to show the sensing capabilities of the proposed design, density sensor application has been tested experimentally. It can be seen that experimental results are well consistent with the numerical results. The linearly shifting of the resonant frequency depends on the absorption level. . Simulation results show that proposed sensor can be used for different sensing applications when different kind of materials placed in

the sensor layer. These materials that can be selected from linearly changes the results of a sensor design depending on the detection parameters such as humidity, temperature, etc. As an application addition to pressure and density sensor applications, marble type sensor application is performed and analyzed in detail. The result showed that MA based sensor can be used as marble type sensor. [51]

#### **7) SNG and DNG meta-absorber with fractional absorption band for sensing application.**

In summary, a metamaterial absorber is proposed using a tunable microwave frequency (X band) for moisture sensing. Hygroscopic fiber such as cotton slab is used between two-unit cells MRMA. Its performances, triple fractional bandwidth absorption is above 90% in simulation, whereas approximately it is 80% absorption with two wideband during measurement. The complex structure of the absorber ensures perfect metamaterial property with a minimal value of backward propagation (DNG at 12.8 GHz, SNG at 10.62 GHz, and 11.64 GHz) for modified dielectric characteristics leading to perfect EM absorption. Besides, two RT 5,880 PTFE substrates sandwiched with cotton slab boost the potentiality of application since the combined structure relates a high-frequency microwave field and trending or retain moisture capacity. Besides, simulated moisture sensing depicts two independent resonance frequency changes,  $f_1$  (8.4–8.9 GHz) and  $f_2$  (10.6–12.4 GHz) with moisture level variation on the slab, which might be useful to detect moisture in the capsule container. This nature of the metamaterial absorber may have other potential prospects in a variety of commercial products in the X band, wireless humidity sensors use a low-cost solution. [52]

#### **8) A Novel 5G Wideband Metamaterial Based Absorber for Microwave Energy Harvesting Applications.**

In this study, the designed absorber is compact and thin. It could be applied to microwave energy harvesting applications. The work focused on a novel wideband MPA with various incident angles in the range between  $0^\circ$  -  $30^\circ$ . The unit cell is developed and simulated based on the superposition of two resonances generated by two different letters (G and S). Moreover, it offers high absorptivity rate with different dielectric materials. The absorptivity rate is higher than 96% in FR-4 with a substrate height of 1.2 mm and 99% for Rogers RT5880 with a substrate height of 1.575 mm. In future work this study could be validated by fabrication and measurements and its application could be extended to be applied to UAV devices with microwaves energy harvesting based systems. [53]

#### **9) Polarization insensitive dual band metamaterial with absorptance for 5G sub-6 GHz applications.**

A couple ring enclosed circular geometric resonator (CRECGR) based dual-band polarization insensitive metamaterial (MM) with high effective medium ratio (EMR), and

excellent absorptance is proposed in this study, which can be utilized as a sensor and absorber in the 5G sub-6 GHz frequency range. A circular geometry-based unique patch has been introduced in the proposed unit cell to achieve high polarization insensitive properties with excellent absorption for the 5G sub-6 GHz spectrum. The distinctive feature of this proposed CRECGR unit cell is its simple and unique structure with a high EMR of 11.13, polarization insensitive up to  $180^\circ$ , and epsilon negative (ENG) properties, including a negative refractive index and near-zero permeability for 5G sub-6 GHz applications. Furthermore, this designed unit cell yields excellent absorption properties with high quality factor. The designed MM unit cell is fabricated on low loss Rogers RT5880 printed media with an electrical dimension of  $0.089\lambda \times 0.089\lambda \times 0.017\lambda$ . The performance of the designed CRECGR metamaterial is determined using Computer Simulation Technology (CST), Advanced Design Software (ADS), and measurements. The CRECGR unit cell offers dual resonances at 3.37 GHz and 5.8 GHz, covering the 5G sub-6 GHz band with ENG, near-zero permeability and negative index. The polarization insensitive properties of the unit cell were also investigated for maximum angle of incidence, which confirmed the identical response. The simulated outcome is verified by experiment with excellent accordance. Moreover, the unit cell performance with a complete backplane is explored, noting a maximum absorption of 99.9% for all normal and oblique incidence waves, suitable for sensing and antenna systems. In addition, the suggested unit cell sensing performance is evaluated using the permittivity-based sensing model. The proposed MM outperforms recent related studies in terms of polarization insensitivity up to  $180^\circ$ , high insensitive absorptivity, high EMR, and sensing applications. These features prove that the proposed CRECGR metamaterial is perfect for 5G Applications. [54]

#### **10) Metamaterial Based Multiband Micro strip Patch Antenna for 5G Wireless Technology-enabled IoT Devices and its applications.**

In the present era of the digital world, demand for IoT based smart devices has seen tremendous growth. These devices involve real-time human-to-machine communication and interaction. Communication of uninterrupted quality depends on the high bandwidth and speed of the internet. The development of 5G wireless network technology is the response to the crucial factors that lead to this demand, because of its ability to provide extremely fast internet speed, high bandwidth, high performance, reduced latency, and high reliability. In this research work, the authors have developed a metamaterial-based multi-band micro strip rectangular shape patch antenna with a wide high-performance bandwidth because of the demand. The proposed design has a low dielectric constant of 2.2, which is of Rogers RT/Droid substrate, and a dielectric loss tangent of 0.0010. The design has a resonant frequency of 26 GHz. The simulations carried out using FEKO software has been analyzed for performance. The simulation and analysis reveal a good return loss of -34.4 dB at 26 GHz, -13.49 dB at 40 GHz, -13.63 dB at 53.5 GHz, high bandwidth of 5.368 GHz

at 26 GHz, 3.76 GHz at 40 GHz, 2.88 GHz at 53.5 GHz, desirable voltage standing wave ratio,  $1 \leq \text{VSWR} \leq 2$ , high gain of 10 dBi at 26 GHz, 5 dBi at 40 GHz, and high antenna radiation efficiency of 99.7 % at 26 GHz, and 61% at 40 GHz, 50% at 53.5 GHz. The bandwidth, return loss, antenna radiation efficiency and power density indicate an improvement of 5.368 GHz to 5.630 GHz, -34.82 dB to -57.10 dB, 99.7 % to 99.8 % and 2208 kW/m<sup>2</sup> to 2800 kW/m<sup>2</sup> respectively after loading and incorporating artificial magnetic split-ring resonator-based metamaterial on the patch. Further improvement is also seen at other frequencies. The proposed design has immense benefits for humanity due to its improved capacity to manage larger connected IoT devices in the fields of Industrial 4.0, Healthcare 4.0, Autonomous Vehicles, Agriculture 4.0, Education, Climate Change, Sustainability, and Oceanography. [55]

### **11) Metamaterials and Their Application in the Performance Enhancement of Reconfigurable Antennas: A Review.**

In this review paper, a comprehensive review of metamaterial and its application in 5G and 6G communication systems is given. The application of metamaterials includes the enhancement of bandwidth and gain, size reduction, efficiency enhancement, reconfiguration of frequency and pattern, and intelligent reflecting surfaces and absorbers. For bandwidth, gain, and efficiency improvement, the metamaterials are loaded in the front or back of the reference antenna to obtain the desired improved results. In the aforementioned discussion, examples from the literature are given to show the workings and results of metamaterial-loaded antennas. For size reduction, the metamaterial is placed on the same plane as the antenna to obtain a miniaturized antenna with the same results as a larger antenna. Afterward, the reconfiguration application of metamaterial is discussed in terms of frequency reconfigurability and pattern configurability, along with various examples from the literature. Then, the current trend of metamaterial is discussed in terms of its applications in intelligent selective surfaces and absorbers. Researchers propose a number of studies, but only a few interesting articles are reported in this paper to serve as examples and evidence. [56]

### **12) A Novel Meander Line Metamaterial Absorber Operating at 24 GHz and 28 GHz for the 5G Applications.**

A metamaterial-based absorber operating at 24 GHz and 28 GHz frequency bands and allocated for 5G applications by the FCC was investigated here. The metamaterial structure consists of four meander lines connected with an I-shaped TL. The number of meander lines necessary to design the absorber at the proposed frequency bands was calculated using an analytical formulation, based on the phenomenon of total inductance produced by a meander line structure, under the matched-impedance conditions in the given electronic circuit at the operating frequencies. The meander line structure, created using this analytical formulae, was used to design the resultant structure and was then optimized and

simulated in CST to demonstrate the efficiency of the analytical model along with the performance of the absorber. A complete parametric analysis was carried out to demonstrate the design flexibility of the proposed absorber. To explore the practical employability and verify the simulated results of the absorber, a finite sheet of the proposed MA, with  $12 \times 12$  unit cells, was fabricated and tested in an anechoic chamber. In addition, the simulation results of the proposed MA for TE and TM polarizations at different angles of the MA were also verified by measurements, via the rotation of the fabricated prototype at different angles for both the TE- and TM-polarized wave. The performance comparison showed good agreement between simulated and measured results. It is concluded that the desired absorption band can be attained by suitably tailoring the absorber's constituents. Furthermore, these results validated that the proposed absorber would be useful for 5G communication applications, especially for the absorption of frequencies in 5G massive MIMO antenna arrays, to avoid the unwanted near-field interference. [57]

### **13) Polarization Stable Triband Thin Square-Shaped Metamaterial Absorber.**

An efficient triband metamaterial absorber is presented for X- and K-band applications. The unit cell is of simple shape. The absorber is fabricated on a thin polyamide, which makes it flexible. The parameters of the designed absorber are optimized. The simulated results show that it has good absorption rate and polarization stability. The stability is exhibited over a wide range in both TE and TE modes of the incident waves. The measured results are on par with the simulated results. The measurement is carried out with the waveguide measurement method. [58]

### **14) Double negative circular shaped inductively coupled metamaterial power splitter for the C-, X band applications.**

The metallic junction in the conductive layer on the dielectric medium for the suggested resonator with two complementary rings exhibits power diverges properties within the C-, X band region. The inductive coupling between two circular rings is observed with different rotational angles along the X- and Y-axis. High frequency based electromagnetic structural simulator CST is adopted for the characterization of the resonator, ADS software for the equivalent circuit validation, MATLAB. [59]

### **15) Design of Metamaterial Absorber for 5G Applications.**

In this paper, five resonant peak metamaterial absorber exhibiting more than 95% absorption has been proposed. The proposed metamaterial structure performs in the frequency range from S band to Ku band. The design consists of multiple geometries aligned together to form a symmetrical geometry. The structure is based on a lossy FR-4 substrate with the dimensions of  $10 \times 10 \times 1$  mm. The simulation is carried out using CST

Studio. The ultrathin, symmetrical and simple design makes the structure ideal for stealth, RCS, MIMO antenna for 5G applications. [60]

#### **16) A transparent and flexible microwave absorber covering the whole Wi-Fi waveband.**

The Wi-Fi technology has become a world-wide everyday service, and the accompanying electromagnetic pollution has attracted more and more attentions. This paper presents a transparent and flexible broadband metamaterial absorber (MMA) covering the whole Wi-Fi waveband. The transparent and conducting material Indium Tin Oxide (ITO) was used for both the frequency select surface and the backplane ground layer, and polydimethylsiloxane (PDMS) was used as the dielectric layer for the microwave MMA. The absorber featured >80% absorption covering a wide frequency range of (2.2-5.85) GHz, which includes all the frequency bands of Wi-Fi signal. The absorber was insensitive to the polarization angles and dropped little for incident angles less than 30°. Signal shielding experiments in 2.4 GHz and 5 GHz were carried out to demonstrate the application potential of the absorber. With additional advantages of optical transparency and mechanical flexibility, the broadband MMA can be useful in Wi-Fi related applications in the future. [61]

#### **17) Parabolic Split Ring Resonator (PSRR) based MNZ metamaterial with angular rotation for Wi-Fi/WiMAX/Wireless/ISM band applications.**

The engineering in artificial inclusions of metamaterials has immense potential to explore in the field of electromagnetic wave manipulation that created enormous opportunities in the design of millimeter or sub-millimeters structures. In this research paper, Parabolic Split Ring Resonator (PSRR) based MNZ (Mu-Near-Zero) metamaterial with a wider refractive index is introduced for Wi-Fi/WiMAX/Wireless/ISM band applications and printing on Rogers RT-5880 lossy substrate with a copper-based metallic structure at 5.8 GHz within the microwave frequency region. The resonant frequency, negative permittivity, near-zero permeability, and negative refractive index are between 5.5-6.3 GHz. This proposed metamaterial structure is analyzed with array structures, different substrate material, different orientations, and split gaps. [62]

#### **18) Broadband Millimeter wave Metamaterial Absorber Based on Embedding of Dual Resonators.**

Metamaterial based electromagnetic wave absorbers provide perfect absorption only over a narrow bandwidth. In this paper, broadband response is achieved through embedding of one resonator inside another in each unit cell of the metamaterial absorber lattice. These two resonators are oriented in the same direction to achieve reduced coupling between them realizing two absorption frequencies close to each other in order to broaden the effective bandwidth. Paper presents such an absorber at 77 GHz with a bandwidth of 8

GHz with the peak absorption of greater than 98%. The absorber is fabricated on 125  $\mu\text{m}$  thin and flexible polyimide substrate by patterning gold thin film in the shape of two split ring resonators as the metamaterial unit cell. The bandwidth is enhanced by more than a factor of two compared to what could be achieved from a metamaterial with single resonator structure. [63]

### **19) A compact tilted split ring multiband metamaterial absorber for energy harvesting applications.**

In this paper, a compact tilted split ring resonator metamaterial absorber operating at multiband frequency bands such as LTE2350, Wifi2450, and LTE2600 was designed. This work has introduced two additional split rings that are tilted at  $45^\circ$  at the center, which improves the bandwidth over the operating frequency bands. The proposed design shows that the absorber operates at the frequencies: 2.35 GHz, 2.45 GHz, and 2.6 GHz with a return loss of  $-15$  dB,  $-28$  dB, and  $-27$  dB respectively. [64]

### **20) Electrically Compact SRR-Loaded Metamaterial Inspired Quad Band Antenna for Bluetooth/Wi-Fi/WLAN/WiMAX System.**

In this paper, double negative metamaterial is used as the radiating patch of the antenna. The proposed metamaterial antenna shows the overall bandwidth of 200 MHz (from 2.40 to 2.60 GHz) and 390 MHz (from 3.40 to 3.79 GHz), respectively, for Bluetooth (2.40 to 2.485 GHz), Wi-Fi (2.4 GHz), WLAN (2.40 to 2.49 GHz and 3.65 to 3.69 GHz), and WiMAX (3.40 to 3.79 GHz) applications. The antenna's average gain is 1.50 dBi, with the maximum and minimum gains are 2.25 and 0.88 dBi, respectively. Parametric studies on different configurations of reported metamaterial antenna has been done for understanding the antenna's performance. Finally, time domain performances are analyzed by orienting the antenna as face to face, side by side X, and side by side Y directions, where the fidelity factors for antenna face to face, antenna side by side X and antenna side by side Y orientations are sequentially 0.86, 0.92 and 0.89. [65]

## **2.11 Summary**

This chapter presents an up-to-date and detailed review of existing microwave metamaterial absorbers and their designing methods from the literature. The elementary parameters for MM properties were discussed. Several metamaterials property types were reviewed, and existing MMAs' limitation was discussed. It was observed from the discussion that there are no techniques or formulas available till now to design perfect MMA with desired values of MM properties and absorptions at desired frequencies. The necessity of frequency-targeted MMA for practical applications was also discussed. Such engineered MMA has potential for the next generation of microwave communication systems.

## **Chapter 03**

### **Methodology and Design Process**

#### **3.1 Introduction**

A method is a systematic way to reach a goal. This phrase might refer to standard operating procedures in a specific industry or corporation, the methods utilized in a specific research project, or the manner by which a specific operation was done. People may sometimes refer to the investigation of such procedures as "methodology" instead of the techniques themselves.

Methodology can be thought of as a group of different techniques, each of which is used on different parts of the whole range of methodology. Qualitative research and quantitative research are the two parts that make up research.

#### **3.2 Research Design**

The entire plan created to address the study's research questions is referred to as the research design. The design of the research project outlines the study resources, including the research topic, dependent and independent variables, experimental design, and, if applicable, data collection methodologies and a statistical analysis plan. Methodology of this study:

- Study about Metamaterial Absorber.
- Study on properties of Metamaterial Absorber.
- Study the procedures of Metamaterial Absorber design.
- Learn how to use CST software tools for this design.
- Calculate necessary parameters to design metamaterial absorber.
- To find out some application of this work.

#### **3.3 Analysis Method**

Initially, the design technique of perfect MMA is briefly discussed. The design specification of perfect MMA is discussed in the first section. The unit cell design for polarization insensitivity is discussed with three different structures.

Secondly, the design technique for frequency-targeted and co-polarization insensitive MMA are discussed with three different structures for three different applications. The finite difference time domain-based CST microwave studio was utilized to simulate the absorbers considered. Next, the equivalent circuit design technique for these absorbers is discussed with necessary equations.

### 3.3.1 Research Methodology Design

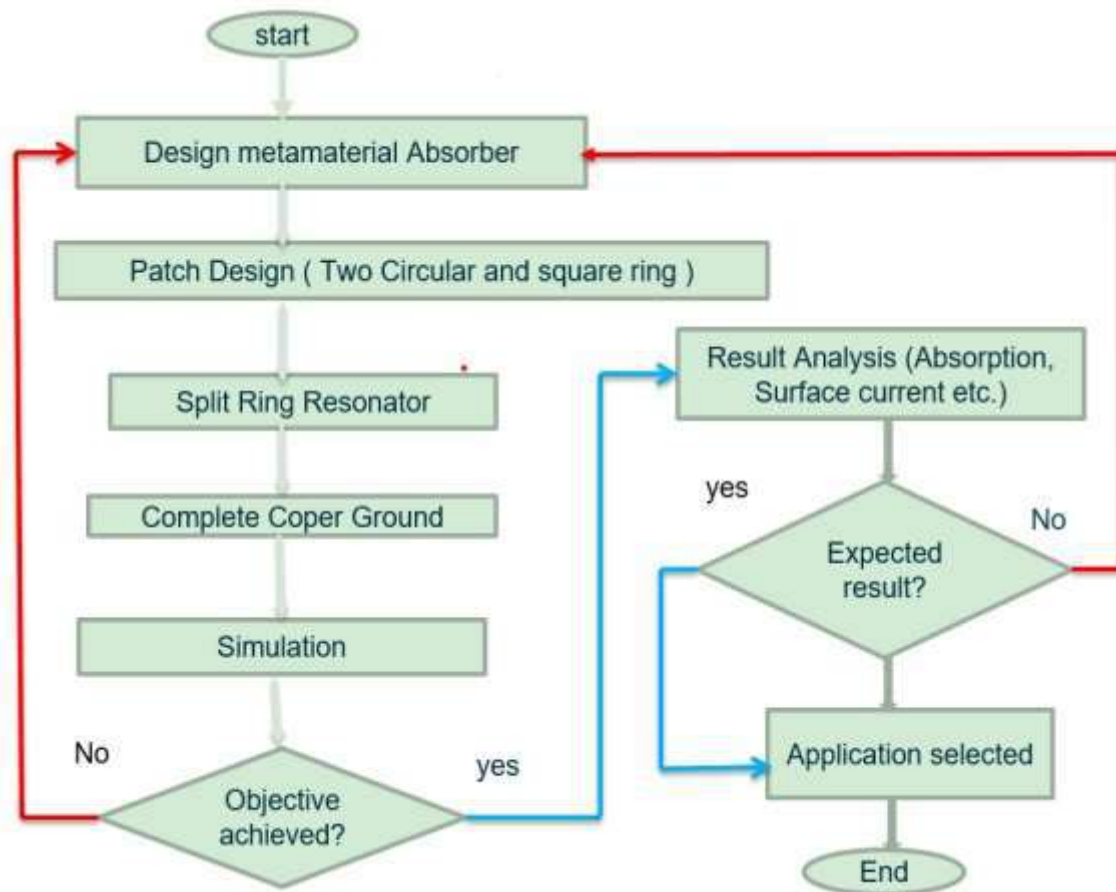

Figure 3.1: Flowchart for Metamaterial Absorber develop

**Step1:** Design Metamaterial Absorber.

**Step2:** Design Two square and circular split ring resonator use FR-4 Substrate and metamaterial Dimension is 20\*20mm<sup>2</sup>.

**Step3:** Simulation the design.

**Step4:** Result analysis like that Absorption, permittivity, permeability, surface current etc. Achieve DNG or SNG metamaterial absorber design for near perfect absorption.

**Step5:** Application Selection.

**Step6:** Conclusion and recommendation.

### 3.4 Metamaterial Absorber Design

The metamaterial structure was designed using a couple of split ring resonators and a couple of split square ring resonators. The resonating layer was designed using copper with the dielectric constant of  $5.8e+007s/m$ . FR-4 Dielectric material was used to design the Substrate layer. Fig. 1 shows the structure of the MMA unit cell. The back layer of the MMA was also using copper to prevent the propagating wave from transmitting through the MMA structure.

To design the metamaterial, we use 3D co-ordination system in CST microwave studio simulation tool

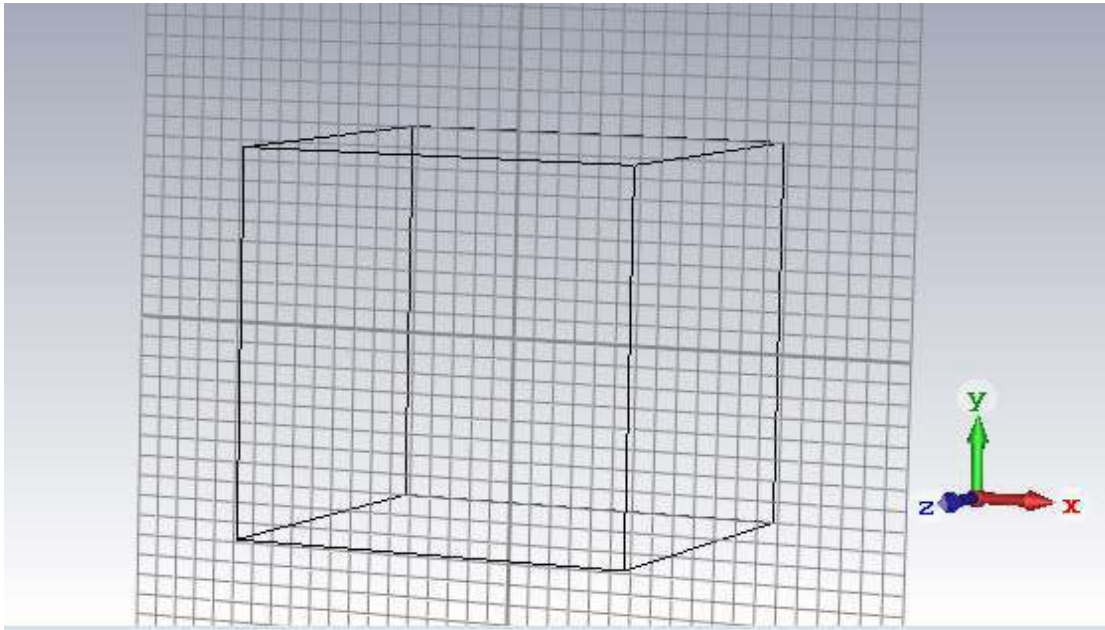

Figure 3.2: 3D co-ordination view in CST software

The patch also uses copper. The thickness of the FR-4 is 1.6mm and the Thickness of the copper is 0.035mm. All the geometrical parameters are listed in TABLE. The MMA unit cell is modelled and simulated using the commercial full-wave simulation software CST STUDIO SUITE.

#### 3.4.1 Substrate

The width of the substrate is 20mm and length of the substrate is also 20mm. The thickness of the substrate is 1.6mm for this design, we have used here FR-4 (loss free) substrate material.

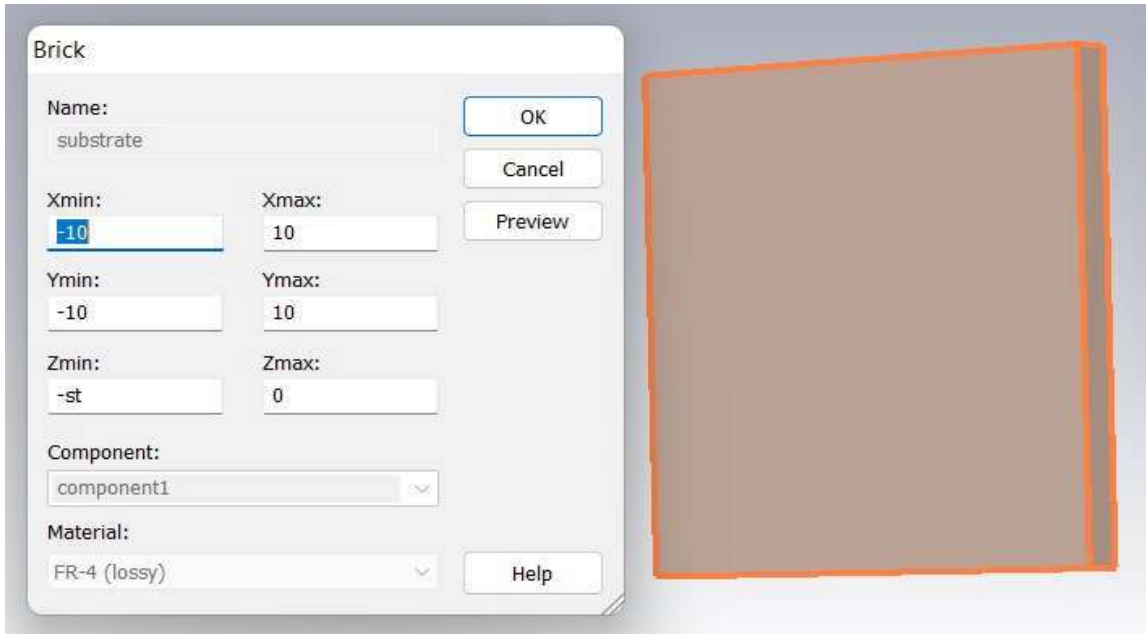
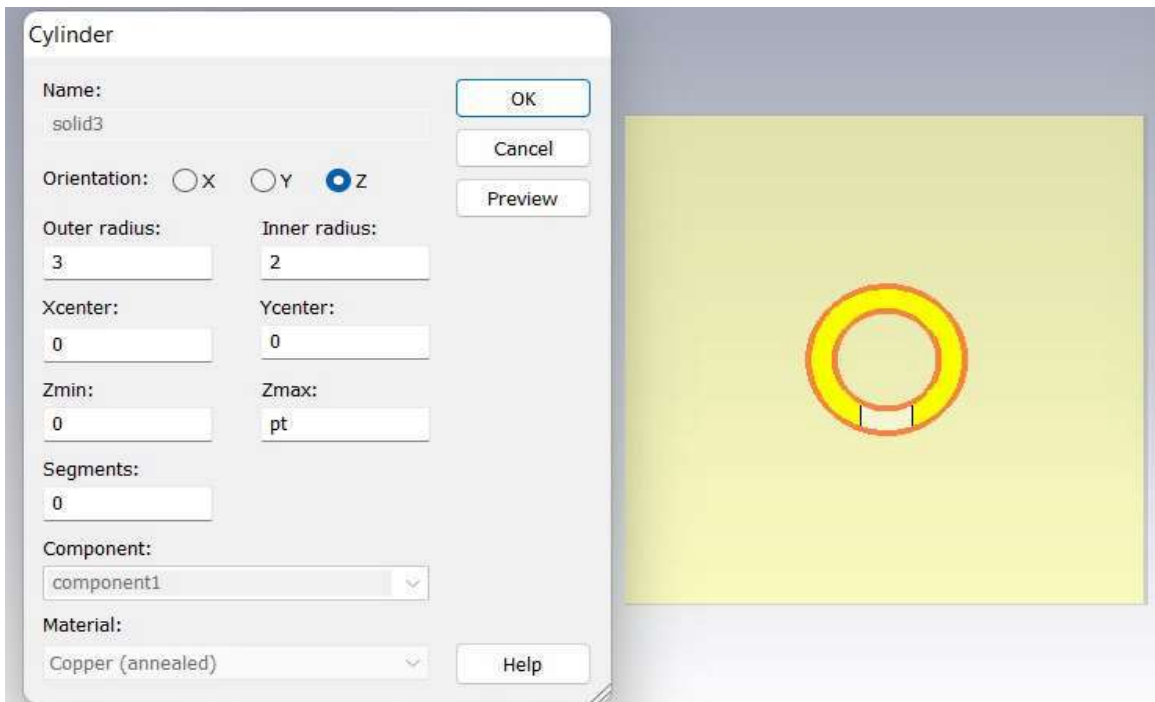

Figure 3.3: Substrate

### 3.4.2 Patch Design (Step 1)

At first, design a split ring resonator. Here we show the specifications by those figures



(a)

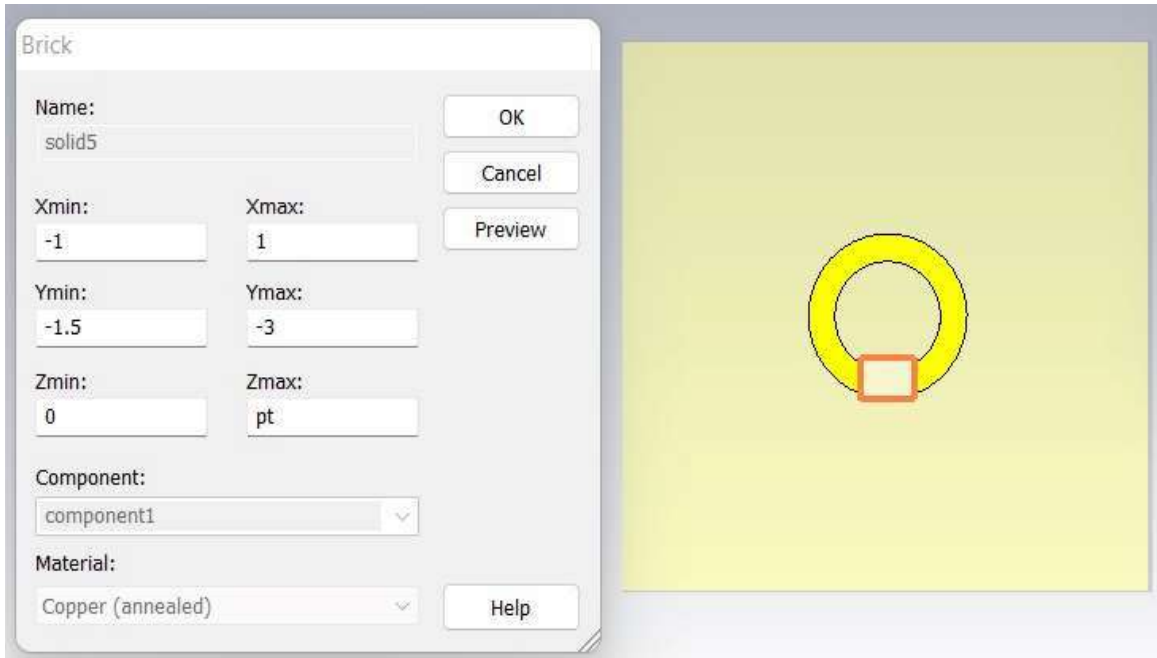

(b)

Figure 3.4: (a) circular ring resonator (b) subtract

### 3.4.3 Patch Design (Step 2)

Design another split ring resonator. Here we show the design process by those figures

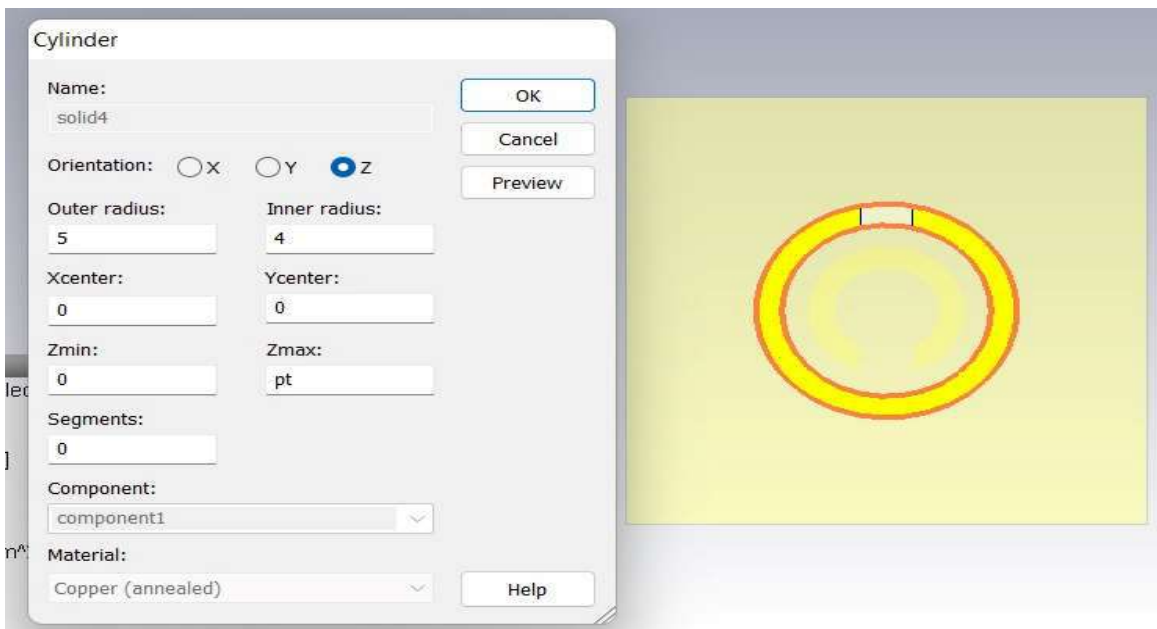

(c)

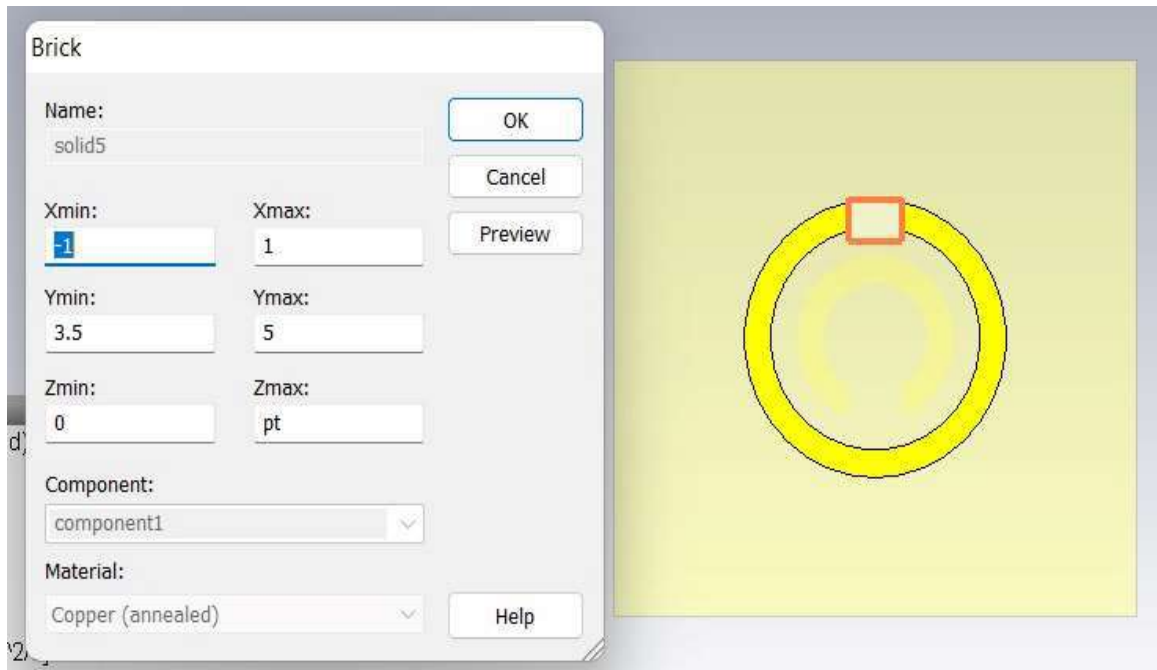

(d)

Figure 3.5: (c) circular ring resonator, & (d) Subtract

### 3.4.4 Patch Design (Step 3)

Then design a split square ring resonator. Here we show the design process by those figures

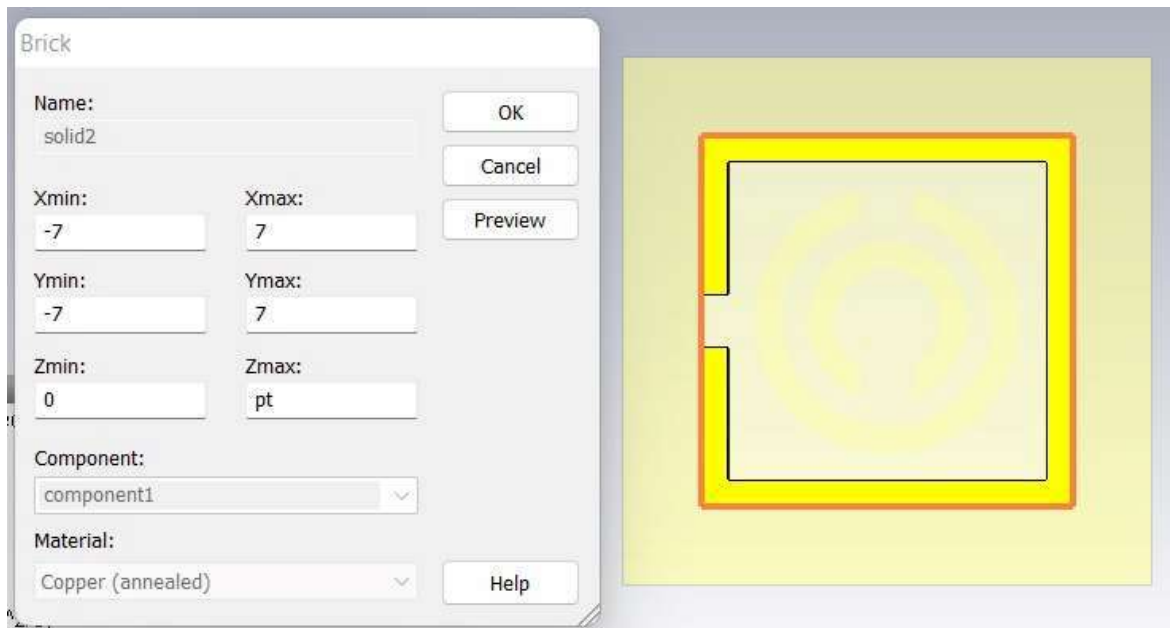

(e)

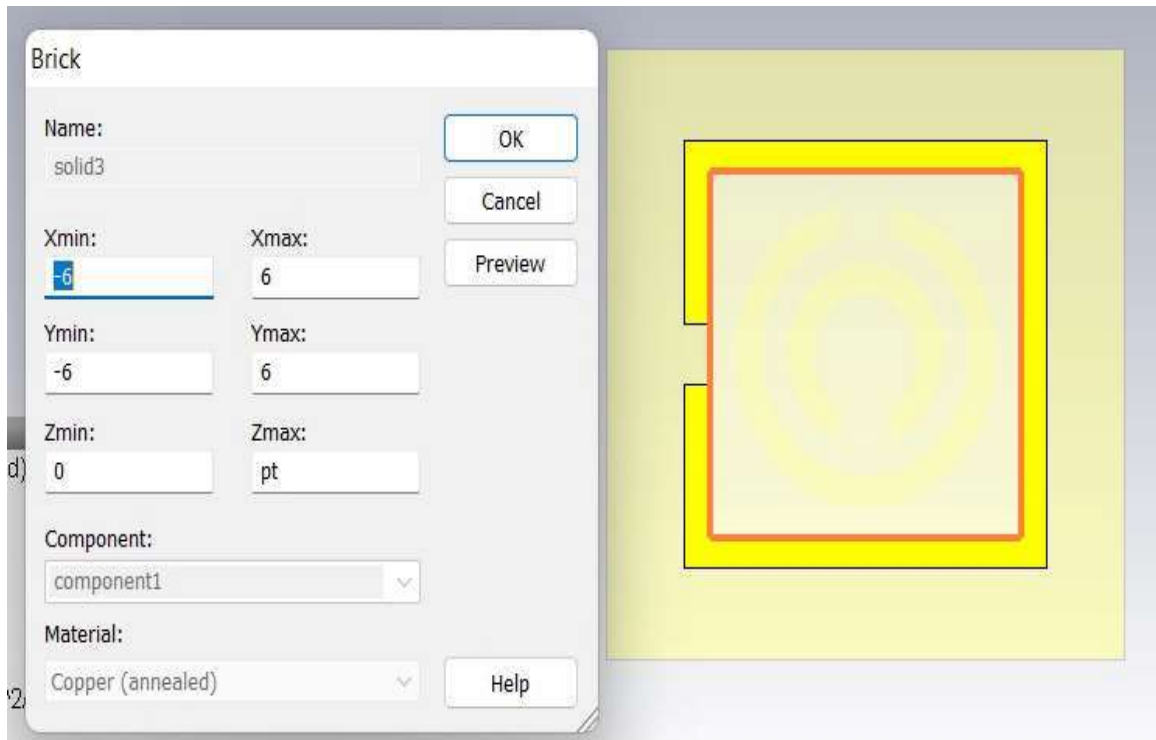

(f)

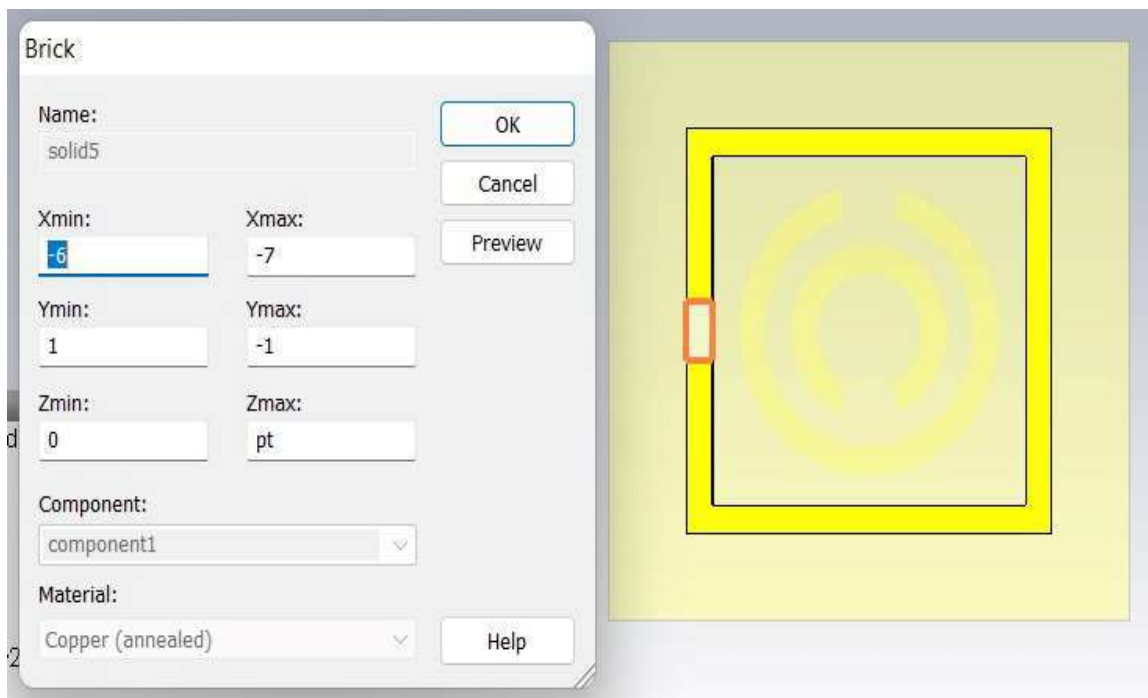

(g)

Figure 3.6: (e) & (f) square ring resonator, (g) Subtract

### 3.4.5 Patch Design (Step 4)

Design another split square ring resonator. Here we show the design process by those figures

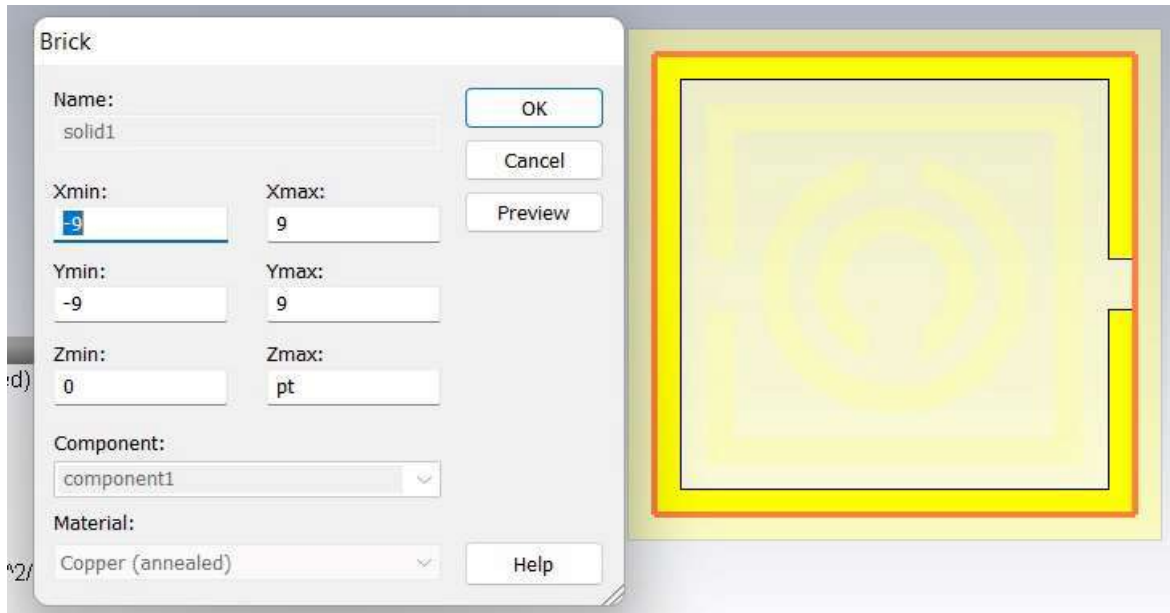

(h)

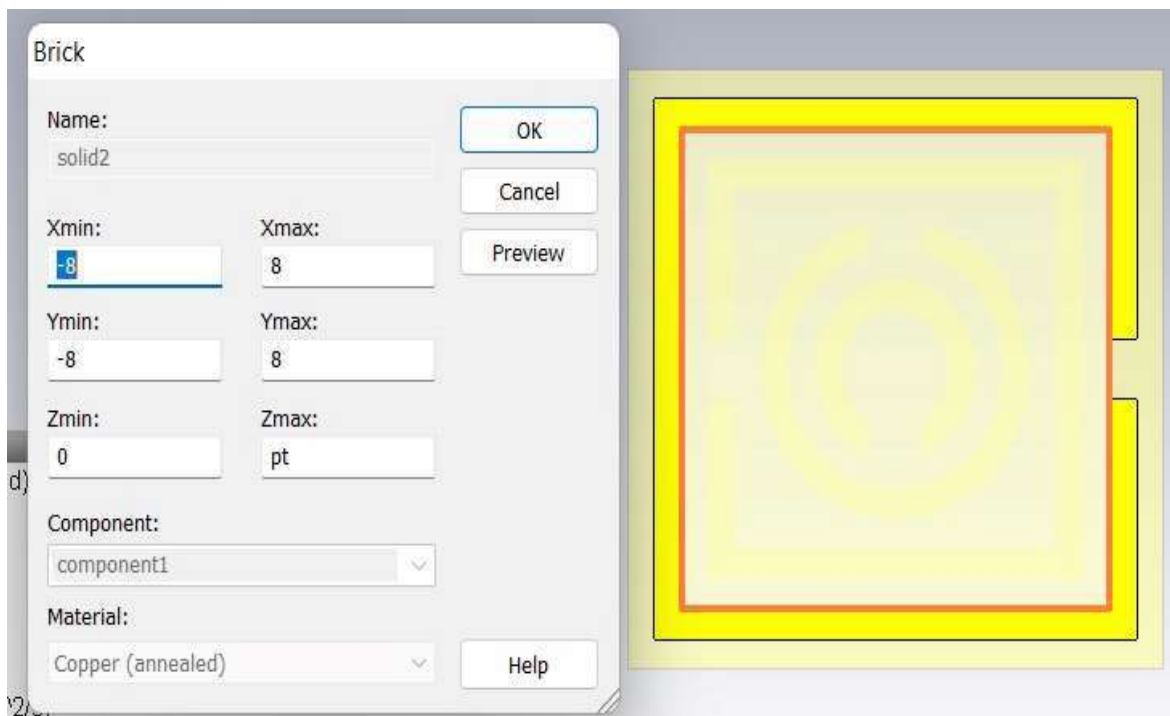

(i)

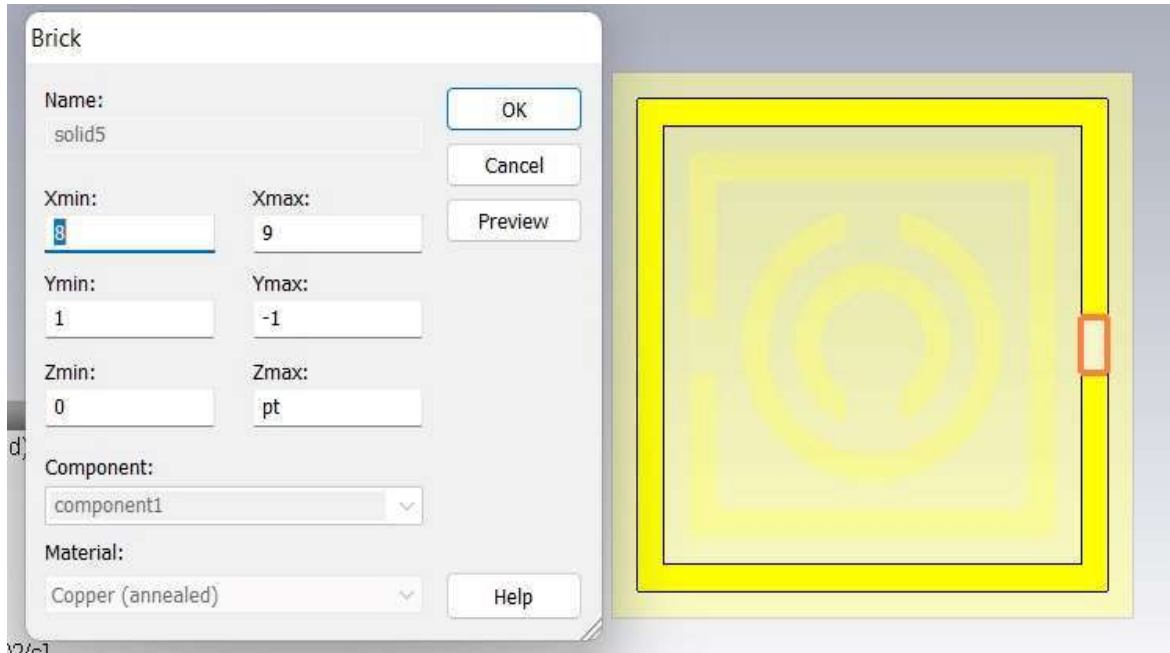

(j)

Figure 3.7: (h) & (i) square ring resonator, (j) Subtract

### 3.4.6 Final Patch view or (Final Design)

Here, in fig. 3.8, we show that the final view of Metamaterial Absorber also we add

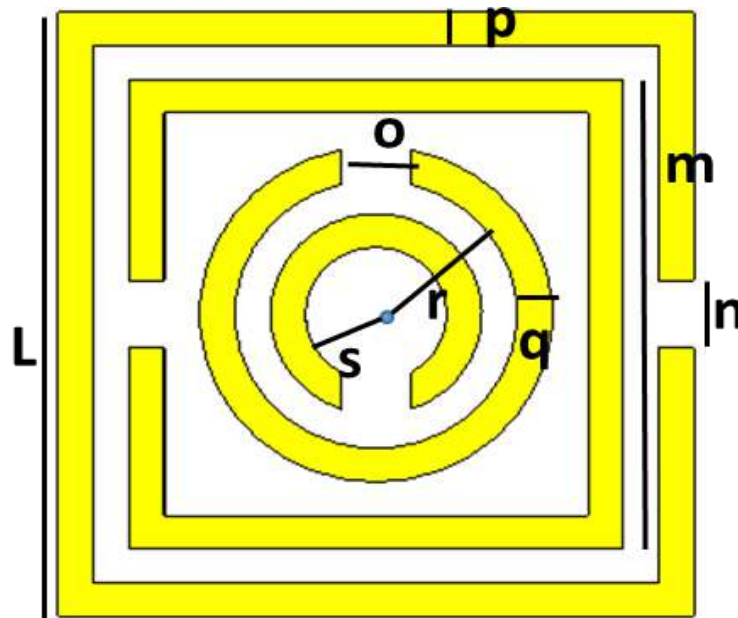

Figure 3.8: Final Design

**Table 3.1 Parameter of the MMA structure**

Parameter	Size(mm)	Parameter	Size(mm)
<b>L</b>	18	<b>p</b>	1
<b>m</b>	14	<b>q</b>	1
<b>n</b>	2	<b>r</b>	4
<b>o</b>	2	<b>s</b>	2

### 3.4.7 Add waveguide port

Waveguide port selection is important for simulation. Here we use two waveguide port, one port negative and another port is positive. It has to be flowed from one side of metamaterial to another side.

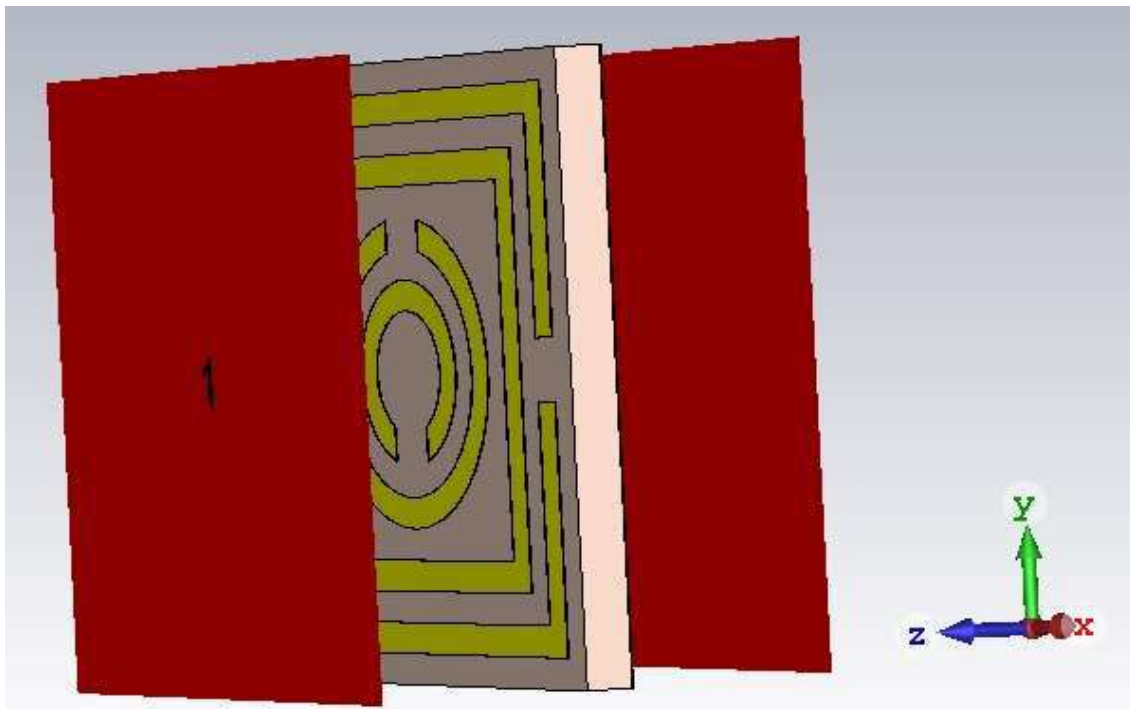

Figure 3.9: After apply waveguide port

### 3.4.8 Unit cell design

Unit cell design for a metamaterial absorber involves tailoring the geometry, material composition, and arrangement of unit cells to achieve desired absorption characteristics in a specific frequency range. Metamaterial absorbers are engineered structures capable of selectively absorbing electromagnetic waves, typically in the microwave, terahertz, or optical frequency ranges.

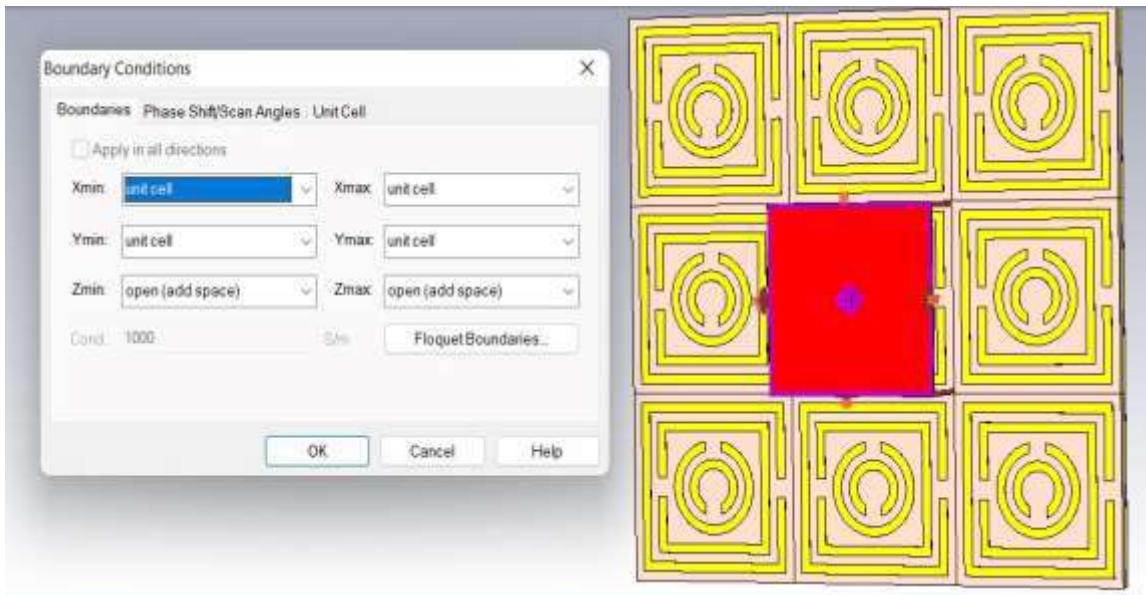

Figure 3.10: Unit cell design

## Chapter 04

### Simulation and Result Analysis

#### 4.1 Introduction

Metamaterials Absorber (MMA) is a type of artificial material that can manipulate electromagnetic waves and exhibit unique electromagnetic properties that are not found in naturally occurring materials. Metamaterials are artificially engineered structures made up of periodic arrays of subwavelength building blocks. These materials have been extensively studied in recent years due to their potential applications in various fields such as sensing, imaging, communication, and energy harvesting. The properties of metamaterials are defined by their effective permittivity and permeability, which are different from those of natural materials.

The concept of metamaterials was first introduced by Veselago in 1968, and since then, the research on metamaterials has evolved rapidly. In recent years, multiband metamaterial absorbers have been proposed and studied extensively due to their potential applications in multiband sensing and imaging [66]. In recent years, multiband metamaterial absorbers have gained considerable attention due to their ability to absorb a wide range of frequencies. We propose the design of a multiband absorber (MMA) based Square Split Enclosed Labyrinth Maze Shaped Metamaterial Absorber Structured. The multi-layer metamaterial structure is designed to be used in the frequency bands such as Sensing applications.

We get the multiband (2.44GHz, 3.5GHz, 12.039 GHz, 15.516 GHz & 16.713 GHz) resonance frequencies. Also this MMA has been designed for a wide range of frequencies from microwave (C, X, Ku, K) to terahertz [66], with Ku and K band frequencies finding significant applications in radar, telecommunications, and sensing fields[67]. However, there is still room for improvement in terms of bandwidth, absorption efficiency, and tuning capability. Therefore, there is a need for further research to optimize the design and performance of multiband metamaterial absorbers. Apart from electromagnetic wave absorption, metamaterials have also been explored for sensing applications [68].

#### 4.2 MMA Result Analysis

The designed absorber has shown metamaterial absorber properties at the resonance frequency (2.44GHz, 3.5GHz, 12.039 GHz, 15.516 GHz & 16.713 GHz) which is shown in the Fig. 1. To get the appropriate inductance for the patch, along with the needed resistance and the related capacitance for the resonance frequency, the centre parallel strips were essential.

### 4.2.1 Reflection Co-efficient

The designed absorber has shown required metamaterial absorber properties at the resonance frequency (2.44GHz, 3.57GHz, 12.077GHz, 15.535GHz, and 16.778GHz). The central parallel strips were required to tune the resonance frequency at S band & KU band, i.e., to get the required inductance of the patch along with the necessary resistance and the associated capacitance for the resonance frequency.

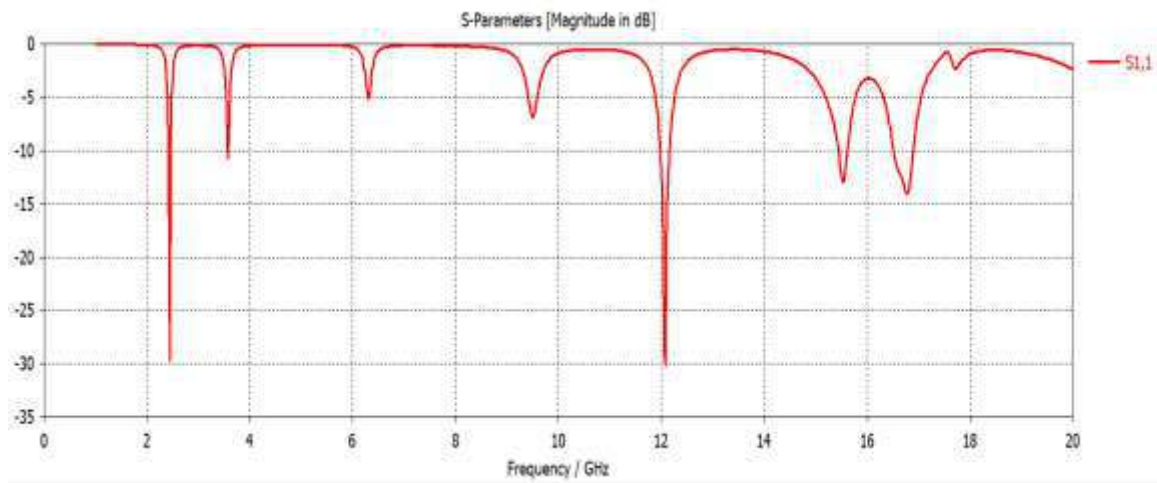

Figure 4.1: Reflection Co-efficient

### 4.2.2 Reflectance

In fig. 4.2, Here we see that no reflectance in desired resonance frequency.

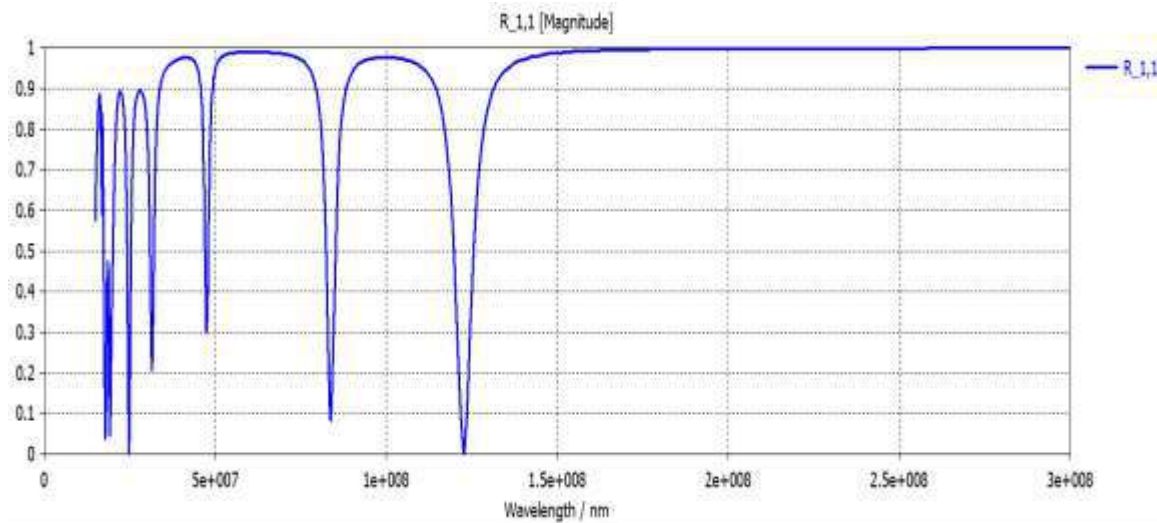

Figure 4.2: Reflectance

### 4.2.3 Transmission

In fig. 4.3, show that the transmission result. Here we see that no transmission in desired resonance frequency.

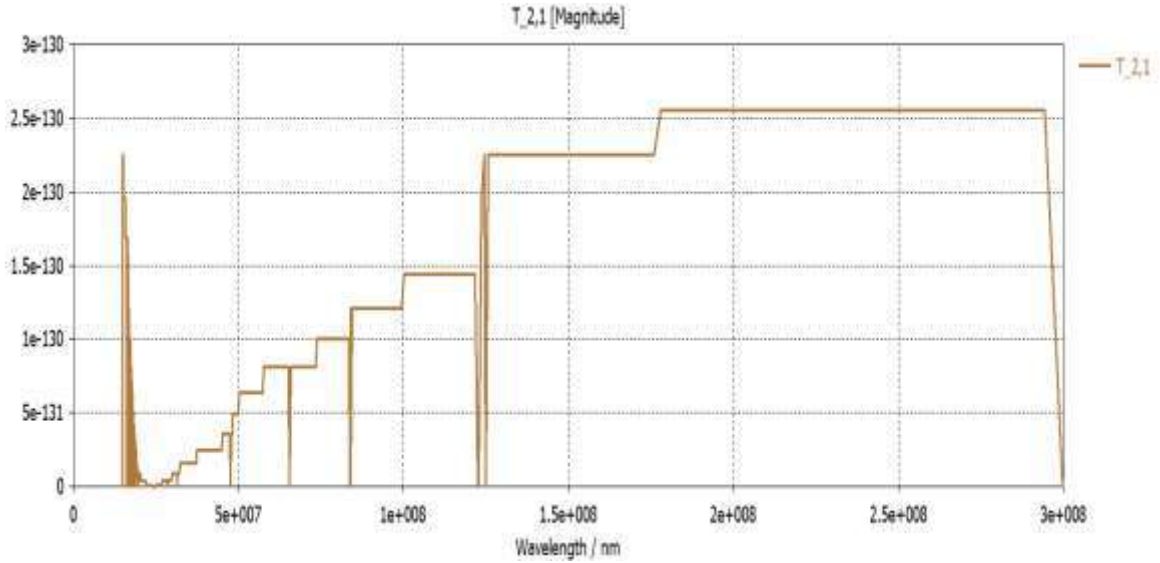

Figure 4.3: Transmission

### 4.2.4 Absorption

Fig. 4 shows the absorption behaviour of the proposed MMA for different Frequency Square Split Enclosed Labyrinth Maze Shaped structure. The peak resonance in simulated and measured results are 2.44GHz, 3.5GHz, 12.039 GHz, 15.516 GHz & 16.713 GHz frequencies.

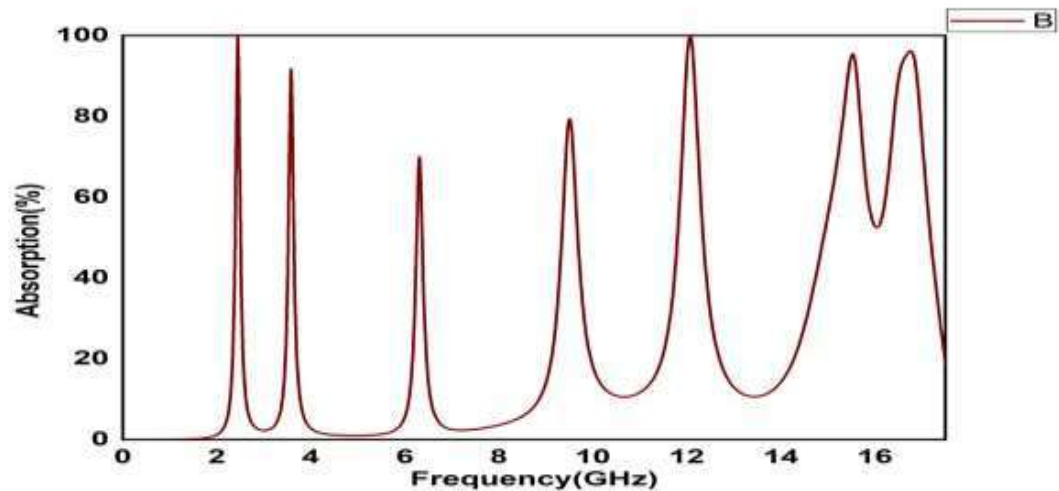

Figure 4.4: Absorption

#### 4.2.5 Absorption, Reflection & Transmission

In fig-4.5 show that the absorption, reflectance and transmission result. We see, No Reflectance & Transmission at desired resonance frequency because we use complete copper Ground.

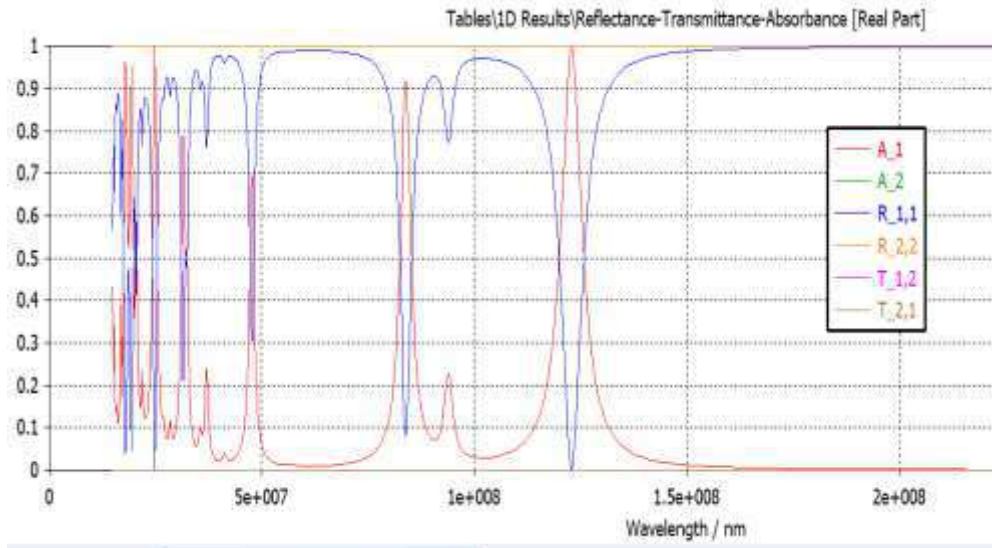

Figure 4.5: Absorption, Reflection & Transmission

#### 4.2.6 Permittivity

Figure 6, shows the permittivity for different resonance frequency (2.44 GHz, 3.57 GHz, 12.039 GHz, 15.516 GHz, and 16.713 GHz). We see that permittivity value is negative.

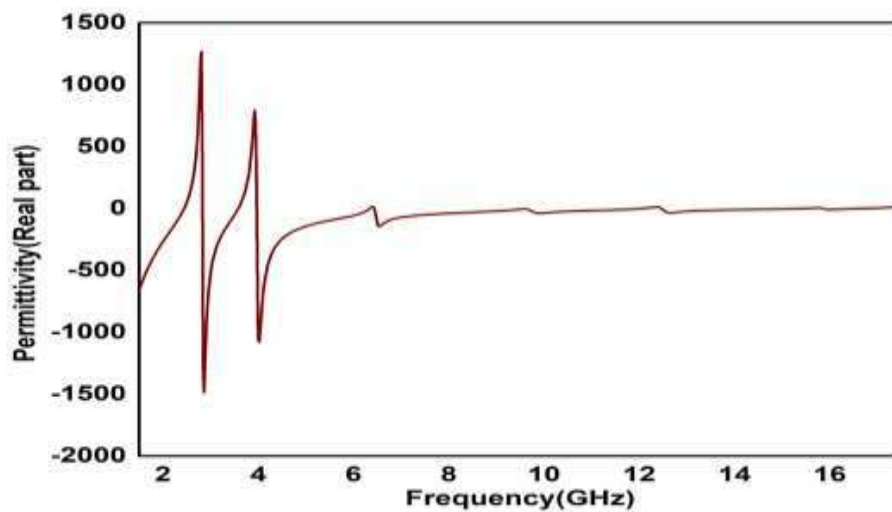

Figure 4.6: Permittivity ( $\epsilon$ )

### 4.2.7 Permeability

Figure 7, shows the permeability for different resonance frequency (2.44 GHz, 3.57 GHz, 12.039 GHz, 15.516 GHz, and 16.713 GHz). We see that permeability value is positive.

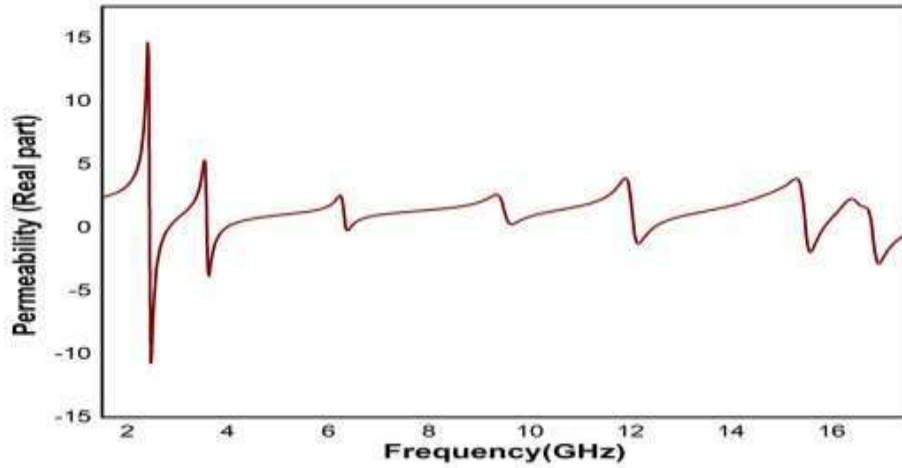

Figure 4.7: Permeability ( $\mu$ )

### 4.2.8 Refractive Index

In fig. 4.8, show the refractive index result. Here the refractive index value is Zero.

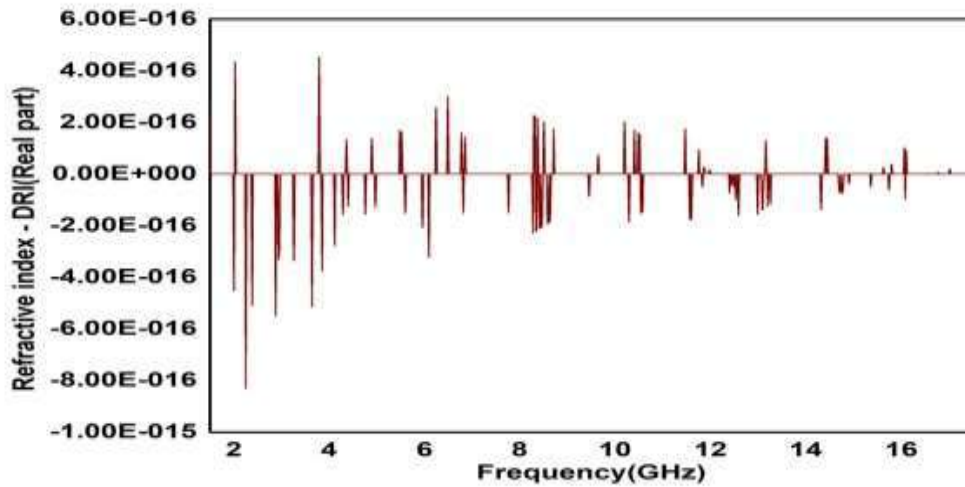

Figure 4.8: Refractive Index

Figure 4.6, 4.7 & 4.8, shows the permittivity, permeability and refractive index plot for different resonance frequency (2.44GHz, 3.5GHz, 12.039 GHz, 15.516 GHz & 16.713

GHz). We see that permittivity value is negative and permeability value is positive. So we called this absorber is single negative material (SNG). Also we see the refractive Index value is zero at desired resonance frequency.

**TABLE 4.1 METAMATERIAL ABSORBER PROPERTIES FOR THE PROPOSED ABSORBER**

<b>Resonance Frequencies (GHz)</b>	<b>Relative permittivity (<math>\epsilon</math>)</b>	<b>Relative permeability (<math>\mu</math>)</b>	<b>Refractive Index</b>	<b>Absorption (%)</b>
2.44 GHz	-3.01864	3.51406	0	99.4%
3.57 GHz	-4.19364	1.32683	0	91.65%
12.039 GHz	-0.91428	1.09469	0	98.75%
15.516 GHz	0.52455	-1.13165	0	95.37%
16.713 GHz	-1.03859	1.52446	0	95.77%

#### **4.2.9 Unit cell $S_{11}$ result**

Unit cell design is a crucial aspect of metamaterial absorbers. It involves choosing the geometry, materials, and resonant behavior of the repeating pattern within the absorber. The design aims to maximize absorption efficiency. In fig- 4.9, we see that unit cell design  $S_{11}$  result for desired resonance frequency

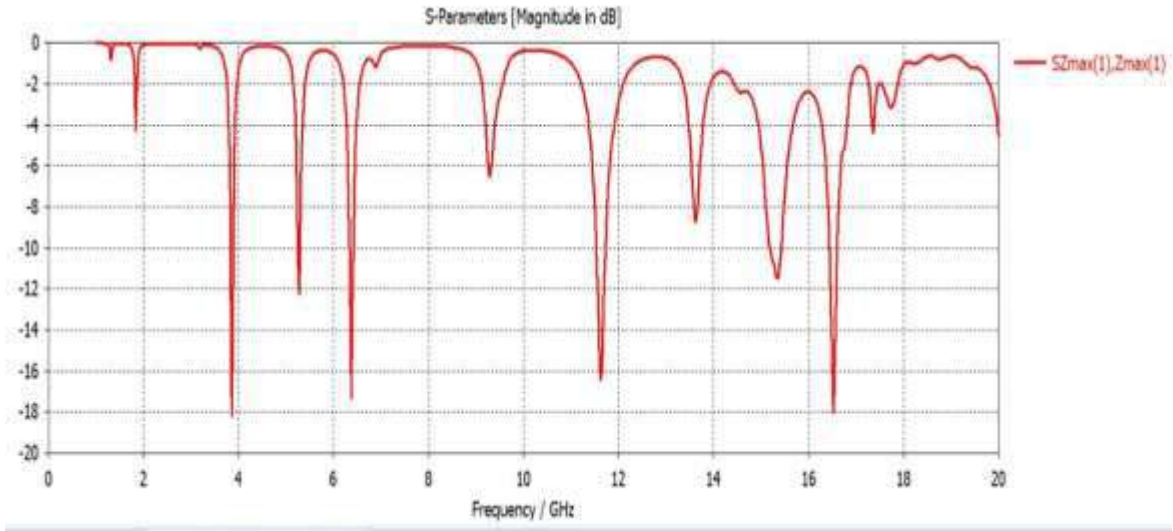
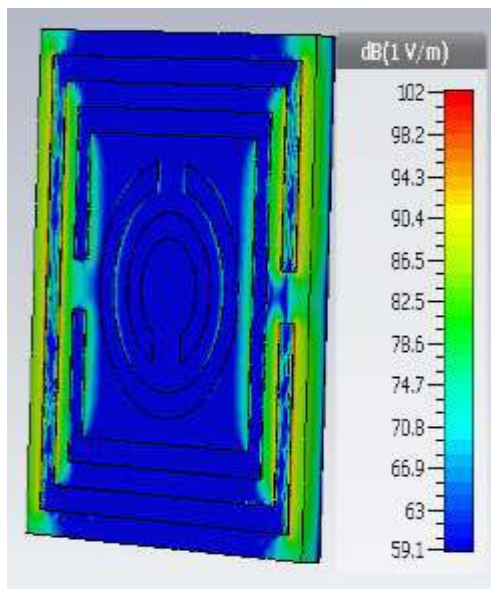

Figure 4.9: Unit cell  $S_{11}$  result

#### 4.2.10 MMA E-field

In metamaterial absorbers, electric fields (E-fields) are involved in the absorption of electromagnetic waves. They induce currents and oscillations in the absorber structure, converting the energy into heat or other forms. E-fields can be enhanced and controlled within the absorber to achieve efficient absorption and frequency selectivity. Manipulating the E-field distribution allows customization of absorption characteristics. Metamaterial absorbers utilize E-fields to efficiently absorb specific wavelengths or frequencies of electromagnetic waves.



(a) 2.44 GHz

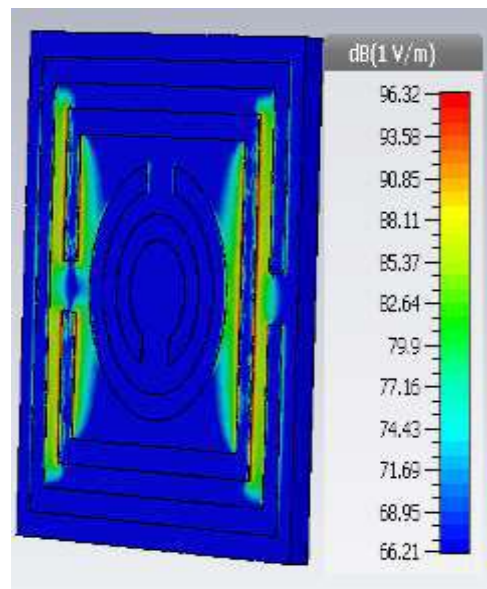

(b) 3.5 GHz

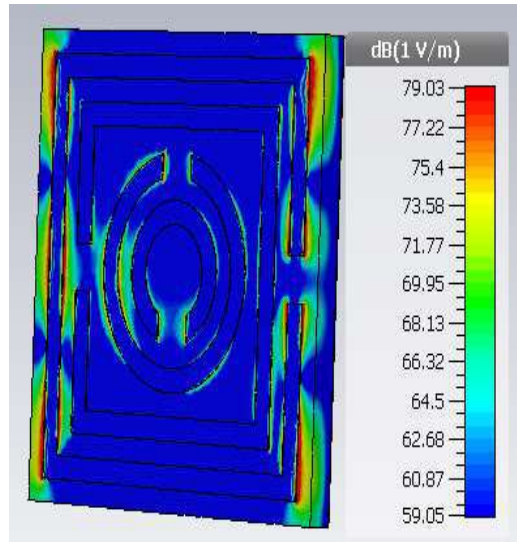

(c) 12.039 GHz

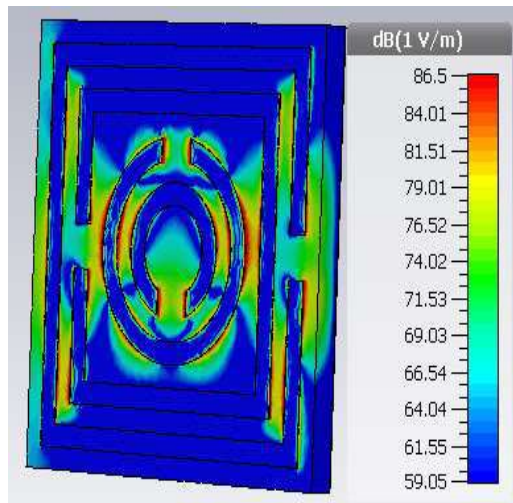

(d) 15.516GHz

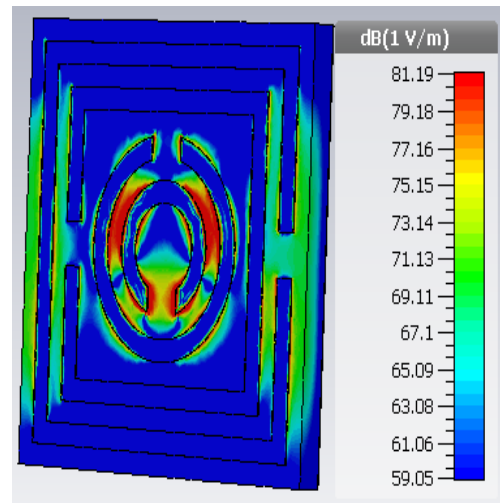

(e) 16.713 GHz

Figure 4.10: (a), (b), (c), (d) & (e) E-field for respectively 2.44 GHz, 3.5GHz, 12.039GHz, 15.516GHz, and 16.713 GHz

#### 4.2.11 MMA H-field

Metamaterial absorbers involve the interaction of both electric fields (E-fields) and magnetic fields (H-fields) in the absorption process. The E-fields and H-fields are coupled and influence each other within the metamaterial structure. The specific behavior and distribution of the H-field within a metamaterial absorber can vary depending on the design and composition of the absorber structure, including its resonant properties and geometry.

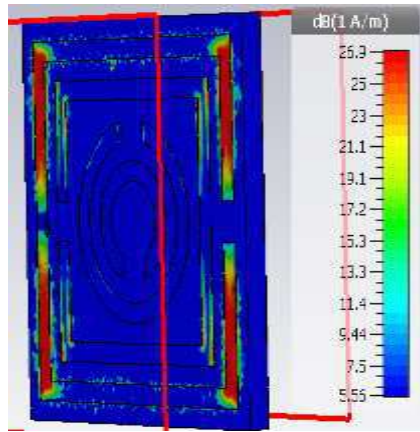

(f) 2.44 GHz

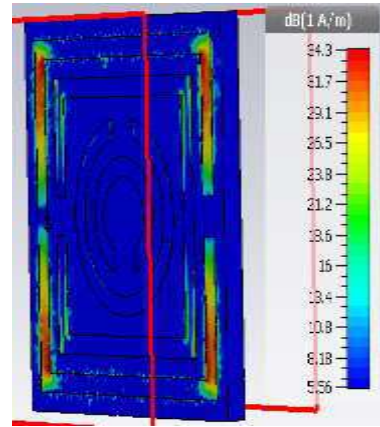

(g) 3.5 GHz

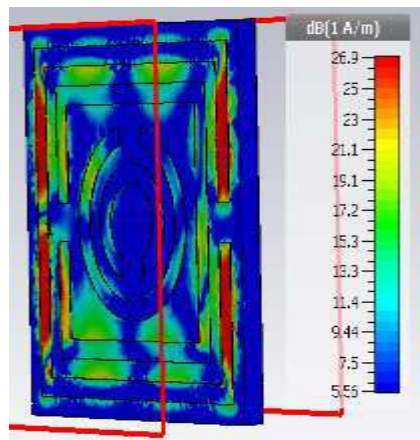

(h) 12.039 GHz

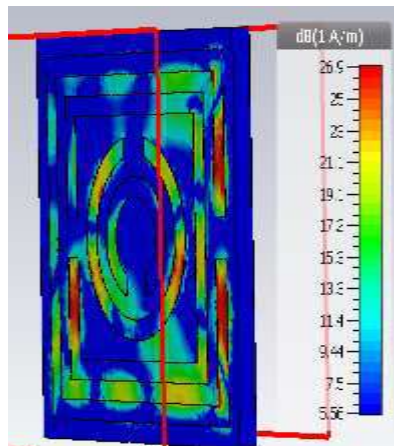

(i) 15.516 GHz

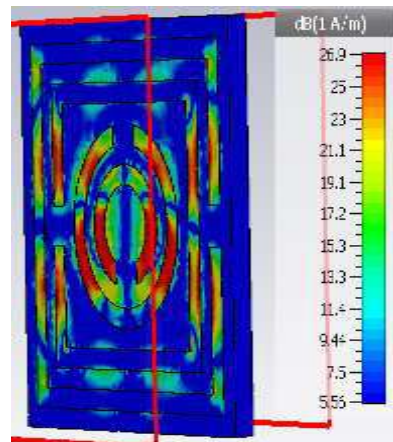

(j) 16.713 GHz

Figure 4.11: (f), (g), (h), (i) & (j) h-field for respectively 2.44 GHz, 3.5GHz, 12.059GHz, 15.516 GHz, 16.713 GHz

#### 4.2.12 Surface Current

Surface currents in metamaterial absorbers are induced by incident electromagnetic waves and play a crucial role in absorption. They flow along the surface of the absorber structure and contribute to efficient absorption by interacting with the incident electric fields. Controlling the geometry and resonant properties of the metamaterial allows customization of the distribution and magnitude of surface currents.

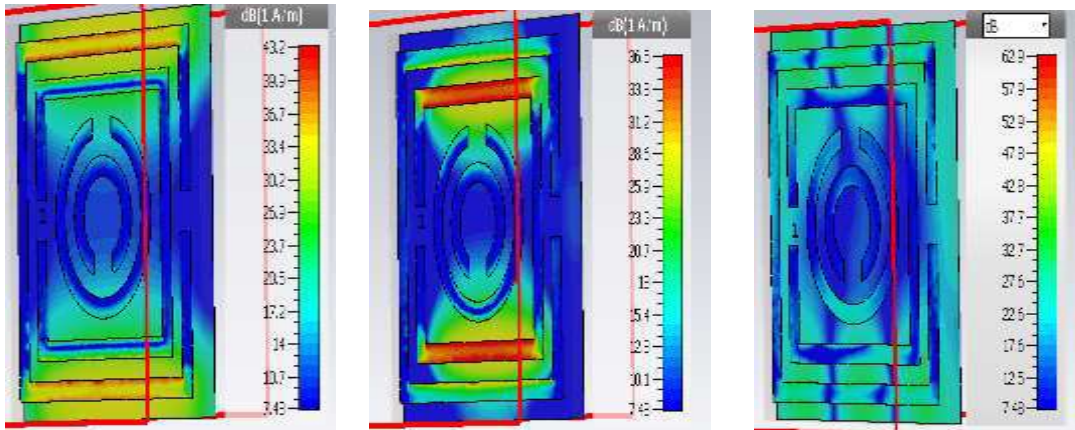

(k) 2.44 GHz

(l) 3.5 GHz

(m) 12.039 GHz

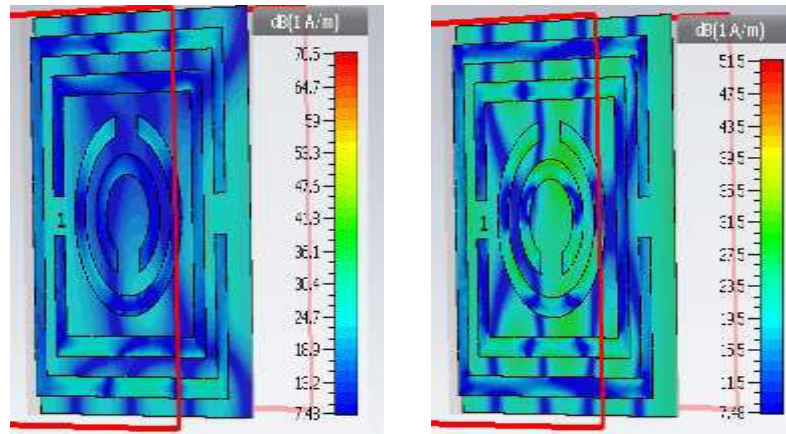

(n) 15.516 GHz

(o) 16.713 GHz

Figure 4.12: (k), (l), (m), (n) & (o) surface-current for respectively 2.44 GHz, 3.5GHz, 12.059GHZ, 15.516 GHz, and 16.713 GHz

Fig. 4.10, Fig. 4.11 and Fig. 4.12 shows the planned MMA's e-field, h-field, and surface current distribution are shown in figure. It can be comprehended via analysis. The h-field is seen to be significantly more agitated than the e-field. The red hue denotes a higher density of surface current, e-field, and h-field.

### 4.3 Hydrocarbon Sensing Application

The proposed MMA can be a sensor to distinguish different hydrocarbon materials. The complicated relative permittivity and permeability value establish the suggested MMA's sensing qualities. One way of changing MMA characteristics is by varying the dielectric property. The two most common approaches to using an MMA as a sensor are introducing a layer of test object on top of the MMA patch or sandwiching a layer between the patch substrate and substrate ground.

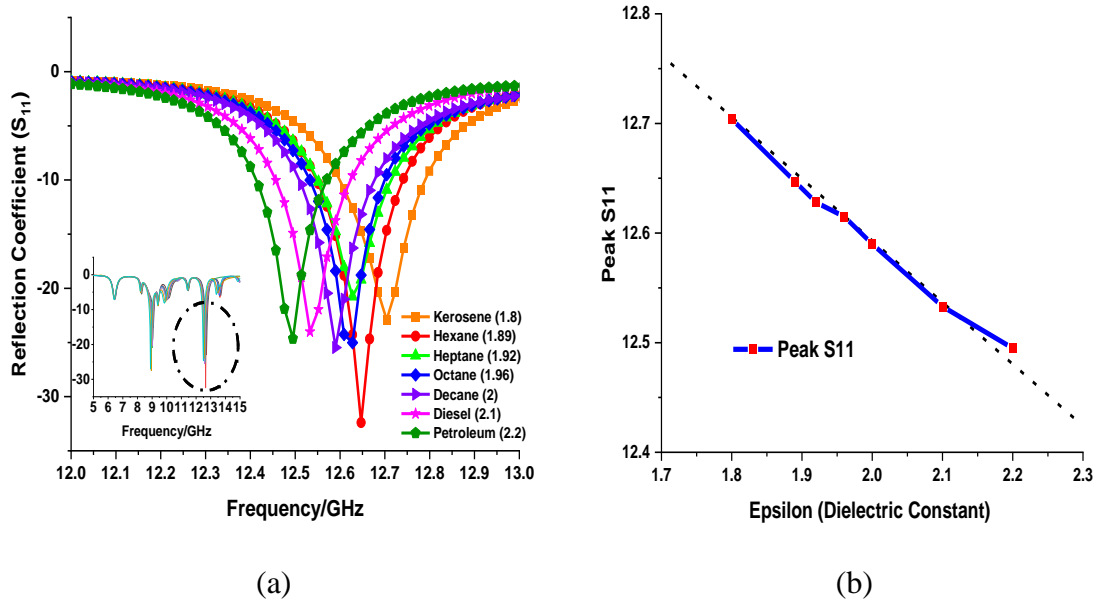

Figure 4.13: (a)  $S_{11}$  response of the MMA for different hydrocarbon materials, (b) Peak reflection band response with respect to the dielectric constant of testing materials.

TABLE 4.2: HADROCARBON SENSING

Hydrocarbon materials	Dielectric constant	Peak $S_{11}$ response (GHz)	Peak $S_{11}$ shift (GHz)	$S$
Kerosene	1.8	12.704	1.424	1.8
Hexane	1.89	12.647	1.367	1.5
Heptane	1.92	12.62792	1.34792	1.5
Octane	1.96	12.615	1.335	1.4
Decane	2.0	12.59	1.31	1.3
Diesel	2.1	12.533	1.253	1.1
Petroleum	2.2	12.495	1.215	1.0

This paper proposes a permittivity sensing model employing the suggested MMA for sandwich-based sensing of various hydrocarbon materials the reflect proposed MMA on a band ( $S_{11}$ ) of the captive to different hydrocarbons. Seven hydrocarbons with their dielectric properties have been given in the TABLE 4.2, which has been used in this

experiment. Other hydrocarbons with their dielectric constant were placed between the patch substrate and substrate ground of the MMA as a tasting object. The test object layer changes affecting the medium's impedance, leading to a shift in the reflection band. Fig. 4.13 (a) shows the  $S_{11}$  response of the MMA for different hydrocarbon materials. As the dielectric constant increases of the tasting layer, the MMA reflection band shifts toward lower frequency ranges. The reflection band shifts linearly. Fig. 4.13 (b) shows the peak reflection band response for the dielectric constant of testing materials. The Peak reflection band shift (GHz) was compared with the Peak reflection band when no tasting materials were introduced. When no tasting materials were presented, The MMA sensor setup had a peak reflection band at 11.28 GHz. The lowest band shift is 0.01 GHz between Heptane and Octane. As is seen from the figure, the peak reflection band responds from almost a straight line.

Sensitivity is the ratio of Change in resonant frequency with the difference in the dielectric constant of the encompassing medium. The extracted sensitivities  $S$  is defined in Equation 1 here  $\Delta f$  is the Change of frequency and  $\Delta n$  is the Change between the initial frequency ( $f_i$ ) when no test object was used and the frequency ( $f_t$ ) when the test object was used.  $\Delta n$  was the Change between the initial permittivity of medium ( $n_i$ ) when no tested object was used and the permittivity of medium ( $n_t$ ) when the test object was used. [24]  $n_i$  is 1, as initially, the medium was the air with the primitive value of 1. From this equation, it has been calculated that the average sensitivity of the MMA is 1.4GHz/ $\epsilon$  for different Hydrocarbon materials

$$S = \frac{\Delta f}{\Delta n} = \frac{f_i - f_t}{n_t - n_i} = \frac{f_i - f_t}{n_t - 1} \quad (4.1)$$

**TABLE 4.3 COMPARISON TABLE**

Ref.	Publication year	Material and thickness of substrate	Dimension of MMA	Type of Antenna used	Metamaterial property with absorption frequency	SAR Reduce (%)	Application
[56]	2019	FR4 1.574mm	40 mm × 32mm	Monopole Antenna.	2.45 GHz	0.15W/kg	WBAN applications

[57]	2020	Rogers RO3003	30 × 30 mm <sup>2</sup>	Monopole Antenna	2.4GHZ & 3.9GHZ	43.3%	WBAN applications
[58]	2021	...	5 × 5 mm <sup>2</sup>	Dipole inspired patch antenna	1.85GHz	N78 5G, low, middle & high frequency, IoT bands respectively 84.2%, 53.6%, 21.2%, 84.2%, 50.1%	Metamaterial antenna for 4G, 5G, and NB-IoT applications
[59]	2021	Roger RO3003 1.5mm	30.21 × 30.21 mm <sup>2</sup>	AMC layer and a slotted monopole antenna	2.5GHz	95% in 1-g of phantom hand tissues	WBAN applications
[60]	2021	FR4 1.6 mm	14 × 14 mm <sup>2</sup>	..	1.81GHz & 3.79GHz	61.16% and 70.33% for 1 g and 10 g of tissue volumes	Random absorptions at L, S, and C Bands
[61]	2022	FR4 1.6 mm	9.8 × 9.8 mm <sup>2</sup>	Planer sleeve monopole antenna	3.5GHz	33% for 1 g and 35.6% for 10 g	Metamaterial absorber designed solely at 3.5 GHz for SAR reduction (from n78 devices)
This Work	...	FR4 1.6 mm	20 × 20 mm <sup>2</sup>	...	2.45 GHz & 3.5 GHz	....	Sensing, Wi-Fi & mid-range 5G communication

## Chapter 05

### Conclusion

#### 5.1 Introduction

The metamaterial absorber (MMA) in the microwave frequency range has been presented as a square split enclosed labyrinth maze-shaped structure. A new arrangement of square & circular ring resonators in the structure has been presented which provides the high absorbance of this MMA. The suggested structure's breadth and circular loop radii have been adjusted to maximize the absorption of the received signal at various operating frequencies. The absorptivity of the present MMA has been obtained as 99.4%, 91.65%, 98.75%, 95.37%, and 95.77% absorbance at five different frequencies 2.44 GHz, 3.57 GHz, 12.039 GHz, 15.516 GHz, and 16.713 GHz respectively. The surface current distributions and magnetic and electric field patterns in the MMA structures have been observed at these frequencies which provide the resonating behaviour of different frequencies. Applications involving Ku-band absorption and sensing may be suitable for the suggested MMA.

#### 5.2 Conclusion

In this work, Square Split Enclosed Labyrinth Maze Shaped Metamaterial Absorber for S-band and Ku-band applications as Hydrocarbon Sensing, Wi-Fi and Mid-range 5G by simulation study. The proposed patch comprises two square split-ring resonators (SSRR) generate five corresponding resonances at 2.44 GHz, 3.57 GHz, 12.039 GHz, 15.516 GHz and 16.713 GHz with 99.4%, 91.65%, 98.75%, 95.37% and 95.77% absorption, respectively. Also, The MMA peak reflection band is at 11.28 GHz, and the lowest band shift is 0.01 GHz between Heptane and Octane. Because the average sensitivity of the MMA is 1.4 GHz/ $\epsilon$  for different Hydrocarbon materials, applications involving Ku-band absorption and sensing may be suitable for the suggested MMA. Proposed structure can be scaled to other frequency bands for future various applications as medical imaging, wave tracking, energy harvesting and radar applications.

#### 5.3 Achievement

High absorption efficiency: Metamaterial absorbers have demonstrated high absorption efficiencies at specific frequencies or within narrow frequency bands. With careful design optimization, absorption efficiencies exceeding 90% have been achieved.

The permittivity, permeability for different resonance frequency (2.44 GHz, 3.57 GHz, 12.039 GHz, 15.516 GHz, and 16.713 GHz). We see that permittivity value is negative and

permeability value is positive. So we called this absorber is single negative material (SNG). Also the refractive Index value is zero at desired resonance frequency.

## **5.4 Limitation**

**Temperature and power handling:** Metamaterial absorbers are typically composed of various metallic and dielectric materials. Depending on the design, these materials may have limitations in terms of their temperature stability and power handling capabilities. Excessive heat or high-power incident waves can lead to material degradation or even failure.

**Manufacturing complexity:** The fabrication of metamaterial absorber can be challenging costly. Achieving the desired geometrical patterns and material compositions often involves advanced nanofabrication techniques such as electron beam lithography or focused ion beam milling. These processes may not be easily scalable or commercially viable for mass production.

**Sensitivity to manufacturing imperfections:** Metamaterial absorbers are highly sensitive to manufacturing imperfections, such as dimensional errors, material inhomogeneities, and surface roughness. Even slight deviations from the intended design parameters can significantly affect their absorption performance.

## **5.5 Future Work**

The proposed metamaterial absorber can be improved in future and used as SAR reduction, Wi-Fi, mid-range 5G, broad band absorber in communication bands, Tunability and configurability, Efficiency and loss reduction, energy harvesting, stealth technology, sensing etc.

These are just a few examples of the future directions in metamaterial absorber research. Continued advancements in material science, fabrication techniques, and electromagnetic modeling will likely lead to significant progress in overcoming the current limitations and unlocking new opportunities for metamaterial absorbers.

## References

- [1] D.R. Smith, J.B. Pendry, and M.C.K. Wiltshire, "Metamaterials and Negative Refractive Index." *Science*, vol. 305, no. 5685, pp. 788-792, 2004.
- [2] Design of antennas and Wireless Body Area Networks (no date) Antenna design. Available at: <http://www.eletel.p.lodz.pl/eng/index.php/research/telekomunikacja/design-and-application-of-metamaterials-3> (Accessed: 23 May 2023).
- [3] Abdulkarim, Y.I. et al. (2022) A review on metamaterial absorbers: Microwave to optical, *Frontiers*. Available at: <https://www.frontiersin.org/articles/10.3389/fphy.2022.893791/full> (Accessed: 23 May 2023).
- [4] Y. Gong, X. Li, and S. V. Hum, "Ultrathin, ultrawideband, tunable metamaterial absorber for solar energy harvesting," in *Applied Physics Letters*, vol. 100, no. 16, pp. 163901, 2012.
- [5] M. N. O. Sadiku, "Elements of Electromagnetics," in *IEEE Transactions on Education*, vol. 49, no. 4, pp. 558-560, Nov. 2006.
- [6] C. A. Balanis, "Advanced Engineering Electromagnetics," in *IEEE Transactions on Antennas and Propagation*, vol. 50, no. 2, pp. 316-317, Feb. 2002.
- [7] R. Garg, P. Bhartia, I. J. Bahl, et al., "Microstrip Antenna Design Handbook," in *IEEE Antennas and Propagation Magazine*, vol. 48, no. 2, pp. 175-176, April 2006.
- [8] R. W. Boyd, "Nonlinear Optics," in *Proceedings of the IEEE*, vol. 80, no. 12, pp. 2047-2049, Dec. 1992.
- [9] L. V. Keldysh, "Electromagnetic Waves in Uniaxial Crystals," in *IEEE Transactions on Antennas and Propagation*, vol. 33, no. 7, pp. 806-807, July 1985.
- [10] Admin (2023) Permittivity and permeability - definition, formula, SI units, permittivity of free space, relative permeability of materials, and faqs, BYJUS. Available at: <https://byjus.com/physics/permittivity-and-permeability/> (Accessed: 23 May 2023).
- [11] Admin (2023b) What is refractive index - refractive index of water, examples and formula, BYJUS. Available at: <https://byjus.com/physics/refractive-index/> (Accessed: 23 May 2023).
- [12] Specific absorption rate (no date) Specific Absorption Rate - an overview | ScienceDirect Topics. Available at: <https://www.sciencedirect.com/topics/engineering/specific-absorption-rate> (Accessed: 26 May 2023).
- [13] Rojas, J. (2022) What is 5G, what is it used for and how does it work?, Telefónica. Available at: <https://www.telefonica.com/en/communication-room/what-is-5g-what-is-it-used-for-and-how-does-it-work/> (Accessed: 23 May 2023).
- [14] 5G bands explained: How they work & why they matter (no date) Celona. Available at: <https://www.celona.io/5g-lan/5g->



- [28] V. G. Veselago, "The electrodynamics of substances with simultaneously negative values of  $\epsilon$  and  $\mu$ ," *Soviet Physics Uspekhi*, vol. 10, no. 4, pp. 509-514, 1968.
- [29] J. B. Pendry, A. J. Holden, W. J. Stewart, and I. Youngs, "Extremely low frequency plasmons in metallic mesostructures," *Physical Review Letters*, vol. 76, no. 25, pp. 4773-4776, 1996.
- [30] C. Caloz and T. Itoh, *Electromagnetic Metamaterials: Transmission Line Theory and Microwave Applications*. Hoboken, NJ: Wiley, 2006.
- [31] Landy, N.I. *et al.* (2008) *Perfect metamaterial absorber*, *Physical Review Letters*. Available at: <https://link.aps.org/doi/10.1103/PhysRevLett.100.207402> (Accessed: 26 May 2023).
- [32] Engheta, N. *et al.* (no date) 'DNG, SNG, Enz and MNZ metamaterials and their potential applications', *MELECON 2006 - 2006 IEEE Mediterranean Electrotechnical Conference* [Preprint]. doi:10.1109/melcon.2006.1653087.
- [33] Schilling, J. (2011) 'The Quest for Zero refractive index', *Nature Photonics*, 5(8), pp. 449–451. doi:10.1038/nphoton.2011.172.
- [34] Enoch, S. *et al.* (2002) 'A metamaterial for directive emission', *Physical Review Letters*, 89(21). doi:10.1103/physrevlett.89.213902.
- [35] Hang Zhou *et al.* (2009) 'A novel high-directivity microstrip patch antenna based on zero-index metamaterial', *IEEE Antennas and Wireless Propagation Letters*, 8, pp. 538–541. doi:10.1109/lawp.2009.2018710.
- [36] Jin, Y. and He, S. (2010) 'Enhancing and suppressing radiation with some permeability-near-zero structures', *Optics Express*, 18(16), p. 16587. doi:10.1364/oe.18.016587.
- [37] JIN, Y. and HE, S. (2008) 'Impedance-matched multilayered structure containing a zero-permittivity material for spatial filtering', *Journal of Nonlinear Optical Physics & Materials*, 17(03), pp. 349–355. doi:10.1142/s0218863508004184.
- [38] Edwards, B. *et al.* (2008) 'Experimental verification of epsilon-near-zero metamaterial coupling and energy squeezing using a microwave waveguide', *Physical Review Letters*, 100(3). doi:10.1103/physrevlett.100.033903.
- [39] Silveirinha, M.G., Alù, A. and Engheta, N. (2007) 'Parallel-plate metamaterials for cloaking structures', *Physical Review E*, 75(3). doi:10.1103/physreve.75.036603.
- [40] Alkurt, F.Ö. *et al.* (2018) 'Design of a dual band metamaterial absorber for Wi-Fi bands', *AIP Conference Proceedings* [Preprint]. doi:10.1063/1.5025979.
- [41] Wu, Y. *et al.* (2019a) 'A transparent and flexible microwave absorber covering the whole wifi waveband', *AIP Advances*, 9(2), p. 025309. doi:10.1063/1.5083102.
- [42] ofigh, F. *et al.* (2020) 'Polarization-insensitive metamaterial absorber for crowd estimation based on Electromagnetic Energy Measurements', *IEEE Transactions on Antennas and Propagation*, 68(3), pp. 1458–1467. doi:10.1109/tap.2019.2955275.

- [43] Ramachandran, T. *et al.* (2021) ‘Reduction of 5G cellular network radiation in wireless mobile phone using an asymmetric square shaped passive metamaterial design’, *Scientific Reports*, 11(1). doi:10.1038/s41598-021-82105-7.
- [44] Kundu, D. *et al.* (2019) ‘Design and analysis of printed lossy capacitive surface-based Ultrawideband low-profile absorber’, *IEEE Transactions on Antennas and Propagation*, 67(5), pp. 3533–3538. doi:10.1109/tap.2019.2902660.
- [45] Yuan, F. *et al.* (2020) ‘RCS reduction based on concave/convex-chessboard random parabolic-phased metasurface’, *IEEE Transactions on Antennas and Propagation*, 68(3), pp. 2463–2468. doi:10.1109/tap.2019.2940503.
- [46] Bakır, M. *et al.* (2017) ‘Microwave metamaterial absorber for sensing applications’, *Opto-Electronics Review*, 25(4), pp. 318–325. doi:10.1016/j.opelre.2017.10.002.
- [47] Prakash, D. and Gupta, N. (2021) ‘Applications of metamaterial sensors: A Review’, *International Journal of Microwave and Wireless Technologies*, 14(1), pp. 19–33. doi:10.1017/s1759078721000039.
- [48] Ozer, Z., Mamedov, A.M. and Ozbay, E. (2017) ‘Metamaterial absorber based multifunctional sensor application’, *IOP Conference Series: Materials Science and Engineering*, 175, p. 012059. doi:10.1088/1757-899x/175/1/012059.
- [49] Bakır, M. *et al.* (2018) ‘Sensory applications of resonator based metamaterial absorber’, *Optik*, 168, pp. 741–746. doi:10.1016/j.ijleo.2018.05.002.
- [50] Rajakani, K. (2022) ‘Design of a seven-band perfect metamaterial absorber for thz sensing applications’, *Pramana*, 96(4). doi:10.1007/s12043-022-02443-7.
- [51] Rajakani, K. (2022) ‘Design of a seven-band perfect metamaterial absorber for thz sensing applications’, *Pramana*, 96(4). doi:10.1007/s12043-022-02443-7.
- [52] Hoque, A. *et al.* (2020) ‘SNG and DNG meta-absorber with fractional absorption band for sensing application’, *Scientific Reports*, 10(1). doi:10.1038/s41598-020-69792-4.
- [53] Akarsu, G. *et al.* (2021) ‘A novel 5G wideband metamaterial based absorber for microwave energy harvesting applications’, 2021 8th International Conference on Electrical and Electronics Engineering (ICEEE) [Preprint]. doi:10.1109/iceee52452.2021.9415941.
- [54] Hasan, Md.M. *et al.* (2022) ‘Polarization insensitive dual band metamaterial with absorptance for 5G sub-6 ghz applications’, *Scientific Reports*, 12(1). doi:10.1038/s41598-022-12106-7.

- [55] Colaco, J. and Lohani, R.B. (2021) ‘Metamaterial based multiband microstrip patch antenna for 5G wireless technology-enabled IOT devices and its applications’, *Journal of Physics: Conference Series*, 2070(1), p. 012116. doi:10.1088/1742-6596/2070/1/012116.
- [56] Hussain, M. et al. (2023) ‘Metamaterials and their application in the performance enhancement of reconfigurable antennas: A Review’, *Micromachines*, 14(2), p. 349. doi:10.3390/mi14020349.
- [57] Naqvi, S.A. et al. (2022) ‘A novel meander line metamaterial absorber operating at 24 GHz and 28 GHz for the 5G applications’, *Sensors*, 22(10), p. 3764. doi:10.3390/s22103764.
- [58] Lakshmi, M.L. et al. (2023) ‘Polarization stable triband thin square-shaped metamaterial absorber’, *International Journal of Antennas and Propagation*, 2023, pp. 1–9. doi:10.1155/2023/6065300.
- [59] Siddiky, A.M. et al. (2022) ‘Double negative circular shaped inductively coupled metamaterial power splitter for the C-, X band applications’, *Optik*, 267, p. 169702. doi:10.1016/j.ijleo.2022.169702.
- [60] Siddiky, A. et al. (2022) ‘Double negative circular shaped inductively coupled metamaterial power splitter for the C-, X band applications’, *Optik*, 267, p. 169702. doi:10.1016/j.ijleo.2022.169702.
- [61] Wu, Y. et al. (2019) ‘A transparent and flexible microwave absorber covering the whole wifi waveband’, *AIP Advances*, 9(2), p. 025309. doi:10.1063/1.5083102.
- [62] Siddiky, A.M. et al. (2021) ‘Parabolic split ring resonator (PSRR) based MNZ metamaterial with angular rotation for WIFI/WiMax/Wireless/ISM band applications’, *Chinese Journal of Physics*, 71, pp. 753–769. doi:10.1016/j.cjph.2021.04.013.
- [63] Singh, P.K. et al. (2013) ‘Broadband MILLIMETERWAVE metamaterial absorber based on embedding of dual resonators’, *Progress In Electromagnetics Research*, 142, pp. 625–638. doi:10.2528/pier13070209.
- [64] Evangeline Persis, G.P. et al. (2022) ‘A compact tilted split ring multiband metamaterial absorber for energy harvesting applications’, *Materials Today: Proceedings*, 56, pp. 368–372. doi:10.1016/j.matpr.2022.01.206.
- [65] Hasan, Md. et al. (2019) ‘Electrically compact SRR-loaded metamaterial inspired quad band antenna for Bluetooth/WIFI/WLAN/WiMAX System’, *Electronics*, 8(7), p. 790. doi:10.3390/electronics8070790.
- [66] Hannan, Saif, Mohammad Tariqul Islam, Mohamed S. Soliman, Mohammad Rashed Iqbal Faruque, Norbahiah Misran, and Md Shabiul Islam. "A co-polarization-

insensitive metamaterial absorber for 5G n78 mobile devices at 3.5 GHz to reduce the specific absorption rate." *Scientific Reports* 12, no. 1 (2022): 11193.

- [67] A. Musa et al., "Polarization independent metamaterial absorber with anti-reflection coating nanoarchitectonics for visible and infrared window applications," *Materials*, vol. 15, no. 10, p. 3733, 2022.
- [68] A. Musa, M. L. Hakim, T. Alam, M. H. Baharuddin, and M. S. J. Singh, "Dual-band Metamaterial Absorber for Ka-Band Satellite Application," in *2021 7th International Conference on Space Science and Communication (IconSpace)*, 2021: IEEE, pp. 151-155.

I am sharing 'TT183005 & T183007 (TB).docx' with you ☆  
from WPS Office Inbox



Asif Rahman 📧 Jul 12

Please check the attachment Get WPS Office for PC: <https://www.wps.com/d/>



IIUC Central Lib... 2 days ago  
to me, Md. ▼

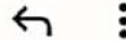

Dear Sir

*Assalamualaikum Warahmatullahi Wabarakatuh*

Plagiarism Report

I have attached the plagiarism report of your document.

If you need any more help or questions, please don't hesitate to contact me.

Sincerely Regards

Jahir Uddin

Lab Attendant

Library and Information Division

International Islamic University Chittagong

For more information

Email: [uzahir34@gmail.com](mailto:uzahir34@gmail.com)

Cell & WhatsApp: 01840745850

PABX: 1994

[Show quoted text](#)



TT183005 &...07 (TB).pdf



# TT183005 & T183007 (TB)

*by* liuc Central Library

---

**Submission date:** 12-Jul-2023 11:15AM (UTC+0530)

**Submission ID:** 2129981250

**File name:** TT183005\_T183007\_TB.docx (2.5M)

**Word count:** 7728

**Character count:** 44108

<b>26%</b>	<b>19%</b>	<b>13%</b>	<b>11%</b>
SIMILARITY INDEX	INTERNET SOURCES	PUBLICATIONS	STUDENT PAPERS

## PRIMARY SOURCES

<b>1</b>	<b>jnep.sumdu.edu.ua</b> Internet Source	<b>5%</b>
<b>2</b>	<b>byjus.com</b> Internet Source	<b>3%</b>
<b>3</b>	<b>www.frontiersin.org</b> Internet Source	<b>2%</b>
<b>4</b>	<b>Submitted to International Islamic University Chittagong</b> Student Paper	<b>2%</b>
<b>5</b>	<b>www.ncbi.nlm.nih.gov</b> Internet Source	<b>1%</b>
<b>6</b>	<b>Fatih Özkan Alkurt, Mehmet Bağmancı, Muharrem Karaaslan, Mehmet Bakır et al. "Design of a dual band metamaterial absorber for Wi-Fi bands", AIP Publishing, 2018</b> Publication	<b>1%</b>
<b>7</b>	<b>Alkesh Agrawal, Mukul Misra, Ashutosh Singh. "A dual broadband metamaterial absorber with concentric continuous and split rings</b>	<b>1%</b>

resonator structure", 2016 IEEE Uttar Pradesh Section International Conference on Electrical, Computer and Electronics Engineering (UPCON), 2016  
Publication

<b>8</b>	<b>Submitted to Durban University of Technology</b> Student Paper	<b>1%</b>
<b>9</b>	<b>www.collegesearch.in</b> Internet Source	<b>1%</b>
<b>10</b>	<b>Submitted to Texas A&amp;M University, College Station</b> Student Paper	<b>1%</b>
<b>11</b>	<b>www.esa.int</b> Internet Source	<b>1%</b>
<b>12</b>	<b>pubhtml5.com</b> Internet Source	<b>&lt;1%</b>
<b>13</b>	<b>Submitted to University of Leicester</b> Student Paper	<b>&lt;1%</b>
<b>14</b>	<b>dokumen.pub</b> Internet Source	<b>&lt;1%</b>
<b>15</b>	<b>lazarsci.com</b> Internet Source	<b>&lt;1%</b>
<b>16</b>	<b>www.researchgate.net</b> Internet Source	<b>&lt;1%</b>

17 Saif Hannan, Mohammad Tariqul Islam, Sami H. A. Almalki, Mohammad Rashed Iqbal Faruque, M. Salaheldeen M, Md. Shabiul Islam. "Rotational symmetry engineered, polarization and incident angle-insensitive, perfect metamaterial absorber for X and Ku band wireless applications", Scientific Reports, 2022  
Publication <1%

18 K. D. Möller. "Thick inductive cross shaped metal meshes", Journal of Applied Physics, 2002  
Publication <1%

19 Submitted to University of Ghana  
Student Paper <1%

20 www.science.gov  
Internet Source <1%

21 R. I. Nwosu. "A Comparative Study of LiFi and Other Data Transfer Mediums", Current Journal of Applied Science and Technology, 2019  
Publication <1%

22 Saif Hannan, Mohammad Tariqul Islam, Mohamed S. Soliman, Norsuzlin Binti Mohd Sahar et al. "A Filling-Factor Engineered, Perfect Metamaterial Absorber for Multiple Applications at Frequencies Set by IEEE in C

and X Bands", Journal of Materials Research and Technology, 2022  
Publication

23 Submitted to University of Durham  
Student Paper <1%

24 Submitted to Kuwait University  
Student Paper <1%

25 Reza Dehbashi, Taras Plakhotnik, Timo A. Nieminen. "Far-Field Subwavelength Straight-Line Projection/Imaging by Means of a Novel Double-Near-Zero Index-Based Two-Layer Metamaterial", Materials, 2021  
Publication <1%

26 www.scielo.br  
Internet Source <1%

27 Submitted to Institute of Business Studies  
Student Paper <1%

28 Submitted to Loughborough College  
Student Paper <1%

29 Submitted to University of Northumbria at Newcastle  
Student Paper <1%

30 blog.satsearch.co  
Internet Source <1%

31 Submitted to Charotar University of Science And Technology <1%

32	Lecture Notes in Electrical Engineering, 2016. Publication	<1 %
33	Submitted to Middle East Technical University Student Paper	<1 %
34	Submitted to Universiti Malaysia Sarawak Student Paper	<1 %
35	Submitted to University of Melbourne Student Paper	<1 %
36	shizuoka.repo.nii.ac.jp Internet Source	<1 %
37	www.smart-safe.com Internet Source	<1 %
38	"Handbook of Antenna Technologies", Springer Science and Business Media LLC, 2016 Publication	<1 %
39	Submitted to Savitribai Phule Pune University Student Paper	<1 %
40	Submitted to University of Southampton Student Paper	<1 %
41	Submitted to University of Wales central institutions Student Paper	<1 %

42	Abbas, Ghulam, Shakeel Ahmed, Aqeel A. Syed, and Qaisar Abbas Naqvi. "Scattering from a topological insulator circular cylinder coated with DNG/MNG/ENG metamaterials", Optik - International Journal for Light and Electron Optics, 2016. Publication	<1 %
43	pericles.pericles-prod.literatumonline.com Internet Source	<1 %
44	www.dtic.mil Internet Source	<1 %
45	Submitted to Ahsanullah University of Science and Technology Student Paper	<1 %
46	Moad Adel Suliman, Adel Saad Emhemmed, Ibrahim Asaad Aref. "Suppression of Mobile Phone Radiation in Human Head Using Metamaterial", 2023 IEEE 3rd International Maghreb Meeting of the Conference on Sciences and Techniques of Automatic Control and Computer Engineering (MI-STA), 2023 Publication	<1 %
47	Soemphol, C., and N. Wongkasem. "Design of near-zero refractive index metamaterials using $\epsilon$ and $\mu$ near-zero media", 2012	<1 %

48	blog.stackprogramer.xyz Internet Source	<1 %
49	etd.aau.edu.et Internet Source	<1 %
50	sea.pcmag.com Internet Source	<1 %
51	www.jpier.org Internet Source	<1 %
52	Campione, Salvatore, Shiji Pan, S Hosseini, Caner Guclu, and Filippo Capolino. "Electromagnetic Metamaterials as Artificial Composite Structures", Electrical Engineering Handbook, 2012. Publication	<1 %
53	Submitted to Florida Institute of Technology Student Paper	<1 %
54	Submitted to Higher Education Commission Pakistan Student Paper	<1 %
55	Mohammad Lutful Hakim, Touhidul Alam, Mohammad Tariqul Islam, Mohd Hafiz Baharuddin, Ahmed Alzamil, Md. Shabiul Islam. "Quad-Band Polarization-Insensitive	<1 %

Square Split-Ring Resonator (SSRR) with an  
Inner Jerusalem Cross Metamaterial Absorber  
for Ku- and K-Band Sensing Applications",  
Sensors, 2022  
Publication

56	Saif Hannan, Mohammad Tariqul Islam, Mohamed S. Soliman, Mohammad Rashed Iqbal Faruque, Norbahiah Misran, Md. Shabiul Islam. "A co-polarization-insensitive metamaterial absorber for 5G n78 mobile devices at 3.5GHz to reduce the specific absorption rate", Scientific Reports, 2022 Publication	<1 %
57	acikbilim.yok.gov.tr Internet Source	<1 %
58	bdtic.com Internet Source	<1 %
59	slideplayer.com Internet Source	<1 %
60	www.ijecs.in Internet Source	<1 %
61	www.ijmra.us Internet Source	<1 %
62	Rui You, Wenjun Gao, Chunbang Wu, Hongbin Li. "Technologies for Spacecraft Antenna	<1 %