



**BACHELOR OF SCIENCE IN ELECTRONIC AND TELECOMMUNICATIONS  
ENGINEERING**

**Design and Evaluation of 20Gbps Inter Satellite Optical Wireless  
Communication System for improved distance and performance**

Submitted by

**Mohammad Faisal**

T-151022

**Kazi Ishtiaq Hasan Noman**

T-151009

Supervised by

**Engr. Abdul Gafur**

Associate Professor

Department of ETE

International Islamic University Chittagong

Department of Electronic and Telecommunications Engineering

International Islamic University Chittagong

Kumira, Sitakunda, Chattagram

September, 2019

## **DEDICATION**

This thesis work is dedicated to all of our honourable teachers and parents.

## **CERTIFICATE OF APPROVAL**

The project entitled as “Design and Evaluation of 20Gbps Inter Satellite Optical Wireless Communication System for improved distance and performance” submitted by Mohammad Faisal, bearing ID No: T-151022 and Kazi Ishtiaq HasanNoman, bearing ID No: T-151009, to the Department of Electronic and Telecommunications Engineering (ETE) of International Islamic University Chittagong (IIUC) has been accepted as satisfactory for the partial fulfillment of the requirements for the Degree of Bachelor in Electronic and Telecommunications Engineering and approved as to its style and contents for the examination held on 14<sup>th</sup> September 2019.

Approved by

**Engr. Abdul Gafur**

Supervisor

Associate Professor

Department of Electronics and Telecommunications Engineering

Faculty of Science and Engineering

International Islamic University Chittagong

Kumira, Sitakunda, Chittagong.

## **CANDIDATES DECLARATION**

It is hereby declared that the work presented in this thesis has not been submitted elsewhere for the award of any degree or diploma, does not contain any unlawful statement.

---

Mohammad Faisal  
T-151022

---

Kazi Ishtiaq Hasan Noman  
T-151009

## ACKNOWLEDGEMENTS

In the name of Allah, the Entirely Merciful, the Especially Merciful. All praises and glory is to Allah (SWT) for blessing us with opportunities abound and showering upon us His mercy and guidance all through the life. And may peace and blessings of Allah be upon Prophet Muhammad (pbuh), a guidance and inspiration to our lives. We express our sincere gratitude and indebtedness to our thesis supervisor **Engr. Abdul Gafur**, for his initiative in this field of research, valuable guidance, encouragement throughout the time of research. We express our thankfulness to **Md. Jashim Uddin**, Head of the Department of Electronic and Telecommunications Engineering, IIUC for providing us with best facilities in the department and his timely suggestions. We are also thankful to **Sayed Zahidur Rashid**, Convener of our thesis for his dedication and sacrifice. We also express our sincere gratitude to all our teacher for giving us the best effort throughout our entire academic years. And we remember our parents for their support in our life till now. And we also express gratitude our friends, well-wishers for their directly or indirectly involvement in the completion of this thesis work.

## **ABSTRACTS**

In this present day world, satellite innovation plays a significant role. It is necessary to be sent data which obtained from the different orbits of satellites. So, it is required to have a link between the satellites to send these data. Hence, Inter satellite Optical Wireless Communication (Is-OWC) approach arises. Is-OWC system is high, small size, bandwidth, and light weight, low power and low cost and is therefore chosen over existing microwave satellite systems for reaching in space in the future. However the system has various limitations such as attenuations due to climate conditions, glimmers which limit its performance and diminishes its accessibility. The system also has trade-offs in the efficient design for higher distance coverage with better performance. In this paper, a 20 Gbs Is-OWC system with improved performance and longer distance is introduced. The proposed system is designed and evaluated using Optisystem Software 16 version. The proposed system provides better performance of Q factor and BER for the distance of 20,000 km. The distance is improved by using optical amplifier in the transmitter.

# TABLE OF CONTENTS

Dedication.....	i
Certificate of Approval.....	ii
Candidates Declaration.....	iii
Acknowledgements.....	iv
Abstract.....	v
List of Figures.....	ix
List of Tables.....	xi
List of Symbols and Abbreviations.....	xii

## CHAPTER 01 INTRODUCTION

1.1 Introduction.....	1
1.2 Overview of Satellites .....	2
1.3 Intersatellite Link Development .....	4
1.4 Optical Wireless Communication Concepts .....	5
1.4.1 Optical Wireless System (OWC) system .....	7
1.4.2 System performance.....	10
1.4.3 Attenuation and Link Power Budget .....	11
1.5 Intersatellite Optical Link Application .....	12
1.5.1 Data Relay for Inter Orbit Satellites .....	12
1.5.2 Connecting Constellations of Satellites .....	14

1.6 Related Research .....	15
1.7 Project Objectives .....	18
1.8 Scope of Work .....	18
1.9 Problem Statement .....	19
1.10 Thesis Outline .....	19

## **CHAPTER 2 LITERATURE REVIEW**

2.1 Paper Review .....	21
------------------------	----

## **CHAPTER 03 PROJECT METHODOLOGY AND SYSTEM MODELLING**

3.1 Introduction .....	30
3.2 Designed procedure .....	31
3.2.1 Study on OWC system .....	32
3.2.2 Study on Intersatellite Link System .....	32
3.2.3 Design the IsOWC Basic System Model.....	32
3.2.4 IsOWC system simulation for performance characterization .....	33
3.2.5 Result Analysis .....	33
3.2.6 Thesis Writing and Presentation .....	33
3.3 Opti-system Software .....	33
3.4 System Design Components .....	33
3.4.1 Is-OWC Transmitter Design .....	34
3.4.2 OWC Channel .....	35
3.4.3 Is-OWC Receiver Design .....	36

3.5 System Model in OptiSystem.....	37
3.6 Result Analysis .....	40
3.7 Presentation and Thesis Writing .....	40
3.8 Conclusions .....	40

## **CHAPTER 04 RESULT ANALYSIS**

4.1 Introduction .....	41
4.2 Relationship between Q-factor and Bit rates with Distance of Intersatellite Link .....	41
4.3 Final Characteristics of the proposed system .....	45
4.4 Comparison of the proposed system with existing work .....	45
4.5 Conclusions .....	45

## **CHAPTER 05 CONCLUSION**

5.1 Conclusion .....	46
5.2 Future Scope and Recommendation .....	47
References	48

# LIST OF FIGURES

<b>Figure No</b>	<b>Page No</b>
1.1: overview of the satellite	2
1.2: Earth Satellite Communication Orbits	3
1.3: Intersatellite link achieved first between Artemis and SPOT-4 in March 2013	4
1.4: Non-linear transfer characteristic of the considered optical front-end, $(x)$ , and the linearized characteristic after pre-distortion, $(x)$	4
1.5: IsOWC basic system block diagram for simplex communication	7
1.6: Optical modulation process where input light is varied according to electrical signal to produce light pulses	8
1.7: Optical antennae increase the signal divergence	9
1.8: APD photodetector structure	10
1.9: Concept of data relay for inter orbit IsOWC	13
1.10: Data relay methods a) conventional b) using intersatellite data relay	14
1.11: Constellations of satellite orbiting Earth	15
1.12: Link attenuation for (a) LEO-LEO link and (b) GEO-GEO link	14
1.13: Optical satellite network creating a global connection	16
1.14: High-level optical intersatellite communication systems	17
3.1: The project methodology	31
3.2: NRZ encoding technique	34
3.3: Mach-Zehnder Modulator varies the light intensity according to voltage	35

3.4: BER analyzer is connected to the transmitter when without 3R regenerator	36
3.5: Connection of the BER analyzer to the 3R regenerator	37
3.6: Is-OWC first designs with basic subsystems	38
3.7: Is-OWC first designs with basic subsystems (simples design)	38
3.8: Is-OWC design with amplifier for higher distances	39
4.1: Q factor Curve using optical amplifier	41
4.2: BER Pattern	42
4.3: Eye Diagram output using CW laser	43
4.4: Minimum BER curve	44
4.5: Transmitted and Received power by the system	44

## LIST OF TABLES

<b>Table No</b>	<b>Title</b>	<b>Page No</b>
4.4	Comparison of the proposed system with existing work	45

## LIST OF ABBREVIATIONS

OWC	-	Optical Wireless Communication
IsOWC	-	Intersatellite Optical Wireless Communication
RF	-	Radio Frequency
SCORE	-	Signal Communication by Orbital Relay
LEO	-	Low Earth Orbit
MEO	-	Medium Earth Orbit
GEO	-	Geosynchronous Orbit
BER	-	Bit Error Rate
NASA	-	National American Space Agency
TDRSS	-	Tracking and Data Relay Satellite System
ESA	-	European Space Agency
SPOT-4	-	Satellite Pour L'Observation De La Terre 4
TT&C	-	Telemetry, Tracking and Communication
LED	-	Light Emitting Diode
ILD	-	Injecting Laser Diode
APD	-	Avalanche Photodiode
NRZ	-	Non-return Zero
CW	-	Continuous wave

# CHAPTER 01

## INTRODUCTION

### 1.1 Introduction

By April 2009, there increases 6124 satellites orbiting Earth and this number year by year [1]. Today, in various significant areas, the artificial satellites are utilized for the purpose of communication to pass the signal with high data rate by covering enormous distance. Transmitting and receiving data in satellite communication using different types of wireless communication medium in radio frequency (RF) and microwave frequency form experiences various limitations like license requirement, fixed bandwidth, high cost and interference occurrence between signals [2]. Hence, a new link named optical wireless communication (OWC) channel is developed to establish a medium between satellites termed as Inter-satellite Optical Wireless Communication (Is-OWC) system. The Systems of Is-OWC have demonstrated as a profitable toward lots of applications. The system has more advantages over presently being used microwave communication systems. The Is-OWC systems by the name implies is used between two satellites as a wireless media to transmit optical signal at the free space to a combination of optical and wireless communication networks [3]. Regardless of these different advantages, Is-OWC systems are highly concerned about some errors that are generally occurred within the satellite system. Such errors referred to the pointing error or misalignment error which is generally known as phenomenon of scintillation. The quality of inter-satellite link (ISL) distance relies upon various factors, such as operating wavelength, receiver sensitivity, input signal power and the modulation scheme used and various system techniques, diversity performances etc. In order to renumerate the pointing error that occurred Is-OWC system and improve Q factor by reducing BER, some techniques are applied such as using amplifier to amplify received noise power and filtration of noise power. Divergence of angel transmitter is very extremely rarely used to remove the problem of power dissipation [3] [4]. The IS-OWC system analysed for data rate of 40Gbs and distance of 5,000 km by using channel diversity technique [5]. By using QPSK modulation technique, 36,000 km distance achieved at data rate of 2.5Gbs and attenuation of 25 dB/km in Is-OWC system [6]. Besides all these, an Is-OWC system

which is developed using space diversity and receiver polarization diversity along with NRZ modulation at operating wavelength of 1550 nm which provides Q factor 6.8 with achievable bit rate 7.63Gbps on link distance of 6000 km [7]. The link of the inter satellite is developed for the purpose of long distance but due to weather conditions, climate and tacking, the system performance becomes reduced such Q factor reduced and BER become increased.

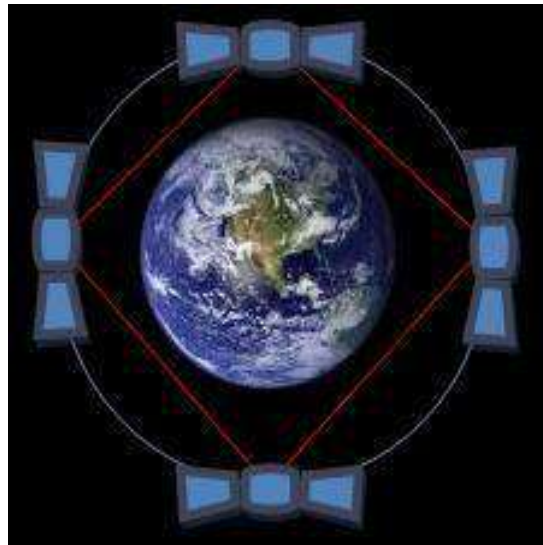

Figure 1.1: overview of the satellite

After analysing all above works, a 20Gbs Is-OWC system with improved distance and performance is introduced. The proposed system is designed and evaluated using Optisystem Software version. The proposed system provides better performance of Q factor and BER for the distance 20,000 km.

## 1.2 Satellite Overviews

In space, if an object revolves another object is called a satellite. The Moon is a satellite to Earth and the Earth is a satellite to the Sun. Those are natural satellite. In 1945, Arthur Clarke wrote on the possibilities of having manmade satellites that could be able to relay telephone channels and broadcast programs. Thirteen years later, the first communication satellite named SCORE (Signal Communication by Orbital Relay) was launched and proved that Clarke's theory was indeed possible. Following the success of SCORE, many more satellites were launched by

the United States, Russia, United Kingdom and Canada. Since then, satellites are launched up to space for many applications such as for communication, remote sensing, scientific research and global positioning.

Satellites revolve around Earth at their own orbit and there are three commonly used orbits for satellites. Low Earth Orbit (LEO) is the orbit closest to Earth with altitude of 100km to 5,000km. LEO satellites take from 2 to 4 hours to rotate around Earth. This orbit is commonly used for multi-satellite constellations where several satellites are launched up to space to perform a single mission. The Medium Earth Orbit (MEO) is from 10,000km to 20,000km altitude and the orbital period is from 4 to 12 hours. MEO orbit is usually occupied by remote sensing satellites. Communication satellites for broadcasting and telephone relay is placed in the Geosynchronous Orbit (GEO) which has 36,000km altitude from Earth. A GEO satellite takes 24 hours to rotate around Earth which makes it seem like stationary from Earth's point of view [4]. Figure 1.2 shows the satellite orbits around Earth.

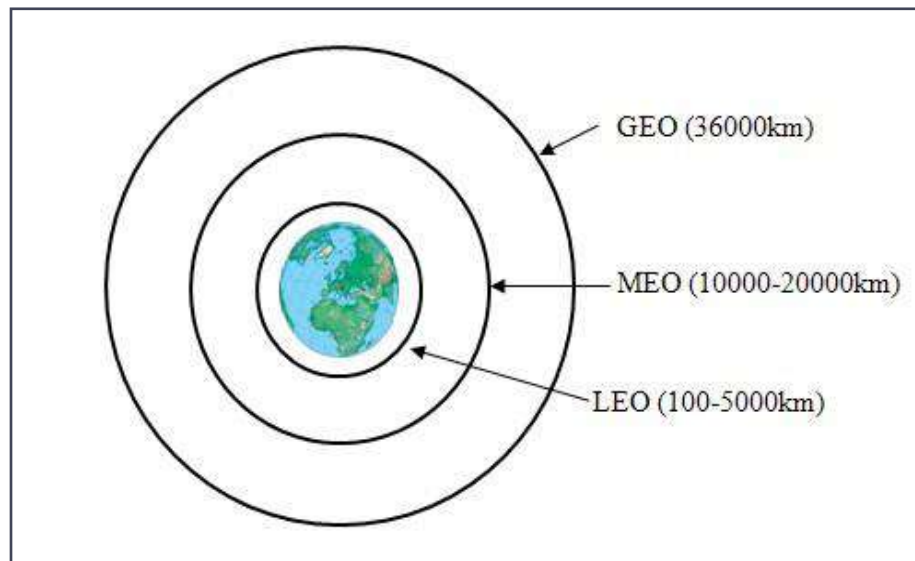

Figure 1.2 Earth Satellite Communication Orbits

### 1.3 Intersatellite link development

Intersatellite links have been employed on several satellite systems such as Iridium and National American Space Agency (NASA)'s Tracking and Data Relay Satellite System (TDRSS) where RF is used to link the satellites. However, optical links has been proven to provide higher bit rates and better efficiency than RF link. Hence, several satellites have been implanted with OWC intersatellite links such as European Space Agency (ESA)'s Artemis and Japan's Kirari satellites. The first intersatellite communication employing optical link was successfully achieved on March 2003 between Artemis and French satellite named Satellite Pour L'Observation De La Terre 4 or SPOT-4 [6]. The simplex communication from Artemis to SPOT-4 was done by using data transmitted at 50Mbps with signal wavelength of 850nm and optical signal with the power of 120mW. Artemis was placed in the GEO satellite while SPOT-4 was in LEO at altitude of 832km. In December 2005, a full-duplex communication between Artemis and Kirari was achieved. These two experiments have shown that IsOWC is possible. Figure 2.1 shows the overview of optical communication link between Artemis and SPOT-4 [7].

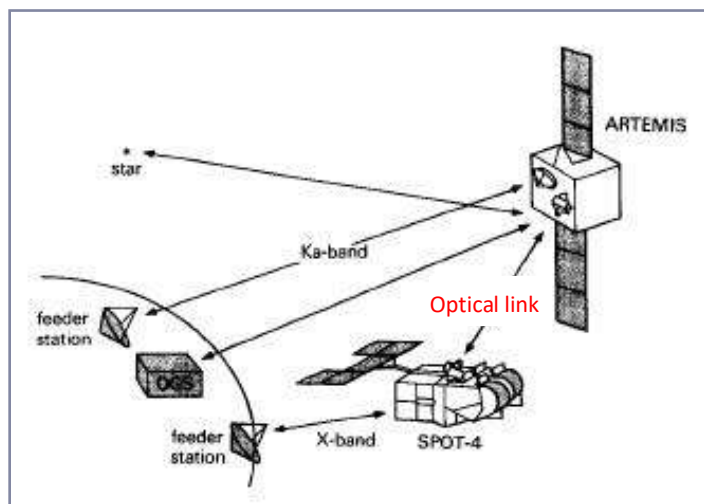

Figure 1.3 Intersatellite link achieved first between Artemis and SPOT-4 in March 2013

## 1.4 Optical Wireless Communication Concepts

It is different from RF system links, optical wireless communication system (OWC) uses light at near-infrared frequency to communicate. There are three main communication parts consist of OWC system which are transmitter, optical wireless channel which is also known as propagation channel and the last part is receiver. The OWC system is much similar with free space optics and fibre optic communication where the difference relies only in the propagation medium. OWC channel is considered to be outer space where it is assumed to be vacuum and free from atmospheric attenuation factors.

The optical wireless channel has been shown to be a linear, time-invariant, memoryless system with an impulse response of a finite-duration. Line-of-sight (LOS) and non-line-of-sight (NLOS) optical wireless channels can be accurately modeled by the rapidly decaying exponential impulse response function  $h(t) = g_{h(\text{opt})}h_{\text{norm}}(t)$ , where  $h_{\text{norm}}(t) = U(t)6a^6/(t+a)^7$ .

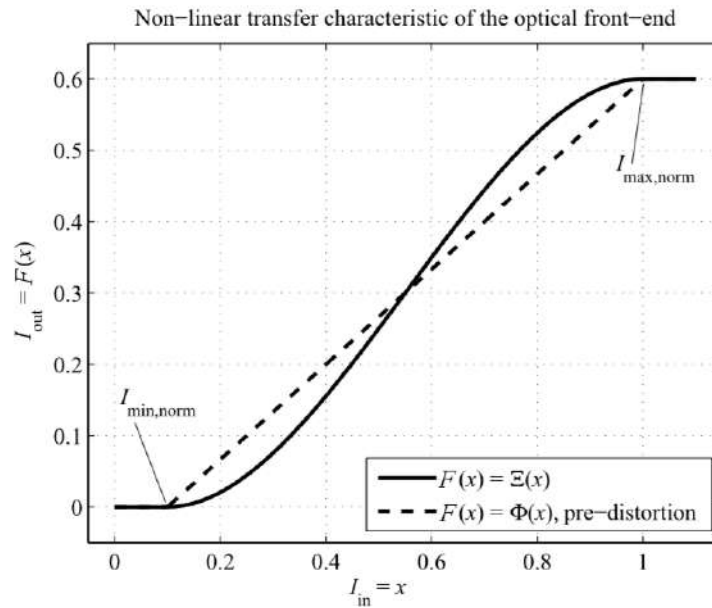

Figure 1.4 Non-linear transfer characteristic of the considered optical front-end,  $(x)$ , and the linearized characteristic after pre-distortion,  $(x)$ .

Here,  $g_{h(\text{opt})}$  stands for the optical path gain coefficient,  $U(\cdot)$  is the unit step function. The 3-dB coherence bandwidth of the channel can be expressed as  $B_c = 1/(5D)$ . RMS de-lay spreads

between 1.3 ns and 12 ns are reported for LOS links, whereas RMS delay spreads between 7 and 13 ns are reported for NLOS links. The channel taps in the vector  $\mathbf{h}$  are obtained by sampling of the channel impulse response at the sampling frequency of the received signal,  $y$ .

In multi-carrier systems such as OFDM-based OWC, the RMS delay spread is significantly shorter than the symbol duration, and therefore the equalization process is considerably simplified to single-tap equalization. The ISI and the inter-carrier interference (ICI) are completely eliminated by the use of a large number of subcarriers and a cyclic prefix (CP) which has a negligible effect on the electrical SNR requirement and spectral efficiency. Thus, the dispersive optical wireless channel is transformed into a flat fading channel over the sub-carrier bandwidth. For example, the ISI from maximum delay spreads of up to 100 ns can be compensated by a CP of 2 samples at a sampling rate of 20 MHz. For a fast Fourier transform (FFT) size of 1024, this result in a negligible reduction of the electrical SNR requirement with 0.01 dB and a reduction of the spectral efficiency of 0.2%. Therefore, the channel can be safely considered as flat fading over the entire OFDM frame for bandwidths up to 20 MHz and it can be primarily characterized by the optical path gain coefficient,  $g_{h(\text{opt})}$ . A large number of subcarriers, *e.g.* greater than 64, also ensures that the time domain signal follows a close to Gaussian distribution. This assumption greatly simplifies the derivations throughout the thesis. In addition, the CP transforms the linear convolution with the channel into a cyclic convolution, facilitating a single-tap linear FFE and eliminating the need for a non-linear DFE. Even though the channel can be considered as flat fading over the individual subcarriers, the non-flat channel frequency response over the entire OFDM frame in the case of a large frame bandwidth still leads to an SNR penalty for the average frame BER. The single-tap equalizer is generally paired with bit and power loading, in order to minimize this SNR penalty. Here, the gain factor of the equalizer,  $G_{\text{EQ}}$ , is obtained via a Monte Carlo simulation. Link parameters such as the optical center frequency, the mutual orientation and position of the transmitter and receiver in an indoor setup and their field of view (FOV), the responsivity and the photosensitive area of the detector, and the average radiated optical power of the transmitter determine the optical path gain coefficient,  $g_{h(\text{opt})}$  and therefore, the electrical path gain coefficient,  $g_{h(\text{elec})}$ , from (3.3). Since, however,  $g_{h(\text{elec})}$  is merely a factor in the equalization process, a change in  $g_{h(\text{elec})}$  results in an equal SNR penalty for all the considered systems. Therefore,  $g_{h(\text{elec})} = 1$  is assumed for simplicity. In general, the maximum information rate of the OWC system is achieved, when the coherence bandwidth of the channel

is significantly larger than the signal bandwidth, *i.e.* when the channel is considered as flat fading with an impulse response of  $h(t) = \delta(t)$ , where  $\delta(\cdot)$  is the Dirac delta function. Equivalently, the maximum information rate is achievable for a channel frequency response of  $jH(f)j^2 = 1$ . In this study, a perfect synchronization between the transmitter and the receiver is assumed in the processing of the information-carrying signal. In addition, a perfect matched filtering and perfect channel knowledge at the receiver and the transmitter are assumed for the purposes of equalization and bit and power loading.

### 1.4.1 Optical Wireless System (OWC) System

As we know, the basic Optical Wireless System (OWC) system consists of three primary blocks as Transmitter, propagation medium and a receiver. The basic block diagram of an Is-OWC system is shown in Figure 1.4 which shows that the transmitter is in the first satellite and the receiver is in the second satellite. The space which is generally stay in free space is the propagation medium is generally called OWC channel which is used for transmitting the light signal from satellite 1 transmitter to satellite 2 receivers.

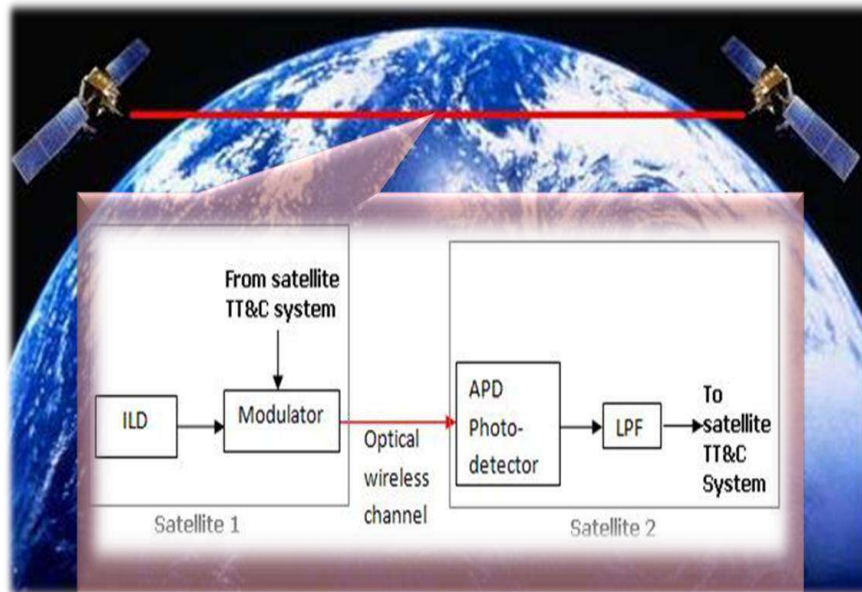

Figure 1.5 Is-OWC basic system block diagram for simplex communication

The Is-OWC transmitter receives data from the satellite's Telemetry, Tracking and Communication (TT&C) system. The data that usually transmitted by a satellite are such as the

satellite position and attitude tracking, captured image for remote sensing satellite, or even voice data for telephone network relaying satellite.

The most important component in optical signal is LS (Light Source) since communication is done by transmitting light. Light-emitting diode (LED) and injected laser diode (ILD) are two types of optical light source commonly used in optical communication. These devices are commonly made from semiconductor materials whereby the interaction between positively charge semiconductor and negatively charge semiconductor produces photons or light energy [8]. The output light emitted by the ILD is monochromatic, coherent and has high radiance which makes it suitable for long distance free space transmission. The light generated by the laser can travel much further than the light emitted by LED. Hence, ILD is used for Is-OWC system.

Signal which comes from TT&C system and optical signal is the electric signal generally from the laser will be modulated by an optical modulator which named as MZ modulator before it is transmitted out to space. An optical modulator varies the intensity or amplitude of the input light signal from ILD according to the electrical signal. This is done by changing optical parameters such as refractive index, reflection factor and transmission factor of the optical modulator that is made from fiber waveguides. Figure 1.5 illustrates the modulation process of an optical modulator [9].

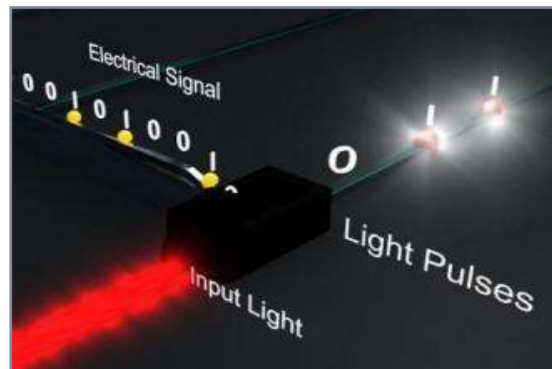

Figure 1.6 Optical Modulation Process where input light is varied according to electrical signal to produce light pulses

The optical modulator produces light pulses which are the output light pulses are transmitted in the transmission medium which is called OWC channel in the Is-OWC system to the

receiving satellite. The OWC channel free faces lots of challenges of losses due to subjecting of free space optics such as weather atmospheric attenuation like other fibre optics. Beside these, the only challenges faced by OWC are signal attenuation at higher distances. Optical antennae or optical lenses can be used at the transmitter and the receiver. The optical antennae allow wider light beam divergence and detection. An optical antenna is actually a lens or a telescope that is place before and after the transmission medium as shown in Figure 1.6.



Figure 1.7 The light divergence increased by Optical Antennae

Similarly as we know, the receiving end of the Is-OWC signal consists of a photodiode and a low pass filter. A device that receives and detects the optical signal and converts it into electrical signal is called a photo diode. Like an optical light source, photodiodes is made from positive and negatively charged semiconductor junction that is connected in reverse bias. When photons strike the junction, electrical signal will be created. Avalanche photodiode (APD) is used in long distance free space optical data transmission due to its characteristics of producing high amplification for low or weak light signals. Amplification in APD photodetector or avalanche phenomenon occurs when charged electrons are introduced in such high electric field area and collide with neutral semiconductor atoms, thus generating other carriers and this collision. This process is then repeated to effectively amplify the limited number of carriers. Figure 1.7 shows the structure of APD photodetector that consists of two pn junctions which produces the internal gain [10].

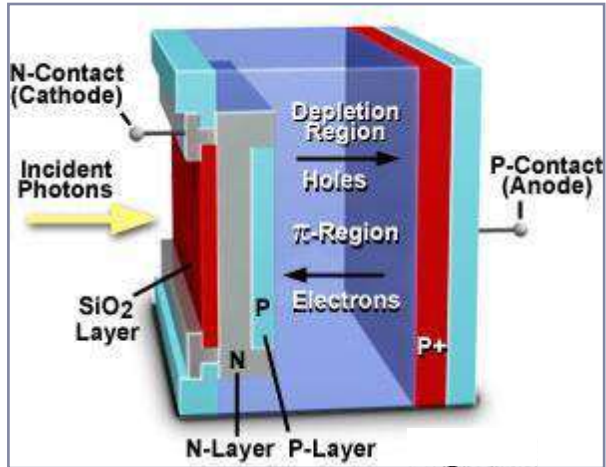

Figure 1.8 APD photodetector structure

### 1.4.2 System performance

The system performance can be evaluated in many ways such as by analyzing the BER and Q-factor. BER can be said to be the ratio of the number of bit errors detected in the receiver and the number of bits transmitted. Bit errors happen as the result of incorrect decisions being made in a receiver due to the presence of noise on a digital signal [11]. Meanwhile, Q-factor is a measurement of the signal quality. It is proportional to the system's signal to noise ratio. In optical system, the BER is typically too small to measure hence Q-factor is more suitable to be used. The relationship between BER and Q-factor can be given as

$$BER = \frac{1}{2} \operatorname{erfc} \left( \frac{Q}{\sqrt{2}} \right) \approx \frac{1}{\sqrt{2\pi}Q} \exp \left( -\frac{Q^2}{2} \right) \dots\dots\dots (1.1)$$

Where BER = bit error rate, Q= Quality factor, exp = exponential function and erfc refers to error function.

From the equation 1.1, it can be seen that the BER is inversely proportional to Q-factor. Therefore, if the system's error increases, the Q factor will thus decrease.

### 1.4.3 Attenuation and Link Power Budget

Friis transmission equation is given below to governed transmission in the medium. [10]

$$P_R = P_T G_T G_R L_T L_R \left(\frac{\lambda}{4\pi R}\right)^2 \dots\dots\dots (1.2)$$

Where  $P_R$  = Power of transmitting antenna,  $P_T$  = Receiving antenna power,  $G_T$ = The gain of the transmitting antenna,

$G_R$  = The gain of the receiving antenna,  $\lambda$  = Operating wavelength and  $R$ = The distance link between Tx and Rx

Here, Transmitting antenna gain is given by  $G_T$  as

$$G_T = (\pi G_T / \lambda)^2 \dots\dots\dots (1.3)$$

The gain of the receiver is given by

$$G_R = (\pi G_R / \lambda)^2 \dots\dots\dots (1.4)$$

The factor of the transmitting loss is defined by  $L_T$  as

$$L_T = \exp(-G_T \Theta_T^2) \dots\dots\dots (1.5)$$

The factor of the receiving loss is defined by  $L_R$  as

$$L_R = \exp(-G_R \Theta_R^2) \dots\dots\dots (1.6)$$

Where  $\Theta_T$  is the loss of the transmitter and  $\Theta_R$  is the loss of the receiver.

## **1.5 Intersatellite Optical link Application**

Lots of Applications are exists in Is-OWC system where satellites need to communicate with each other. Data relay between inter orbit satellite and other is to connect satellite in constellation are the most useful application of Is-OWC.

### **1.5.1 Data Relay for Inter Orbit Satellites**

Similarly the orbits which are called GEO, LEO, MEO satellites are ordinary from the earth. This means that the satellite is not constantly in its Earth station's view. For this reason, by the use of the inter satellite link, data can be sent LEO and MEO satellite at every time by using a GEO satellite as relay. Data can also be relayed from one LEO satellite to another if they have line of sight. This concept is shown in Figure 1.8. Currently LEO satellites typically operate with limited and non-real-time support through a single or network of earth stations. Each communication session is limited in duration as are the number of sessions per day. In the current design and deployment of LEO satellites, there is no "on-demand" support or any communication system to support this type of scenario. This means that LEO satellite operators are unable to provision for real-time reconfiguration, asset redirection or carry out faster anomaly resolution. Leveraging a commercially available Geosynchronous Earth Orbit (GEO) satellite constellation system, Add value developed an innovative solution with its proprietary IDRS terminal, coupled with the established Inmarsat's global communication services, to provide a mean to relay data to and from an orbiting LEO satellite. The IDR solution is capable of providing on-demand 24 by 7 data connection services and mid-size data transfer and it is capable of supporting data rates in excess of 200 Kbps for LEO satellites in all orbital inclinations and at altitudes of up to 1000 km. This is certainly a game changer in the way most commercial LEO satellite operators will be able to operate their satellites. By eliminating the in-sight-of-an-Earth-station limitation and providing an on-demand real-time communications link to LEO satellites, this could provide a reliable platform for new market opportunities for LEO satellite operators in the foreseeable future. The aim is to provide economical low latency, on-demand data communications services to support LEO satellite operations via IDR, that will operate via the highly reliable Inmarsat-4 constellation of GEO L-band communications satellites and Inmarsat's mature Broadband Global Area Network (BGAN), and be made available to LEO satellite operators across the globe.

The European Data Relay System (EDRS) system is a European constellation of GEO satellites that relay information and data between satellites, spacecraft, UAVs, and ground stations. The designers intend the system to provide almost full-time communication, even with satellites in low Earth orbit that often have reduced visibility from ground stations. It makes on-demand data available to, for example, rescue workers who want near-real-time satellite data of a crisis region.

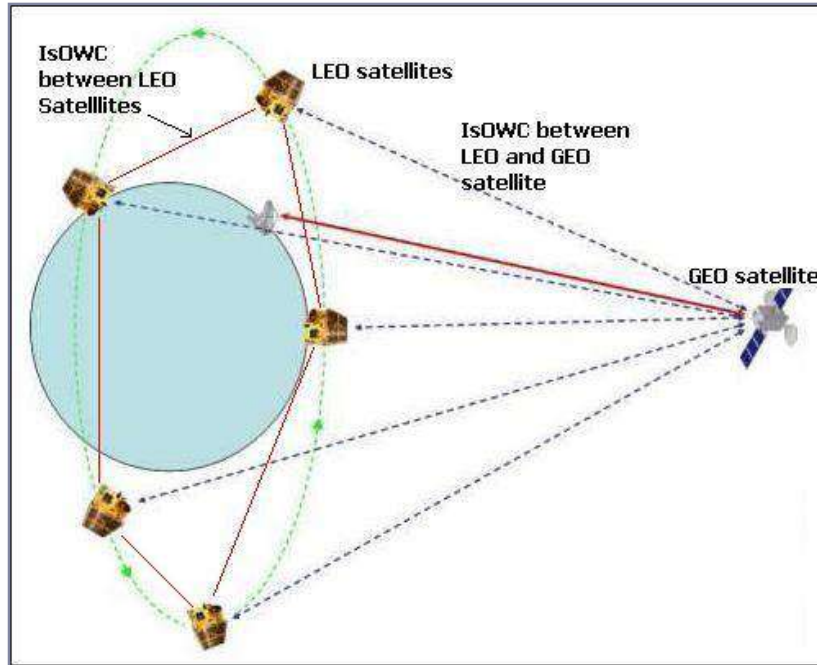
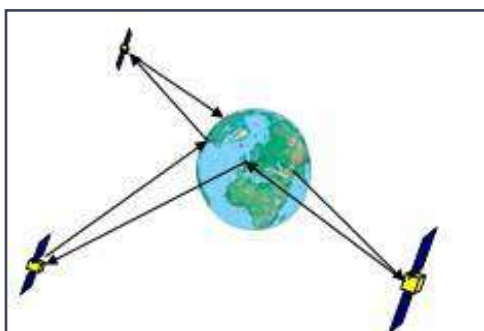
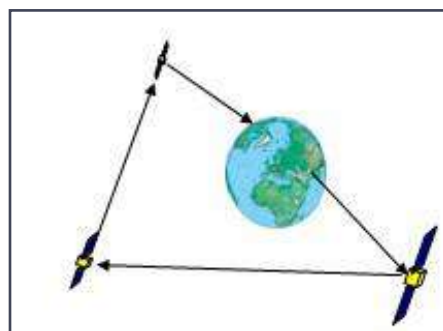

Figure 1.9 Is-OWC data relay concept for inter orbit

The data which is called relaying data by using inter satellite link can also reduce the time it takes to be sent data from one side of the world to another. In Figure 1.9 (a) shows the conventional way of relying data similarly relaying data using inter satellite link is shown in Figure 1.9 (b). [13] Transmitting data from Earth to satellite has high time delay; therefore by using Is-OWC, the time delay can be reduced.



(a)



(b)

Figure 1.10 (a) Data relay method by conventional method (b) data relay method using inter satellite method

## 1.5.2 Connecting Constellation of Satellite

It is necessary more than one satellites need to connect. Few applications and missions are required more than one satellite such as global tracking system (GPS) satellites and Iridium Satellite. To do this so, the most and fastest effective way to connect is by using inter satellite links. For example, the Iridium system has 66 satellites up in space at an altitude of 700km. These satellites are kept into 7000 km altitude in space by placing in 6 orbit. These satellites are to become the base stations for cellular mobile communication. Iridium satellites employ RF intersatellite links to connect with each other at Ka-band frequency. Due to the short distance between the satellites and low data rate, the intersatellite link is applicable. However, by using Is-OWC, the data rate can be improved and more mobile user can be supported. The constellation of satellites orbiting Earth is shown in the Figure 1.10.

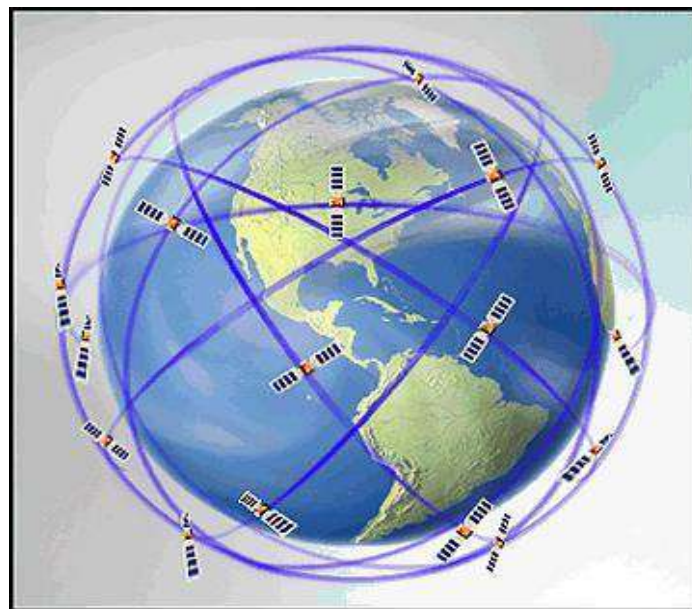

Figure 1.11 Satellite Earth Orbit Constellations

Starlink is a satellite constellation development project underway by American company Space X, to develop a low-cost, high-performance satellite bus and requisite customer ground transceivers to implement a new space-based Internet communication system. Space X also plans to sell satellites that use a satellite bus that may be used for military, scientific or exploratory purposes.

## 1.6 Related Research

Several researchers had written on the optical intersatellite link. Pfennigbauer and Leeb (2003) in their paper entitled Free-space Optical Quantum Key Distribution Using Intersatellite Links had presented the employment of quantum cryptography in intersatellite links [12]. The paper also discussed the link properties where attenuation, A, for intersatellite link and satellite to Earth link was calculated using the equation 1.7.

$$A = \frac{L^2(\theta_T^2 + \theta_{atm}^2)}{D_R^2} \frac{1}{T_T(1-L_P)T_R} 10^{A_{atm}/10} \dots\dots\dots (1.7)$$

where L is the distance between the transmitter and receiver,  $\lambda$  is the wavelength,  $\theta_{atm}$  is the atmospheric turbulence that causes divergence,  $D_R$  is the receiver's optical antenna diameter,  $L_P$  is the pointing loss,  $A_{atm}$  is the attenuation of the atmosphere,  $T_T$  and  $T_R$  are the transmission factors for the transmitter and the receiver respectively.  $\theta_T$  is the divergence angle at the transmitter where it can be given by  $\theta_T = \lambda/D_T$  and  $D_T$  is the diameter of the transmitter's optical antenna. Since the intersatellite link communication is not affected by the atmospheric turbulence and attenuation of the atmosphere, equation 2.3 can be reduced into

$$A = \frac{L^2\left(\frac{\lambda}{D_T}\right)^2}{D_R^2 T_R T_T (1-L_P)} \dots\dots\dots (1.8)$$

Similarly here, L = the distance between the transmitter and receiver,  $\lambda$  is the wavelength,  $D_R$  is the receiver's optical antenna diameter,  $D_T$  is the transmitter's optical antenna diameter,  $T_T$  and  $T_R$  are the transmission factors for the transmitter and the receiver respectively and  $L_P$  is the pointing loss.

Here we have seen from the calculation of the equation that, the results from calculations of attenuation for LEO-LEO and GEO-GEO intersatellite link were presented in the paper as shown in Figure 2.6 (a) and (b) respectively where  $D_T$  and  $D_R$  used is equal [12]. The paper concludes that for larger optical antennae are needed for longer transmission distance.

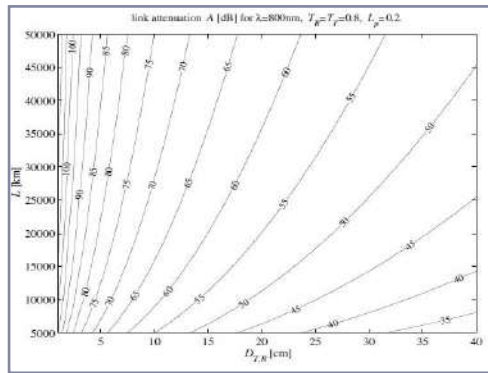
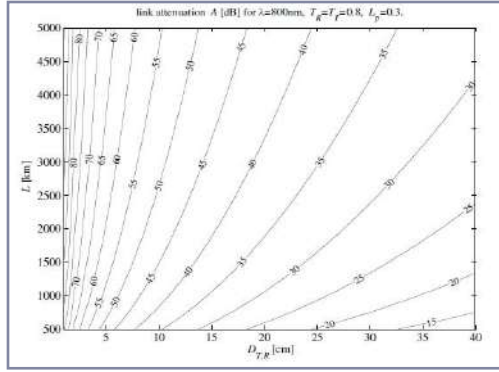

(b)

Figure 1.12 Link attenuation for (a) LEO-LEO link and (b) GEO-GEO link

Another relevant research is found in Chan (2003) in his paper Optical Satellite Networks [2]. In the paper, the author discussed the feasibility in constructing high speed optical satellite network as part of a larger integrated spaceterrestrial network. According to Chan, optical wireless intersatellite links can be used as a backbone for global networking creating local area networks and wide area networks all over Earth. The intersatellite links can also be connected to remote sensing satellites, airplanes, ships, submarines and spacecrafts far away from Earth. The usage of intersatellite link proposed in the paper is shown in Figure 1.12 [2].

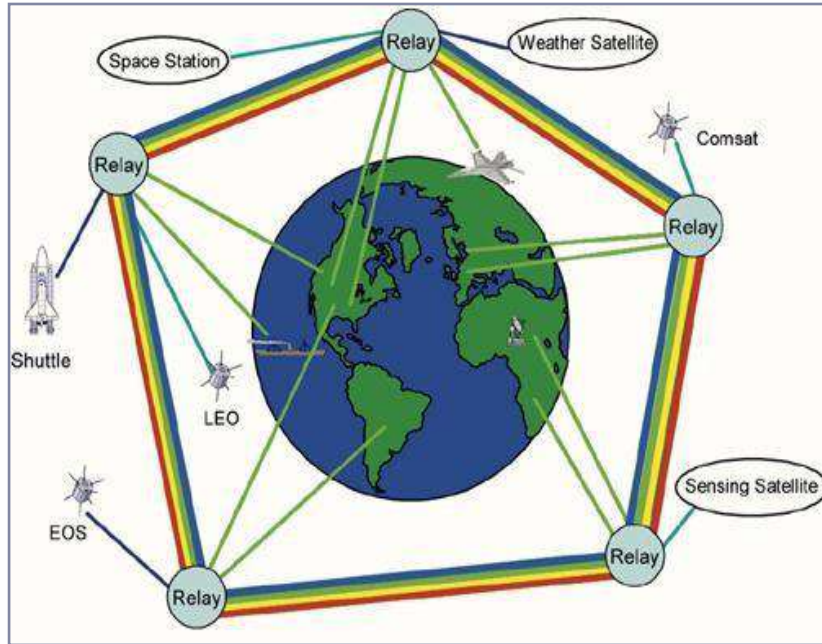

Figure 1.13 Optical satellite network creating a global connection

The paper also presents an advanced block diagram of an intersatellite optical transceiver as in Figure 1.13 [2]. The transceiver system includes tracking system and attitude control system to point the transceiver to the other satellite. The figure shows the high level optical satellite communication system where lots of the sub blocks are exists which determined the communication level is high and various important blocks are consists of in it such as mainly telescope, controller etc...

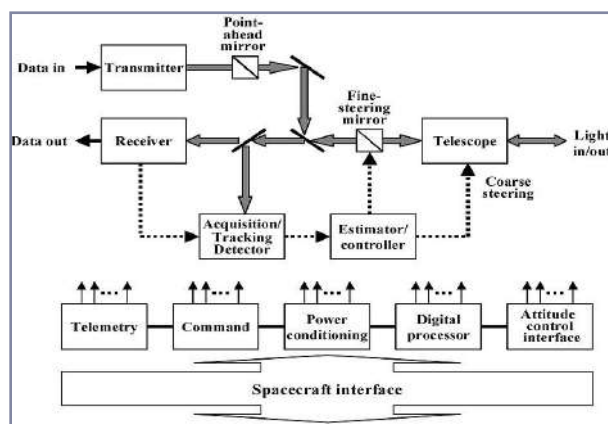

Figure 1.14 High-level optical intersatellite communication system

## 1.7 Project Objectives

The objectives of the project done are as follows:

- i) To know and study the inter satellite link OWC system.
- ii) To introduce the term OWC (Optical Wireless Channel).
- iii) To design and evaluate a high data rate Inter Satellite Optical Wireless Communication (ISoWC) for improved distance.
- iv) To analyze proposed work with existing in terms of Q factor, BER.

## 1.8 Scope of the Works

This project is contracted to some certain boundaries by following some specific guidelines in order to achieve these project objectives.

At first, the environment surrounding the satellites is assumed to be vacuum. We also know that the link of the inter satellite is aligned in the line of sight (LOS). For that reason, the concept of the inter satellite LOS is studied in this project. Also any object obstructed in its LOS sight is not studied in this project.

This project models basic optical communication system where no advanced modulation, multiplexing or coding technique is used. Is-OWC system that is designed and modelled layout in this project is done by the Optiwave OptiSystem Software. For that reason, the output results of the system rely upon the OptiSystem software characteristics and mainly upon OWC channel characteristics.

There are some parameters that can affect the system performance such as the distance between the transmitter and receiver, data bit rate, input power and wavelength. By varying there performance affective parameters, we analysed the system. In terms of bit error rate (BER), Quality factor, received power, the performance of the system is measured.

## **1.9 Problem Statement**

Today, in various significant areas, the artificial satellites are utilized for the purpose of communication to pass the signal with high data rate by covering enormous distance. Transmitting and receiving data in satellite communication using different types of wireless communication medium in radio frequency (RF) and microwave frequency form experiences various limitations like license requirement, fixed bandwidth, high cost and interference occurrence between signals. Hence, a new link named optical wireless communication (OWC) channel is developed to establish a medium between satellites termed as Inter-satellite Optical Wireless Communication (Is-OWC) system. The Systems of Is-OWC have demonstrated as a profitable toward lots of applications. The system has more advantages over presently being used microwave communication systems. Since optical link are able to transmit very high frequency which is up to 194 THz for wavelength 1550nm, therefore it can support high data rate transmission [5]. For intersatellite communications, signal need to travel thousands of kilometers from one satellite to another. If RF system is to be employed, the size of the transmitting and receiving antenna that is needed would be very big (about meters wide) and also heavy, compared to using optical link that would only need an optical antenna of several centimeters big. Reducing size and weight of the satellite's payload can reduce the cost of the satellite, which is what every satellite designer aims for.

## **1.10 Thesis Outline**

The project thesis consists of five chapters. These five chapters enclose to the final characteristics of the result and helps to the achievements of the objectives.

Chapter 01 eliminates the concepts of the basic satellites. It also introduces the basic concept of the OWC channel and inter satellite links developments which is the most contractive part of the Is-OWC system. Chapter 1 also discusses the steps taken and problem statement of the project.

In Chapter 2, the methodology of the project is presented and explained in details of each steps in the methodology. The chapter explains the process of this project from research study of

OWC and satellites to modeling, simulating, gathering results, analyzing and writing this thesis report.

Chapter 03 introduces the basic project methodology and system modelling of the proposed project. It also represents the steps taken as a method the design and developed the project objectives such as design procedure, opti system software concepts, system design components and system model in the software with its simulation and result analysis.

The findings of this project are presented in Chapter 4. The system performance is presented in graphs and figures and is then discussed. System performance is measured in Q-factor and the signal received power. The relationship of these parameters with varying input parameter such as bit rates and distance is conferred in this chapter.

The final chapter is Chapter 6 where the overall project is concluded. The chapter answers on whether the project objectives are successfully accomplished and then concludes the findings of this project. Lastly, some recommendations were stated on future work that can be continued and improved from this project.

## CHAPTER 02

### LITERARURE REVIEW

#### 2.1 Paper Review

In this section the works by other researchers that are related to this thesis “Design and Evaluation of 20Gbps Inter Satellite Optical Wireless Communication System for improved distance and performance” will be reviewed, which is vital element to successful research to the Is-OWC system which leads to the higher distance performance with better Q factor and minimum BER. Hence, for the design and simulation of the system we use amplifier in transmitter for higher distance performance.

1. Research paper on “Design and Evaluation of 10-Gbps Inter-satellite Optical Wireless Communication Link for Improved Performance”

Inter-satellite optical wireless communication (Is-OWC) systems can be chosen over existing microwave satellite systems for deploying in space in the future due to their high bandwidth, small size, light weight, low power and low cost. However, the Is-OWC system suffers from various attenuations due to weather conditions, turbulence or scintillations which limit its performance and decreases its availability. In this paper, the researchers designed an Is-OWC link for improved performance. So, in order to improve the performance, Is-OWC system using directly modulated laser source is proposed in this work. The system is designed and evaluated to be suitable for high data rate transmissions up to 10 Gbps. The performance of the system is investigated in order to reduce the cost and complexity of link and improving the quality of information signal. Further the proposed Is-OWC system is analysed using BER analyser, power meter and oscilloscope Visualizer. [1]

2. Research paper on “Evaluation and Investigation of Inter-satellite Optical Wireless Communication System for Different Optical Windows in Medium Earth Orbit”

In this paper reveals the design and simulation analysis of  $45 \times 20$  Gbps Dense Wavelength Division Multiplexing (DWDM) Inter-satellite Optical Wireless Communication (IsOWC) System by taking into account the concept of reduced channel spacing of 50 GHz for different optical windows. The high capacity system is proposed and its performance analysis is observed for various parameters like transmission range and input power. Moreover, the role of EDFA is noteworthy which does the task of amplification efficiently and made the system to work over a transmission range of 12500 km with acceptable Q-Factor and BER in different optical windows such as 850 nm, 1310 nm, 1550 nm and 1620 nm window. It is seen the C band performs best and L band worst in terms of Q factor and BER. [2]

3. Research paper on “Inter-satellite Optical Wireless Communication System Design using Diversity Techniquewith Filter and Amplifier ”

In this paper, designed a high speedcommunication system for inter-satellite using space andpolarization diversity using filter and amplifier. Here consideredlink distance is 7000 km and by simulation we analyze achievablebit rate 40Gbps. The Q factor, eye opening and BER has improved from previously proposed system. This proposedsystem can be used for higher data rate in communicationbetween satellites. [3]

4. Research paper on “DPSK and Manchester coding for Inter-satellite Optical Wireless Communication systems”

In this paper, proposed an Is-OWC system which uses DPSK modulation with Manchester coding. The performance of the system is analyzed for with Manchester and without Manchester coding. Manchester coding provides self-synchronization of the transmitted bits. Thus performs better compared to the system without Manchester coding. The system will be very much useful for high speed communication applications among satellites. [4]

5. Research paper on “Performance Analysis of Inter-Satellite Optical Wireless Communication (Is-OWC) System by using Channel Diversity Technique”

In this paper, researchers used channel diversity technique which gives better result compared to single channel. Diversity technique in Is-OWC system provide multiple path to signal which help to increase the Q-factor and signal strength at large distance. Here, we have analyzed the designing and simulation of Is-OWC system by using OPTISYSTEM 7.0 software. The system is used multiple OWC channels at 40 Gbps data rate with distance range of 5000 km and pointing error of 1.1  $\mu$ rad and result shown in the form of BER, quality factor and eye diagram. [5]

6. Research paper on “Q-factor and BER Performance Analysis of Intersatellite Optical Wireless Communication Using 26 Transponders”

In this paper, the researchers proposed the communication system using 26 transponders are simulated using Optisystem software. The results of Q-factor, Bit Error Rate (BER) and threshold were measured and analyzed for all scenarios in order to optimize IsOWC of 26 transponders performance. [6]

7. Research paper on “Optimizing Different Parameters of Inter-Satellite Optical Wireless Communication (Is-OWC) System by Incorporating Mach Zehnder Interferometer (MZI) with Duobinary Modulation Technique”

In this paper, High speed data transmission for long distance is the main motive of today's as well as for next generation communication system. Inter-satellite communication provides the superior result with Optical Wireless Communication (OWC) technology. Duobinary encoding technique provides the highly efficient result for long distance communication with data security. In this paper, we designed a system to communicate two or more satellites using Duobinary modulation technique with Mach Zehnder Interferometer (MZI). The performance of system is analyzed by OPTISYSTEM 7.0 software for bit rate up to 100 Gbps for 8000-kilometer distance with transmitting

power of 20 dBm and result shown in the form of BER, Q-factor and eye diagram obtained. [7]

8. Research paper on “To Design High Speed and Long Reach Inter-Satellite Communication System by Incorporating Orthogonal Frequency Division Multiplexing Scheme”

In this paper, investigated the performance of an Inter-Satellite Optical Wireless Communication (ISOWC) system with Orthogonal Frequency Division Multiplexing (OFDM) using Quadrature modulation. The high capacity 10 Gbps data traffic is successfully transmitted using a 4-level Quadrature Amplitude modulated sequence through the ISOWC system without space turbulence's. We have observed that by using semiconductor optical amplifier, 10 GBPS data stream has been successfully transmitted to 15000 km with an acceptable SNR. [8]

9. Research paper on “Analysis of pointing error at 100Gbs by using different encoding technique in Spatial Diversity based Is-OWC Communication System”

In this paper, we have designed and simulate the Is-OWC system by using 16 OWC (16x16 Tx and Rx antenna) channels at different encoding technique. Due to spatial diversity signal have more than one path to travel from one point to another end by using fork 1: N at high data rate up to 100 Gbps and 10000 Km distance range. In the proposed designing, we analysed the Is-OWC system with NRZ, AMI, Duobinary encoding technique. The main motive of the system to judge the various types of encoding technique with superior result at large distance coverage with minimum value of BER. Among the three-encoding technique Duobinary signal gives best result at different degrading factors like pointing error up to 3 $\mu$ rad at 20 dBm power level by using OPTISYSTEM 15.0 software. The result expressed in form of Q-factor and BER. [9]

10. Research paper on “Design of a Standardized Inter Satellite Optical Wireless Communication (IsOWC) System with Minimum Input Power”

In this paper, proposes a novel method for low power communication between two Low Earth Orbiting satellites. The IsOWC system is designed for minimum input power of 27.02 dBm and -7.6 dBm, at 2.5Gbps. A standardized system for a distance of 5000 km and wavelength 1550 nm is designed and its performance is analysed by varying the modulation schemes and filters. A Square root (SQRT) transfer function module (SRM) is used to compensate the square-law characteristic of the photodiode. By using SRM in the system 67% increment in system efficiency is observed. The optimized performance is obtained by using NRZ scheme and Bessel filter. Highest Q factor of 6.70 dB and 6.72 dB are obtained for simulation with NRZ scheme and Bessel filter respectively, with minimum BER 10<sup>-12</sup>. [10]

11. Research paper on “Inter-satellite optical wireless communication system design and simulation”

In this paper, proposes an ultra-high bit-rate inter-satellite optical wireless communication (IsOWC) system is proposed in this study. The system is designed and simulated up to the bit-rate of 400 Gbps. The proposed system is a non-diffused link or line-of-sight setup, which uses coherent optical quadrature phase-shift keying (QPSK) modulation technique. The performance of the system is analysed in terms of Q-factor, bit-error rate, eye opening and so on. The coverage distance observed with an input power level of 30 dBm for a bit-rate of 400, 160 and 100 Gbps are 4767, 7542 and 9532 km, respectively. Finally, the maximum bit-rate that can be communicated, for inter-satellite link at different orbits such as low-Earth orbit, medium-Earth orbit and geostationary Earth orbit are presented. To the best of the authors knowledge for the first time they have proposed a novel QPSK modulation technique for the design of IsOWC system for achieving higher coverage distance and data rate, which was not been addressed in any current or earlier publications. [12]

12. Research paper on “INTER-SATELLITE OPTICAL WIRELESS COMMUNICATION SYSTEM DESIGN AND SIMULATION”

In this research paper, The mobile satellite communications systems of next generation will provide high-quality and flexible multimedia services to users at anywhere and at any time [1]. Communication between any two places in earth is an attractive goal. One of the feasible solutions to achieve this goal is networking the satellites together with the earth stations. Especially when the communication is required between two places, which are opposite to each other of the globe, then the information should be transmitted through the nearby satellite, the satellite then sends the information to its nearby satellite and so on. By virtue of this inter-linking process the group of satellites transmits the information down to the ground destination station. Thus inter-satellite link (ISL) plays an important role for the communication purpose for global coverage. These satellites should have high speed switching and processing capabilities. This system is complicated and made up of many units. The traditional Geostationary Earth Orbit (GEO) satellites are not suitable for this purpose because, they have i) high propagation loss; ii) large transmission delay. Instead of this kind of satellites, the Low Earth Orbit (LEO) and Medium Earth Orbit (MEO) satellites are highly suitable for the global coverage and communication purpose. Teledesic, Sativod, Celestri, Sky-bridge and M-star systems are few of the examples [2]. ISL using optical link has many advantage comparing to microwave link such as i) higher band width; ii) lower transmission power; iii) smaller size and weight of the terminals; iv) higher immunity to interference etc. All of these reasons are vital for a satellite communication system, because it can reduce the payloads and consequently reduce the costs. But due to small beam divergence, pointing, acquisition and tracking are more critical in optical link. The required tracking accuracy is typically on the order of  $1 \mu\text{rad}$  [3]. This requires closed-loop tracking, which is the only disadvantage of the system. This can be taken care by using servo-motors, which locks the beacon signals of the satellites [4] [5]. The proposed inter-satellite optical wireless communication (IsOWC) system uses lasers as a signal carrier. This is the key technology for realizing an ultra-high speed and long-haul communication system. The coverage distance of the IsOWC system depends upon many parameters such as type of modulation used, input power, operating wavelength, receiver sensitivity etc. Hashim et. al. proved that among all ON-OFF keying techniques non-return-to-zero (NRZ) is the best scheme, for obtaining maximum coverage distance of the link [6].

Comparing to ON-OFF keying techniques phase shift keying (PSK) technique is preferable for free space optical communication, as it does not require any adaptive thresholding method [7] [8]. Sodnik et. al. used binary phase shift keying (BPSK) modulation technique for inter-satellite link [9]. In this paper, we have used coherent optical quadrature phase shift keying (QPSK) technique, as it is spectrally more efficient than BPSK technique [10]. The proposed system is designed and simulated up to the bit-rate of 400 Gbps. The system is a nondiffused link or line of sight setup, which uses coherent optical quadrature phase shift keying modulation technique. The performance of the system is analyzed in terms of Q-factor, bit error rate, eye opening etc. The coverage distance observed with an input power level of 30 dBm for a bit-rate of 400 Gbps, 160 Gbps and 100 Gbps are 4,767 km, 7542 km and 9532 km respectively. Finally, the maximum bit-rate that can be communicated, for inter-satellite link at different orbits such as LEO, MEO and GEO are also presented. [12]

13. Research paper on “Free Space Optical Communication: Laser sources, Modulation Schemes and Detection Techniques ”

In this paper, the researcher proposes free space optical (FSO) communication is an upgraded supplement to existing wireless technologies. FSO technology leads vast modulation bandwidth, unlicensed spectrum, cost effective deployment, quick redeploy and much more. FSO systems are used to transmit and receive all kind of data at high data rates (up to 100 Gbps). Today researchers are preliminary focused to use the free space communication systems to make their inter satellites links. This paper gives a review on the laser diodes, modulation schemes and the detection techniques which are deployed in the FSO systems. [13]

14. Research Paper on “Challenging Issues in Inter-Satellite Optical Wireless Systems (Is-OWC) and its Mitigation Techniques”

In this paper, Inter-satellite optical wireless communication system (IsOWC), one of the important applications of FSO (Free Space Optics) technology, will be deployed in space in the near future because of providing power efficient and high bandwidth allocation facilities unlike present microwave satellite systems. In this paper, we have deliberated a presentation of different challenging issues in achieving a prolonged inter satellite link for an IsOWC system under different situations and conditions. This work is also emphasized on the suggested techniques to combat with the degrading factors to put into practice of high speed IsOWC system with minimum BER. Index Terms— Inter-satellite optical wireless system (IsOWC), BER, SNR. [14]

15. Research Paper on “Design of a Standardized Inter Satellite Optical Wireless Communication (IsOWC) System with Minimum Input Power”

In this paper, This paper proposes a novel method for low power communication between two Low Earth Orbiting satellites. The IsOWC system is designed for minimum input power of 27.02 dBm and -7.6 dBm, at 2.5Gbps. A standardized system for a distance of 5000km and wavelength 1550nm is designed and its performance is analysed by varying the modulation schemes and filters. A Square root (SQRT) transfer function module (SRm) is used to compensate the square-law characteristic of the photodiode. By using SRm in the system 67% increment in system efficiency is observed. The optimized performance is obtained by using NRZ scheme and Bessel filter. Highest Q factor of 6.70dB and 6.72dB are obtained for simulation with NRZ scheme and Bessel filter respectively, with minimum BER  $10^{-12}$ . [15]

16. Research Paper on “Optimization of inter-satellite link (ISL) in hybrid OFDM-IsOWC transmission system”

In this project, Inter-satellite optical wireless communication system (IsOWC), one of the important applications of FSO (Free Space Optics) technology, will be deployed in space in the near future because of providing power efficient and high bandwidth allocation facilities unlike present microwave satellite systems. In this paper, we have deliberated a

novel model of OFDM-IsOWC system using OPTISYSTEM™ simulator to optimize an inter-satellite link (ISL) between satellites with acceptable SNR and BER, which is not reported in previous investigated work. [16]

17. Research Paper on “PERFORMANCE ENHANCEMENT OF AN INTER SATELLITE OPTICAL WIRELESS COMMUNICATION LINK BY EMPLOYING VARIOUS MODULATION TECHNIQUES”

In this paper, we have designed an inter-satellite optical wireless communication (IsOWC) scheme using various modulation formats. The prospective model explains 32-channel dense wavelength division multiplexing (DWDM) with various modulation techniques as transmitters to the system. The link has been executed at different distance and external modulation of quadrature phase shift keying (QPSK), carrier-suppressed return-to-zero (CSRZ), duobinary return-to-zero (DRZ) and quadrature amplitude modulation (QAM) at variant bit rate. The performance is analyzed based on maximum quality (Q-factor) factor, minimum bit error rate (BER) and eye-diagram at different distance and bitrate. [18]

# **CHAPTER 03**

## **PROJECT METHODOLOGY AND SYSTEM MODELLING**

### **3.1 Introduction**

The steps by steps of the methodology are taken in order to achieve or reach the project objectives. The chapter 03 represents steps are taken to reach or fulfil the project where several steps were to be completed or accomplished. The flow chart diagram of the steps taken for the project is shown in the figure 3.1. The design of the Is-OWC system is discussed in this chapter. The software which is used to designed the system namely OptiSystem Software is also named here in the flow chart. Finally the system is designed and simulated and explains every of the subsystems of the design.

Step 01: We get started the work by taking a topic from our supervisor.

Step 02: We studied related to topic and studied mainly Optical Wireless Channel Model (OWC model).

Step 03: We studied related to topic and studied mainly intersatellite link Model (ISL model).

Step 04: Then we designed the required IsOWC model related to topic.

Step 05: We have seen the required model and if it is not OK we have gone to again steps 1,2,3 and 4.

Step 06: When the design model was OK, we have get stepped to Simulation of Model.

Step 07: Analysed the results.

Step 08: Written Thesis Book.

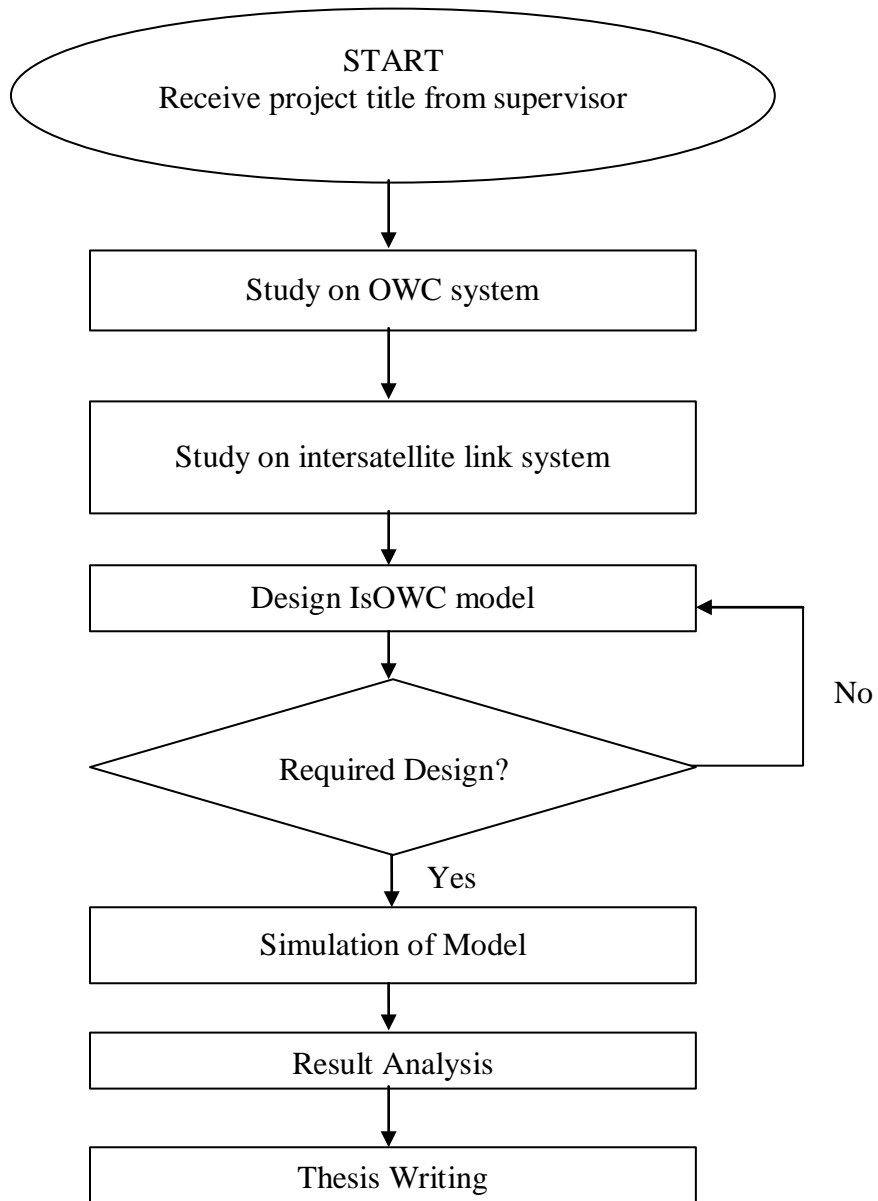

**Figure 3.1** The project methodology

### 3.1.1 Study on OWC System

This first step is important in order to understand what the project is all about. This is also important in order to achieve the first objective of the project which is to study OWC for intersatellite links. The research sources are mainly from books, library and online databases of previous researches.

### **3.1.2 Study on Intersatellite Link System**

The second step is to study about the satellites and intersatellite links. It is important to know how satellite works and what IsOWC will achieve in connecting the satellites. The basic theories about satellite were learned in class, but books and previous researches provide extra information on the topic. There are not many existing intersatellite links, therefore to find a relevant paper on this topic is hard. Therefore, the most relevant experiment relevant of this project is from the Artemis and Kirari optical intersatellite link.

### **3.1.3 Design the IsOWC Basic System Model**

The second objective of this project is to design the IsOWC system model. This is done by using Optiwave's OptiSystem software. It took several days to study the software and to get used to it. Several designs were built to get an optimum design. The first design consists of basic OWC communication subsystems which are optical transmitter, OWC channel and optical receiver. The design was then improved by building the optical transmitter and receiver block by block.

### **3.1.4 IsOWC System Simulation of Model for Characteristics Performance**

Using the model designed in OptiSystem, parameters such as bit rate, distance between satellites and power were varied to study the system's performance. Further study on the software was done at this step to understand the visualizers to be used to analyze the output of the system. The visualizer that is most important in this design is the BER Analyzer where the system BER, Q-factor and eye diagram were obtained from it. Apart from that, the relationship between optical antennae diameter, attenuation, and receives power were plotted using Microsoft Excel. The result of the plot shows the advantage of using optical antennae where the received power improved as the antennae diameter increased.

### **3.1.5 Result Analysis**

From the simulation results, analyses were made to see the system performance. Graphs were plotted to have a clearer view on the system's performance. Observations were then made from the graphs and conclusions were drawn from it. The results were compared with previous researches and the theory to prove its validity.

### **3.1.6 Presentation and Thesis Writing**

After the conclusions were drawn, the project is considered complete. The final step to be taken is to present the project and to write the thesis. This step is done as the requirements in completing the course.

### **3.1.7 Conclusions**

In this chapter, the steps and methodology of this project were presented and discussed. The steps were done in order to achieve what the project aims for. At the end, everything there is to know about this project is written in the thesis.

## **3.2 Opti system software**

The OptiSystem software is developed by Optiwave to perform complex optical communication simulation. It provides an easy user interface which is common to many other electrical engineering tools. The OptiSystem software is suitable to be used to model and simulate fiber optic system, free space optic system and also OWC system. The OWC channel provided in the software is specifically designed to suit the intersatellite environment.

## **3.3 System Design Components**

This section identifies the required components and sub systems to design and be efficient of the proposed designed system.

### 3.3.1 Is-OWC Transmitter Design

The Is-OWC transmitter system design consists of four sub systems. Among these, the first subsystem is the pseudo-random bit sequence generator which is to represents the information or data to be transmitted. The data usually come from the satellite's TT&C system. Here in this project, the data is kept 20Gbps is have seen how that data is sent efficiently for the higher distance.

The subsystem is used as a second is called RZ pulse modulator. The RZ pulse modulator sub system encodes the data come from the pseudo-random bit sequence generator using the return zero encoding technique. Figure 3.2 shows the RZ encoding technique.

Return-to-zero (RZ or RTZ) describes a line code used in telecommunications signals in which the signal drops (returns) to zero between each pulse. This takes place even if a number of consecutive 0s or 1s occur in the signal. The signal is self-clocking. This means that a separate clock does not need to be sent alongside the signal, but suffers from using twice the bandwidth to achieve the same data-rate as compared to non-return-to-zero format.

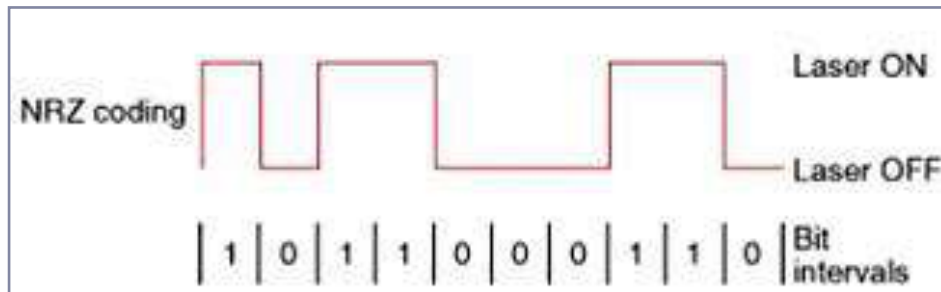

**Figure 3.2** RZ encoding technique

The third subsystem in the Is-OWC transmitter design inside satellite 01 is the Continuous Wave (CW) laser where the output signal of the laser is nonstop and unmodulated. Lasers are used instead of LED for this system because of its ability to transmit at further distance. The frequency of the light is chosen to be 1550nm or 193.1THz with input power of 10dBm. These parameters can be change and the effect of varying the frequency is discussed in the next chapter.

The last subsystem in the transmitter is the Mach-Zehnder Modulator. It is an optical modulator that functions is to vary intensity of the light source from the laser according to the output of the NRZ pulse generator. The Mach-Zehnder modulator consists of two couplers and two waveguides of equal-length as shown in Figure 3.3. The input optical signal from the laser will split in to two and go through phase shifting process in the waveguides. Phase-shifting happens due to the electro-optic effect where the output electrical pulse from the NRZ pulse generator will vary the voltage hence varying the refractive indices of the waveguides. The output of the Mach-Zehnder modulator will be transmitted to the other satellite through the space of OWC channel.

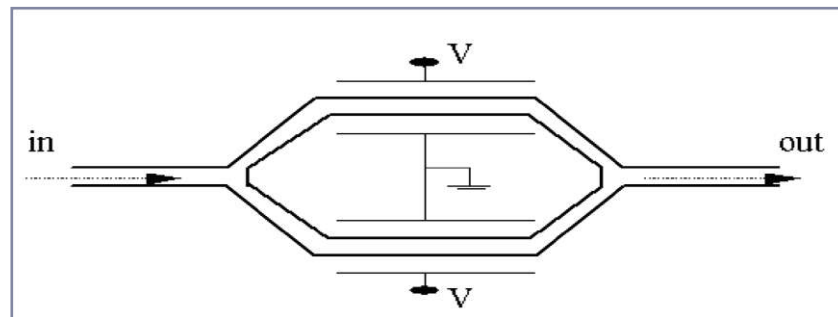

Figure 3.3 Mach-Zehnder Modulator varies the light intensity according to voltage

### 3.3.2 OWC Channel

In Is-OWC system, the free space which exists between two connecting satellites is called Optical Wireless Channel (OWC) channel. OWC channel is used in it as it is the propagation medium between the optical transmitter and receiver which transmit the transmitted light from the Is-OWC transmitter design. The OWC channel is spaced 15 cm optical antenna at each end between transmitter and receiver in Is-OWC system. The gain of the transmitter and receiver are 0 dB. The antennae of the transmitter and receiver are considered to be an ideal where the optical efficiency is equal to one and there are no pointing errors. There is no attenuation due to atmospheric effects and due to the altitude of the satellites that is above the Earth's atmosphere. Additional losses from scintillation and mispointing are also assumed to be zero.

### 3.3.3 Is-OWC Receiver Design

The Is-OWC receiver system have three main subsystems such as Avalanche Photo Diode (APD), Low pass filter and 3R generator. The photodiode acts as a front-end receiver that receives the optical signal and converts it into electrical signal. The APD photodiode has an internal gain which allows for the reduction of noisy external amplifiers in optical detection systems. Therefore, in this system model, no optical amplifier is needed. Apart from that, the APD photodiode is useful in low, weak or reduced light applications because of the avalanche phenomenon utilized by the device provides high amplification. Hence it is ideal to be used in this system where the long distance transmission reduces the intensity of the light. APD photodiode used in the OptiSystem model has a multiplication factor of 3 and default dark current used is 10nA. The frequency of the photodiode is set to 193.1THz.

The low pass filters (LPF) after the photodiode is used to filter out the unwanted higher frequency signals. Bessel LPF is used with cut-off frequency of  $0.75 \times$  bit rate of the signal. The order of the Bessel function is 4 and the maximum attenuation of the filter is 100dB. The 3R regenerator is the subsystem use to regenerate electrical signal of the original bit sequence, and the modulated electrical signal as in the transmitter to be used for BER analysis. It is as if the BER analyzer is connected to the output of the pseudo-random bit sequence generator and NRZ pulse generator in the transmitter to be compared with the received signal at the LPF output. Figure 3.4 shows an example of connection of the BER analyzer without 3R regenerator.

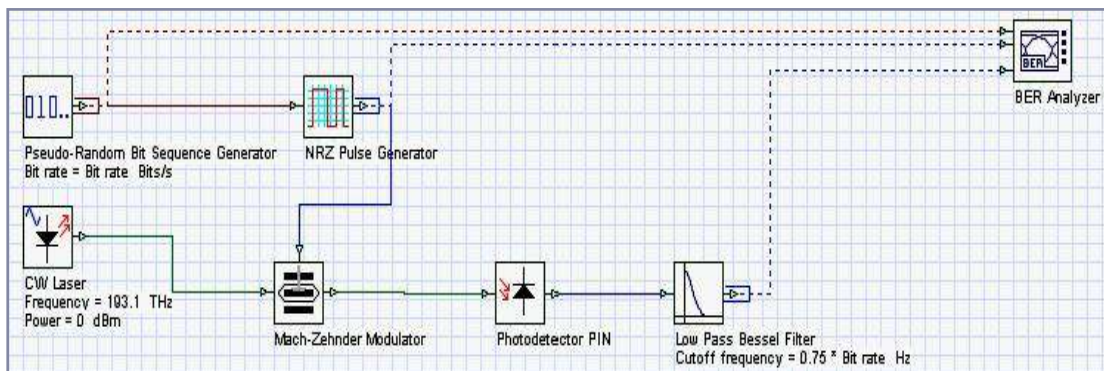
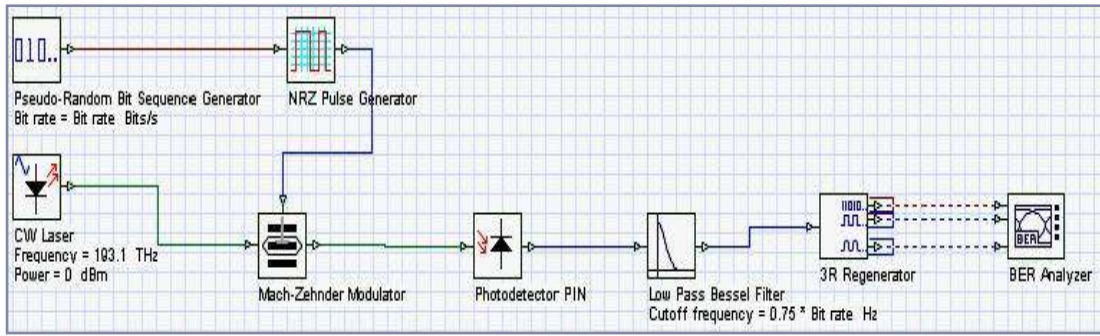

Figure 3.4 BER analyzer is connected to the transmitter when without 3R regenerator

The basic block diagram of Is-OWC diagram is shown in Figure 3.4. In our proposed system, the first subsystem is the transmitter part which consists of PRBS generator. It generates the data which is to be transmitted i.e. data source. The second subsystem represents the different modulation formats which get its output from the previous block. This subsystem encodes the data from PRBS output by (CSRZ, DRZ and DPSK) techniques. The third subsystem is DML i.e. directly modulate laser which operates on wavelength of 1552 nm because of low attenuation characteristics in optical communication in this wavelength region.

The free space between transmitter and receiver is considered as OWC channel which is the propagating medium for the transmitted optical signal. The optical receiver comprises of a photo detector followed by a low pass Bessel filter. In this section of system, the optical signal is converted back into electrical signal. APD (avalanche photo-diode) is used because of its high gain property. The last subsystem is BER tester which gives the Quality factor and BER measurement.



**Figure 3.5** Connection of the BER analyzer to the 3R regenerator

Figure 3.5 shows the connection with 3R regenerator. Note the result of the connection is equivalent. The output of the 3R regenerator is connected to the satellite’s TT&C system for further signal processing.

### 3.4 System Model in OptiSystem

Several designs were built to obtain the optimum design for the IsOWC system. Based on the basic Is-OWC block diagram presented in Chapter 2, the system is modeled with basic communication subsystems as stated in the project’s scope of work. The first design consists of basic OWC communication system and is shown in Figure 3.6. The design was then improved by expanding the optical transmitter and receiver with specific subsystems. This is shown in Figure 3.7.

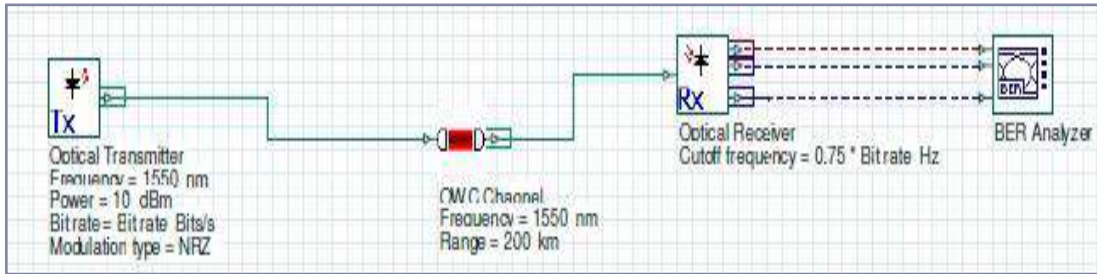

Figure 3.6 Is-OWC first designs with basic subsystems

The basic block diagram of Is-OWC diagram is shown in Figure 3.6. In our proposed system, the first subsystem is the transmitter part with Frequency 1550 nm and modulation type NRZ. The free space between transmitter and receiver is considered as OWC channel which is the propagating medium for the transmitted optical signal. The optical receiver is connected with BER analyzer which defines the signal strength from optical transmitter through the optical OWC channel.

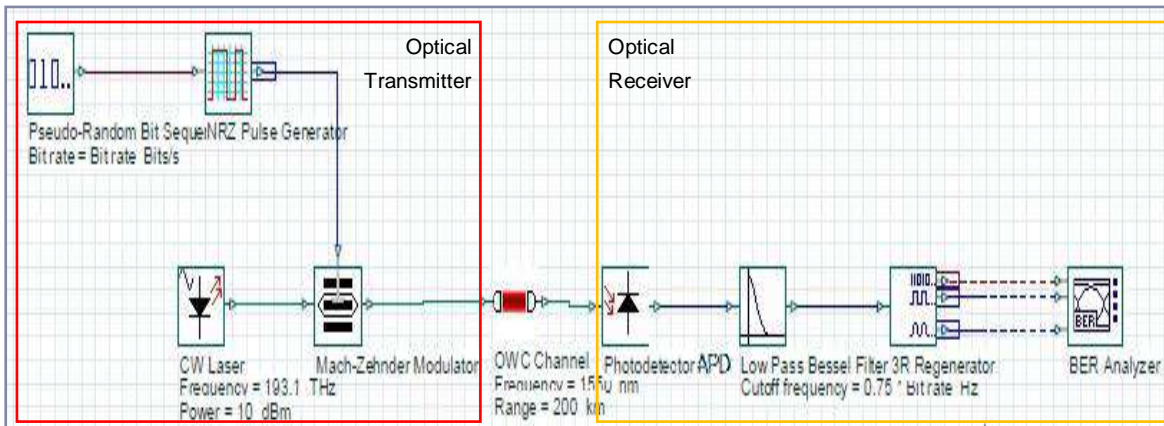

Figure 3.7 Is-OWC first designs with basic subsystems (simpler design)

The first subsystem of Figure 3.7 is the transmitter part which consists of PRBS generator. It generates the data which is to be transmitted i.e. data source. The second subsystem represents the different modulation formats which get its output from the previous block. This subsystem encodes the data from PRBS output by respective modulation techniques. The third subsystem is

DML i.e. directly modulate laser which operates on wavelength of 1552 nm because of low attenuation characteristics in optical communication in this wavelength region.

The free space between transmitter and receiver is considered as OWC channel which is the propagating medium for the transmitted optical signal. The optical receiver comprises of a photo detector followed by a low pass Bessel filter. In this section of system, the optical signal is converted back into electrical signal. APD (avalanche photo-diode) is used because of its high gain property. The last subsystem is BER tester which gives the Quality factor and BER measurement.

In this paper, Is-OWC system has been designed using RZ modulation and Optical amplifier. The proposed design system which consists of transmitter where binary sequence is produced and is passed through the OWC channel between two satellites using CW laser beam.

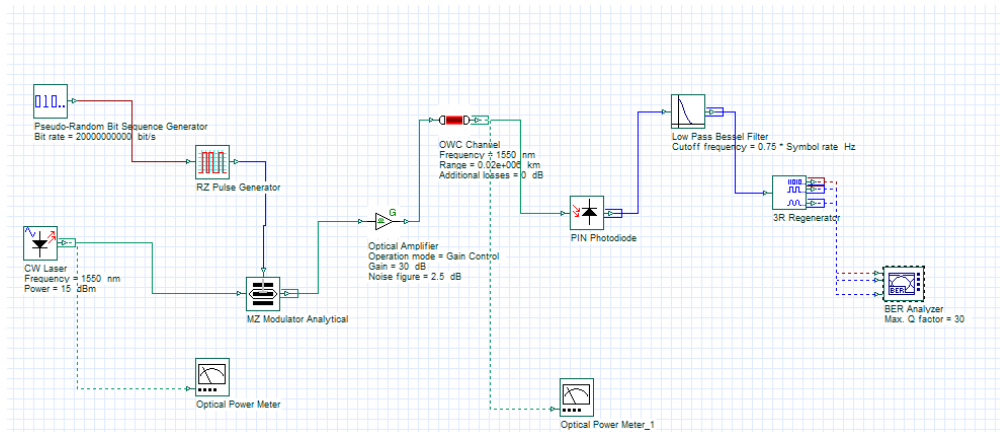

Figure 3.8 Is-OWC designs with amplifier for higher distances

As shown in Figure 3.8, the proposed system is designed using similar basic process of Is-OWC design with Optical transmitter, OWC channel and Optical receiver. Here, we used optical amplifier in transmitter part and RZ modulation technique to robust the the trsnmitted signal and can propagate through the higher distance which is the main challenges issues in Is-OWC system.

### **3.5 Result Analysis**

From the simulation results, analyses were made to see the system performance. Graphs were plotted to have a clearer view on the system's performance. Observations were then made from the graphs and conclusions were drawn from it. The results were compared with previous researches and the theory to prove its validity.

### **3.6 Presentation and Thesis Writing**

After the conclusions were drawn, the project is considered complete. The final step to be taken is to present the project and to write the thesis. This step is done as the requirements in completing the course.

### **3.7 Conclusion**

In this chapter, the steps and methodology of this project were presented and discussed. The steps were done in order to achieve what the project aims for.

# CHAPTER 04

## RESULT ANALYSIS

### 4.1 Introduction

The Is-OWC system is designed and modelled using OptiSystem Software by characterizing the performance parameters. The designed system is varied various parameters to obtain the optimum results of the designed model and also to achieve the efficient system performance of the model. The results from the simulation have been seen and interpreted using project browser, power meter and eye diagram analyser. The opening eye diagram resulted for a distance 20,000 km .Furthermore, other OWC link performance characteristics were also in considered which includes the system bit rate, the frequency of light carrier signal of CW laser and the optical receiver sensitivity. From the simulation, two observation was done which is the relationship of the Q-factor and the bit rate at varying distance and also the relationship between Q-factor and the signal wavelength.

### 4.2 Q factor Curve using optical amplifier

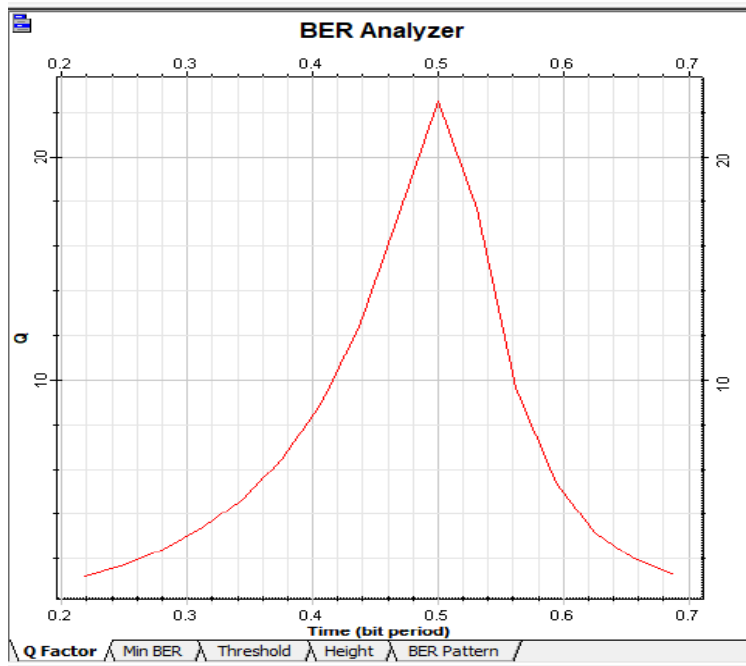

Figure 4.1 Q factor Curve using optical amplifier

The quality factor (Q-factor) curve in Figure 04 obtained using optical amplifier instead of various multiplexing technique in order to increase link distance. It is seen that an increased value of Q factor has gained to 23 that is an optimum value for long distance efficient communication.

Figure 06 shows the BER pattern with eye diagram which defines the lowest bit error rate. The pattern clearly shows that an open eye diagram is obtained having an eye height of 98, threshold value of 21.5 and a decision inst. of 0.5303 is attained.

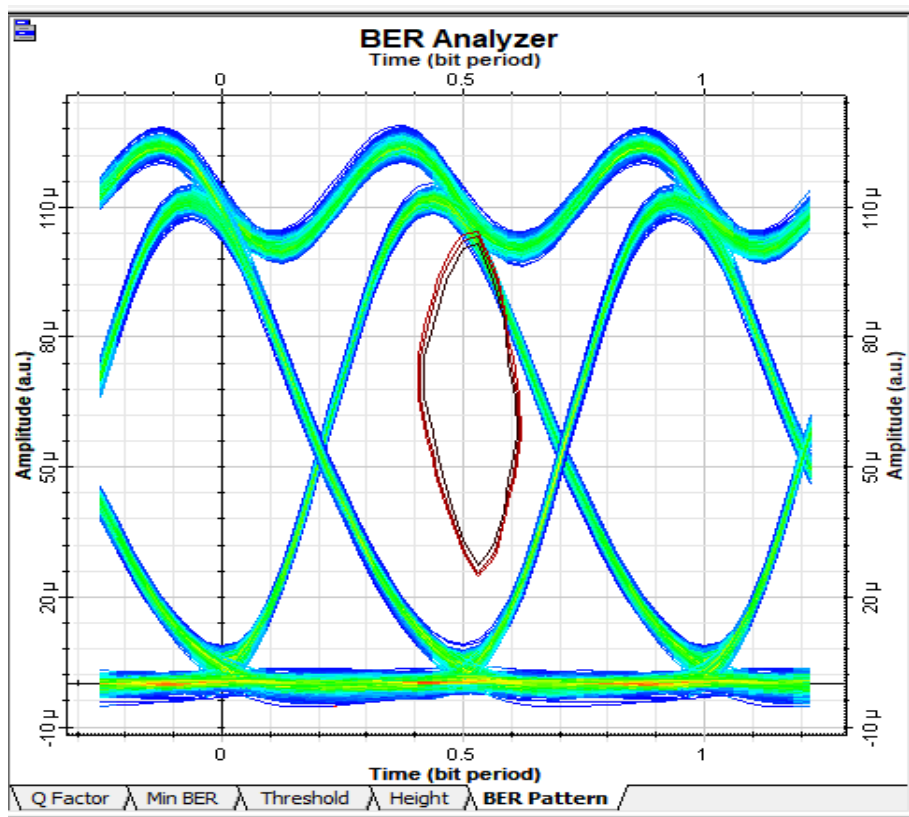

Figure 4.2 BER Pattern

The results from the simulation have been seen and interpreted using project browser, power meter and eye diagram analyser. The opening eye diagram resulted for a distance 20,000 km as shown in Figure 4.3. It is also seen from the eye diagram analyser that it shown the wide eye opening with an eye height of  $7.67863e-113$  and threshold of  $5.54501e - 005$ . For the referred

transmission distance 20,000 km, the proposed system gives a reduced bit error rate (BER) value  $7.67863 \times 10^{-5}$  and data rate up-to 20Gbps which demonstrates the ideal performance of link for a long-range communication link in Figure 4.4.

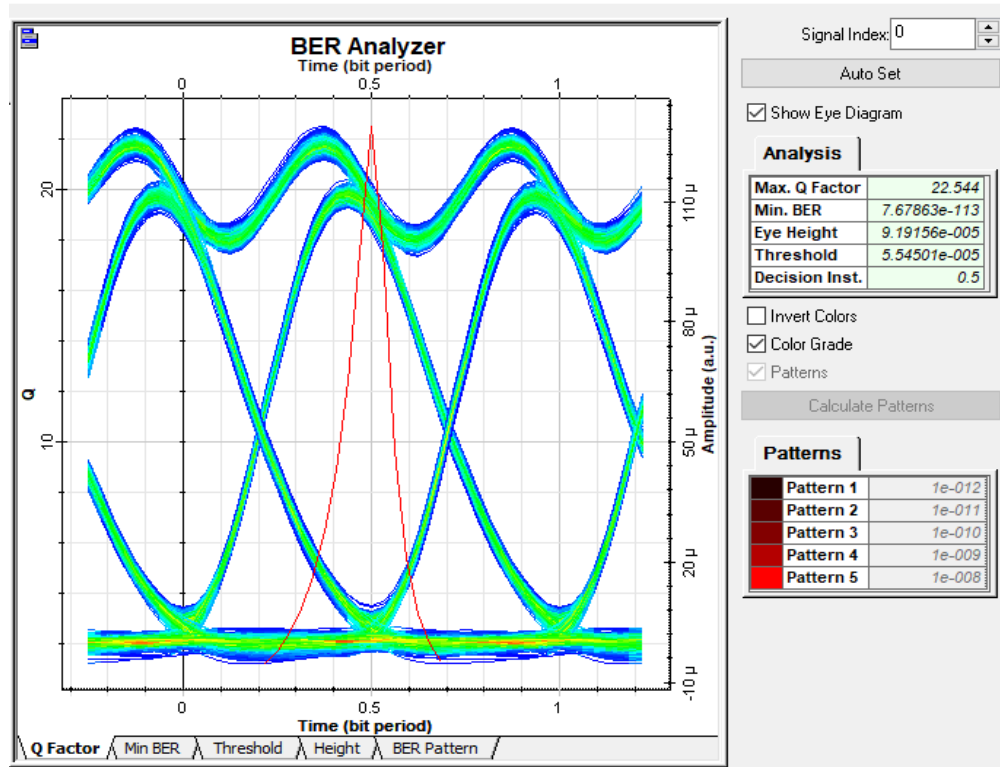

Figure 4.3 Eye Diagram output using CW laser

An eye pattern, also known as an eye diagram, It is a tool for the evaluation of the combined effects of channel noise and intersymbol interference on the performance of a baseband pulse-transmission system. It is the synchronised superposition of all possible realisations of the signal of interest viewed within a particular signaling interval. It is so called because, for several types of coding, the pattern looks like a series of eyes between a pair of rails.

Several system performance measures can be derived by analyzing the display. If the signals are too long, too short, poorly synchronized with the system clock, too high, too low, too noisy, or too slow to change, or have too much undershoot or overshoot, this can be observed from the eye diagram. An open eye pattern corresponds to minimal signal distortion. Distortion of the signal waveform due to intersymbol interference and noise appears as closure of the eye pattern.

Hence from Figure 4.3, we realized that our design system has an open, wide eye diagram pattern which shows very least distortion in the signal strength to receiver.

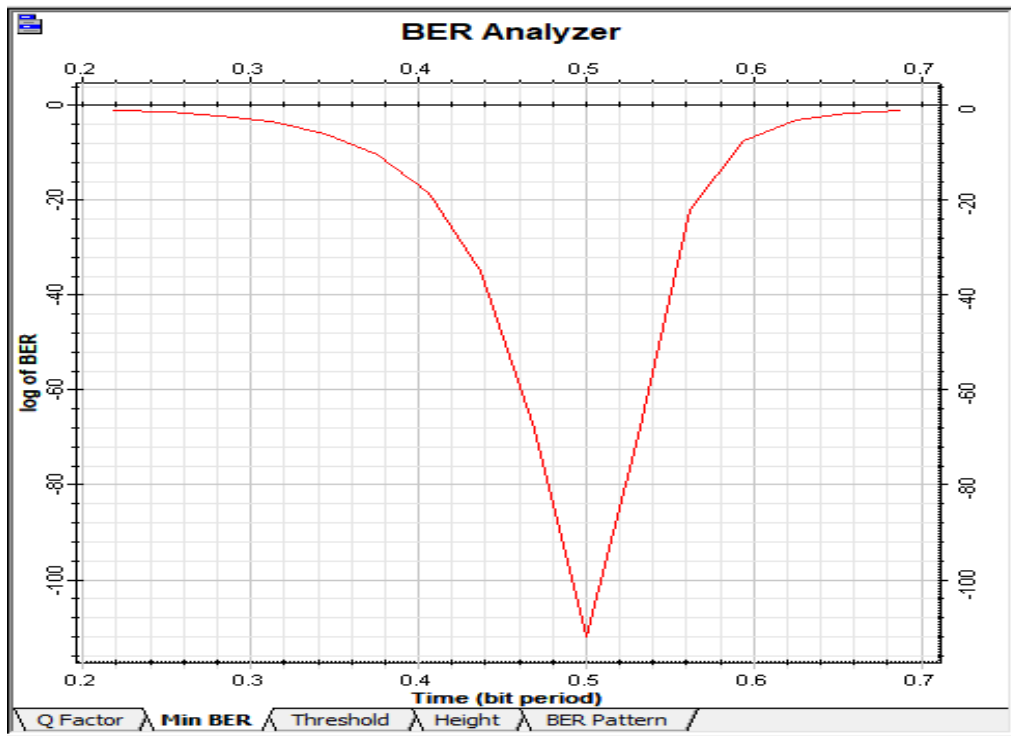

Figure 4.4 Minimum BER curve

Power transmitted and received by the system is described in Figure 05 where we have seen that efficient power has been received by receiver. The laser operating power is 15 dBm. The transmitted power has travelled through a long range distance 20,000 km is received -12.64 dBm at the receiver end.

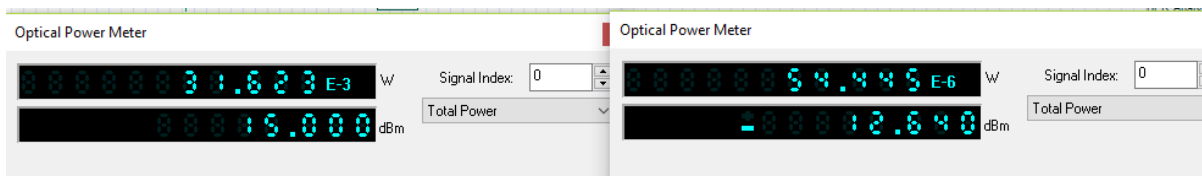

Figure 4.5: Transmitted and Received power by the system

### 4.3 Final Characteristics of the proposed system

Parameters	Value
Q factor	22.544
Min BER value	7.67863e -113
Data rate	20 Gbs
Distance covered	20,000 km
Power Received	-12.64 dBm
Frequency	193.1 THz

### 4.4 Comparison of the proposed system with existing work

Referenc e	[1]	[10]	[11]	[4]	[7]	Proposed
Distance (Km)	5,000	5,000	10,000	7,000	10,000	20,000
Data Rate (Gbs)	40	1	10	40	15	20
Q factor	6	99	37	11	10	23
Min BER	0.0007580 47	0.01	2.65 e- 123	5.625 e- 025	0.00095673	7.67863 e-113
Frequen cy (THz)	193.1	193.1	193.1	193.1	193.1	193.1
Tx Power (dBm)	30	30	10	30	15	15
Rx Power (dBm)	-10	-6	-7	-27	-11	-13

## **CHAPTER 05**

### **CONCLUSIONS**

#### **5.1 Conclusion**

More and more satellites are deployed to space to perform many applications for the benefit of mankind. The future of space technology aims for satellites that can send its research data and images from any parts of the world, and also satellites that can give high speed internet connection and provide mobile cellular services to people at any places and anytime. This project is done to analyze a method to connect and network these satellites by using optical link. It has been discussed that Is-OWC can provide intersatellite communication at higher speed and much further distance compared to RF links.

The project first objective which is to study OWC system for intersatellite links is accomplished successfully and discussed in Chapter 2. The design of IsOWC system was presented in Chapter 4 where the system model using OptiSystem software was explained in extensively. The project also aimed to simulate the system model for performance characterization and this has been conferred in Chapter 5. From the model simulation and the result findings, several conclusions can be drawn out.

#### **5.2 Future Scope and Recommendation**

Our proposed system was designed and simulated using Opti-System software version 16. From our evaluation result, it is found that they system provides a standard Q factor value and min BER value about 20 and 7.67863e-113 respectively which norms the system to give efficient signal strength for higher distance at 20,000 km which results in more higher and efficient data rate than various designed as mentioned in comparison TABLE 03. The proposed designed system is a simple and more efficient for higher distance than complex design did in order to increase distance in the designed system as shown in comparison table.

There more topics and area's that can be improved for this project. Due to that, the following topics are recommended for the IsOWC and intersatellite communication system improvements:

i. Path prediction model for intersatellite optical communication link

In this project, the OWC channel is assumed to be ideal where losses scattering and pointing errors are neglected. Therefore, a path prediction model for IsOWC system can be developed to have a better approximation of the real OWC channel.

ii. Development of intersatellite optical data network protocol

The network protocol can be beneficial for constellation of satellites that provides internet access or cellular mobile network. The encoding and channel multiple access methods can also be developed to improve the system performance.

iii. System Quality of Service (QoS) performance analysis by comparing to RF links

Several papers and books have mentioned the advantages of using optical link over RF link for intersatellite communication but none has really study in depth on the topic. QoS of the system is important to really prove that the optical link is much more favorable than RF link.

## REFERENCES:

- [1] P. Sharma and S. Meena, "Performance Analysis of Inter-Satellite Optical Wireless Communication (Is-OWC) System by Using Channel Diversity Technique," *2018 International Conference on Inventive Research in Computing Applications (ICIRCA)*, Coimbatore, 2018, pp. 477-480.
- [2] Gupta, Amit&Nagpal, Shaina. (2016). Design and Evaluation of 10-Gbps Inter-satellite Optical Wireless Communication Link for Improved Performance. *Journal of Optical Communications*. 38. 10.1515/joc-2016-0083.
- [3] J. B. Padhy and B. Patnaik, "DPSK and Manchester coding for Inter-satellite Optical Wireless Communication systems," *2018 IEEE 5th International Conference on Engineering Technologies and Applied Sciences (ICETAS)*, Bangkok, Thailand, 2018, pp. 1-5.
- [4] Khichar, Sunita& Kumar Inaniya, Pawan. (2018). Inter-Satellite Optical Wireless Communication System Design Using Diversity Technique with Filter and Amplifier. 0481-0484. 10.1109/ICCSP.2018.8524366.
- [5] Priya Sharma , SantoshMeena, Analysis of Pointing Error at 100 Gbps by using Different Encoding Technique in Spatial Diversity based Inter-Satellite Optical Wireless Communication (IS-OWC) System, *INTERNATIONAL JOURNAL OF ENGINEERING RESEARCH & TECHNOLOGY (IJERT)* Volume 07, Issue 09 (September – 2018).
- [6] A PanchalaBindushree, Nataraju A. B., Vijesh T V, Laxmiprasad A S, "Design and Simulation of QPSK Modulator for Optic Inter Satellite Communication".
- [7] SomanathPradhan, P.K. Sahu, Rajat Kumar Giri, BijayanandaPatnaik, "Intersatellite optical wireless system design using diversity techniques", *International Conference on Microwave, Optical and Communication Engineering*, December 18-20, 2015, IIT Bhubaneswar, India.

- [8] Pradhan, S &Panigrahy, R.K. &Mallick, Bandana &Patnaik, Bijayananda. (2017). Performance enhancement of an inter satellite optical wireless communication link by employing various modulation techniques. *International Journal of Mechanical Engineering and Technology*. 8. 224-232.
- [9] Singh, Rajbir. (2017). Analysis of Inter-Satellite Optical Wireless Communication System. *International Journals of Advanced Research in Computer Science and Software Engineering*. ISSN.2277-128. 10.23956/ijarcsse.v7i10.267.
- [10] I. K. Sri and A. Srinivasulu, "Q-factor and BER performance analysis of inter-satellite optical wireless communication using 26 transponders," *2017 International Conference on Intelligent Communication and Computational Techniques (ICCT)*, Jaipur, 2017, pp. 165-168.
- [11] Kaur, Prabhdeep, Amit Gupta and JaskaranKaur. "Simulative Analysis of DWDM Systems Using Loop Control in Inter Satellite Optical Wireless Communication Channel for 10,000 km Long Distance Transmission." (2016).
- [12] Pfennigbauer, M. and Leeb, W.R. Free-Space Optical Quantum Key Distribution Using Intersatellite Links. *CNES - Intersatellite Link Workshop*. November 2003.
- [13] Freeman, B. S. An Initial Analysis of Cost for Laser Communications and Optical Intersatellite Links, *SCEA Conference*, 2002.
- [14] Sibley, M.J.N. *Optical Communications*. London: Macmillan Education Ltd. 1990.
- [15] Tafazoli, R. *Technologies for the Wireless Future*, Vol. 2, England: John Wiley & Sons Ltd. 2006.
- [16] Jono, T., Takayama, Y., Shiratama, K., Mase, I., Demellenne, B., Sodnik, Z., Bird, A., Toyoshima, M., Kunimori, H., Giggenbach, D., Perlot, N., Knapek, M. and Arai, K. Overview of the inter-orbit and orbit-to-ground laser communication demonstration by OICETS, *Proceedings of SPIE, the International Society for Optical Engineering*, 2007.
- [17] Toyoshima, M., Takizawa, K., Kuri, T., Klaus, W., Toyoda, M., Kunimori, H., Jono, T., Takayama, Y., Mokuno, M. and Arai, K. Results of Groundto-Space Optical Communications Experiments using a Low Earth Orbit Satellite. *19th Annual Meeting of the IEEE* , 80-81, 2006.

- [18] Sbardellati, A., AleniaSpazioS.p.A., Sassorossi, T., Marinelli, M., and Giubilei, R. AIAA-1994-905, *15th AIAA International Communications Satellite Systems Conference*. Feb 28-Mar 3, 1994, Washington: American Institute of Aeronautics and Astronautics, 1994. 22-32.
- [19] Jamroz, W.R., Kruzelecky, R.V. and Haddad, E.I. *Applied Microphotonics*, USA: CRC Press. 2006.
- [20] Krainak, M.A. Intersatellite communications optoelectronics research at the Goddard Space Flight Center. *Telesystems Conference*, May 19-20, 1992. 14/9 -1412.
- [21] Held, K. J., and Barry, J. D.: 'Precision optical pointing and tracking from spacecraft with vibrational noise', Proc. SPIE 1986, 616, pp. 160-173. [2] Ruming, C.: 'MEO-LEO Satellite Communication', *Communications Science* 1997, 13 (7), pp. 44-48.
- [22] Chen, C. C. and Gardner, C. S.: 'Impact of random pointing and tracking errors on the design of coherent and incoherent optical intersatellite communication links', *IEEE transactions on Communications*, 1989, 37 (3), pp. 252-260.
- [23] S.Saini et.al, " Modeling and performance analysis of DWDM based 100 Gbps Low power Inter-satellite Optical wireless Communication(Lp-IsOWC) system" SOP TRANSACTIONS ON SIGNAL PROCESSING, Volume 2, Number 1, January 2015.
- [24] K. Wilson, and M. Enoch, "Optical Communications for Deep Space Mission," *IEEE Commun. Magazine* 38, 134-139 (2000).
- [25] <http://telecom.esa.int/telecom/www/object/index.cfm?fobjectid=8929>
- [26] J. Prat, A. Napoli, J.M. Gené, M. Omella, P. Poggiolini, and V. Curri, "Square root strategy: A novel method to linearise an optical communications system with linear equalizers". in Proc. ECOC 2005, Glasgow U.K., 2005, Paper We4.P.106.