

DESIGN AND IMPLEMENTATION OF A SOLAR-BASED RAILWAY TRACK CRACK DETECTION SYSTEM USING ULTRASONIC SENSOR

by

MOHAMMAD ABDUL AHAD SHOYON

RAFI HASAN

**BACHELOR OF SCIENCE IN ELECTRICAL AND ELECTRONIC
ENGINEERING**



Department of Electrical and Electronic Engineering
INTERNATIONAL ISLAMIC UNIVERSITY CHITTAGONG

MAY 2018

**DESIGN AND IMPLEMENTATION OF SOLAR
BASED RAILWAY TRACK CRACK DETECTION
SYSTEM USING ULTRASONIC SENSOR**

by

MOHAMMAD ABDUL AHAD SHOYON

RAFI HASAN

A project

Submitted as partial fulfilment of the requirement for the degree of

**BACHELOR OF SCIENCE IN ELECTRICAL AND ELECTRONIC
ENGINEERING**

Department of Electrical and Electronic Engineering
INTERNATIONAL ISLAMIC UNIVERSITY CHITTAGONG

MAY 2018

CERTIFICATE OF APPROVAL

The thesis/project entitled as “**Design and Implementation of Solar Based Railway Track Crack Detection System Using Ultrasonic Sensor**” submitted by **Rafi Hasan**, bearing Matric ID. **ET-133038** and **Mohammad Abdul Ahad Shovon**, bearing Matric ID. **ET-133027** of session **Autumn 2013**, to the Department of Electrical and Electronic Engineering, International Islamic University Chittagong, has been accepted as satisfactory in partial fulfilment of the requirements for the degree of Bachelor of Science in Engineering and approved for the examination held on **18th May, 2018**.

Supervisor
Engr. Md. Rashidul Islam
Assistant Professor,
Department of Electrical and Electronic Engineering
International Islamic University Chittagong.

DECLARATION

It is hereby declared that this work has been done by us and no portion of the work contained in this project has been submitted elsewhere for the award of any degree or diploma.

Mohammad Abdul Ahad Shovon

Rafi Hasan

ACKNOWLEDGMENT

All praises and thanks to Allah, the Lord of the world, the most Beneficent, the most Merciful for helping us to accomplish this work.

We are beholden to a number of people, who supported us to carry out this work. For this prototype development and report preparation, we would like to thank our project supervisor Engr. Md. Rashidul Islam, Assistant Professor, Department of Electrical and Electronic Engineering for his inspiration, enormous support and careful guidance. Without his guidance, it was almost impossible to continue with the project work. He was very helpful and ever affectionate to endure the mistakes we had committed to the project and always encouraged us by correcting our wrong proceedings. It was only the endless support offered by him that enabled us to complete this devoted task.

We want to extend my gratitude to all the teachers of our department for their affection and support. I am also very thankful to all my classmates and friends who always encouraged me and provided me with suggestions at various steps in completion of this work.

Finally, we would also like to thank our parents and all my family members and my well-wishers who gave inspirations all the time for completing the project.

Authors

ABSTRACT

In Bangladesh, railway communication is very important due to its low cost involvement. But there is an accident issue as well which is a real concern for this sector. In the current railway system, it is more necessary to have safety elements in order to avoid accidents. One of the important causes that can provoke serious accidents is the existence of crack on the track. At present, the cracks in the railway tracks are checked by manual system. Therefore, this project work deals with one of the efficient methods to avoid train accidents and crack detection. The design of the system consists of a Global Positioning System (GPS) module, Global System for Mobile (GSM) module and Ultrasonic sensor. In this project work, ultrasonic sensor is used to detect the crack in the railway tracks by measuring the distance from the track to the sensor. If the distance is greater than the assigned value, then the microcontroller identifies that there is a crack. The longitude and latitude of the track location are messaged to the nearest railway station using GPS and GSM modules. It is an effective and cost-efficient system for railway applications.

TABLE OF CONTENTS

CERTIFICATE APPROVAL	ii
DECLARATION	iii
ACKNOWLEDGEMENT	iv
ABSTRACT	v
TABLE OF CONTENTS	vi
LIST OF FIGURES	ix
LIST OF TABLES	x
LIST OF ABBREVIATIONS	xi
CHAPTER 1 INTRODUCTION	1
1.1 Background	1
1.2 Problem Statement	1
1.3 Objectives	2
1.5 Outline of the Report	2
CHAPTER 2 LITERATURE REVIEW	3
2.1 Introduction	3
2.2 Summary of Previous Work	3
2.2.1 Machine Vision Based Missing Fastener Detection In Rail Track Images Using Sum Classifier	3
2.2.2 Robust Railway Crack Detection Scheme (Rrcds) Using Led-LDR Assembly	5
2.2.3 Crack Detection System for Railway Track By Using Ultrasonic and PIR Sensor	9
CHAPTER 3 METHODOLOGY	11
3.1 Introduction	11
3.2 MCU - PIC18F452	11
3.2.1 Specifications of Microcontroller	12
3.2.1.1 High-Performance RISC CPU	12
3.2.1.2 Peripheral Features	13

3.2.1.3	Special Microcontroller Features	13
3.2.1.4	CMOS Technology	14
3.2.1.5	I/O and Packages	14
3.2.2	Pin Description	14
3.3	SIM800L GSM Module	17
3.3.1	Features of GSM Module	17
3.4	DC Gear Motor	18
3.4.1	Specifications of DC Gear Motor	19
3.5	Ultrasonic Sensor HCSR04	20
3.5.1	Features of Ultrasonic Sensor	20
3.5.2	Operation	21
3.6	Buck Converter	22
3.6.1	Operation	22
3.7	LCD Display 16x2	23
3.7.1	Command Register	23
3.7.2	Data Register	23
3.7.3	Rw(Read - Write)	23
3.7.4	En (Enable signal)	23
3.7.5	V ₀ (Set LCD contrast)	24
3.7.6	Pin Diagram	24
3.7.7	Pin Description	25
3.8	SPDT Switch	26
3.9	BC547 Transistor	26
3.9.1	Pin Configuration	27
3.9.2	Feature	28
3.10	Solar Panel (2W)	28
3.10.1	Specifications	29
3.11	Resistor	29
3.12	Diode IN4007	30
3.12.1	Specifications	31
3.13	Crystal Oscillator	31
3.13.1	Specification	32
3.14	Capacitor	32
3.15	Block Diagram	33
3.16	Circuit Diagram	34

CHAPTER 4 RESULTS AND DISCUSSION	36
4.1 Introduction	36
4.2 Outlook of the designed prototype	36
4.2.1 Side view of the project	36
4.2.2 Top view of the project	37
4.3 Results steps analysis	37
4.4 Cost analysis	42
4.5 Advantage	44
4.6 Limitation	44
4.7 Application	44
4.8 Discussion	44
CHAPTER 5 CONCLUSION AND FUTURE WORK	45
5.1 Conclusion	45
5.2 Future Improvement	45
REFERENCES	46
APPENDIX	48

LIST OF FIGURES

Fig. 2.1	Proposed fastener classification system	4
Fig. 2.2	Functional Block Diagram	5
Fig. 2.3	S3C2440AMicrocontroller	6
Fig. 2.4	Robust Railway Crack Detection Scheme	8
Fig. 2.5	Block Diagram	10
Fig. 3.1	PIC18F452 Microcontroller	12
Fig. 3.2	PIC18F452 with Pin Identification	14
Fig. 3.3	SIM800L GSM Module	17
Fig. 3.4	DC Gear Motor	19
Fig. 3.5	Ultrasonic Sensor HCSR04	20
Fig. 3.6	Operation of HC-SR04 Ultrasonic Sensor	21
Fig. 3.7	Calculation of Distance Measurement	22
Fig. 3.8	Buck Converter	22
Fig. 3.9	16x2 LCD Display	24
Fig. 3.10	Pin Diagram of 16x2 LCD Display	24
Fig. 3.11	SPDT Switch Circuit Symbol and ASPDT Slide Switch	26
Fig. 3.12	BC547 Transistor Pin out	27
Fig. 3.13	Solar Panel	29
Fig. 3.14	IN4007 Diode	30
Fig. 3.15	8MHz Crystal Oscillator	31
Fig. 3.16	100nF Capacitor	33
Fig. 3.17	1000 μ F Capacitor	33
Fig. 3.18	Block diagram of solar based crack detection system using	33
Fig. 3.19	Circuit diagram of the designed project	34
Fig. 3.20	Flow chat of the designed project	35
Fig. 4.1	Side View of the project	36
Fig. 4.2	Top view of the project	37
Fig. 4.3	Train ready for start and searching the location	38
Fig. 4.4	Detected Current location has been shown in the display	38
Fig. 4.5	Train is moving on the track	38
Fig. 4.6	Faulty section of the track	39
Fig. 4.7	Detecting fault and then searching for longitude and latitude	39
Fig. 4.8	Now sending the SMS to the predefined no. (Concern Authority)	40
Fig. 4.9	SMS has been sent	40
Fig. 4.10	Received SMS by the Concern Authority	41
Fig. 4.11	Based on the longitude and latitude location name in Google MAP	42

LIST OF TABLES

Table 3.1	Pin Description of PIC18F452 Microcontroller	15
Table 3.2	Pin Description of 16x2 LCD Display	25
Table 3.3	Pin Configuration of BC547 Transistor	27
Table 4.1	Cost of the equipment's used in this project	43

LIST OF ABBREVIATIONS

GSM Global System for Mobile communication

PV Photovoltaic

SMS Short Message Service

GPS Global Positioning System

LCD Liquid Crystal Display

LED Light Emitting Diode

MCU Micro Controller Unit

PCP Parallel Slave Port

PWRT Power up Timer

OST Oscillator Start up Timer

CCTV Closed Circuit Television

ICD IN-Circuit Debug

DWT Discrete Wavelet Transform

CHAPTER 1

INTRODUCTION

1.1 Background

Nowadays, Railway system requires proper and regular maintenance of the rail track for safety of the passengers who are travelling by train. This present system requires lot of man power to inspect the rail track for detecting any crack in track. It is also required to get some trained experts in this field. It is time consuming and costly process and it is not suitable for long rail tracks. This manual verification of rail track sometimes leads to accident and it is very dangerous for humans who are inspecting the rail tracks in rainy seasons. At present, many researchers is developing an automatic rail track inspection system where man power is not required. This is very safe process and cost effective process. This automatic detection system consists of automatic rail track defects detection, automatic fastener defects detection and rail track gauge determination. Fasteners are the connectors which connects two subsequent rail tracks in linear manner. Intact, Partially worn and missing fasteners are types of fasteners. Most of the rails accidents are occurring due to the missing fasteners in rain track. Most of the train accidents and train derailment are occurred due to these missing fasteners in rail track. Hence, this paper proposes an automatic computer aided approach for the detection of fasteners in rail track. In this project work, computer vision algorithms are developed to detect the missing fasteners in rail track in an automated manner.

1.2 Problem Statement

As days goes the railway accident becoming a very common phenomenon in our country and because of that large number of death occurs. Again, most of the railway accident occurs due to the line fault that means the line fault sometimes not properly detected by the concerning authority. So, based on the above concern we need to find out a railway line fault detection system which can prevent the rail accident.

1.3 Objectives

In this research work automatic railway line fault detection system has been proposed and a prototype has also been designed. The main objective of the proposed project has been given below:

- i. Developing automatic railway line fault detection system to prevent the rail accident
- ii. Ensuring safe and sound journey
- iii. Designing and implementing reliable and low cost solar based railway track crack system Using Ultrasonic Technology

1.4 Thesis Outline

In this, we described and discussed about our project in five chapters. The outline of our thesis are as follows:

Chapter 1 is an overview of the research project in whole, the problem statement, objective are defined. The research project that will be done are based on the objectives and scopes that been stated earlier.

Chapter 2 presents the literature review of the railway track crack project. Studies in literature review helps in understanding the fundamental of the project.

Chapter 3 will discuss about the methodology that shall adopt for this project work which basically defined the planning process flow and major parts of the hardware and software implementation. The hardware development and circuit design will be discussed in detail in this chapter.

Chapter 4 contains the project testing and the result. Where the collected data from experimental work will be gathered before the analysis will be performed.

Chapter 5 will conclude all the works and had been presented in the previous chapter and all the results of the project. This is followed by recommendations for the future study work.

CHAPTER 2

LITERATURE REVIEW

2.1 Introduction

Rubel Biswas et al [1]. in (2016) proposed Harris –Stephen feature detection based SVM classification approach for the detection of missing fasteners in rail track images. The authors achieved 81.25% of classification accuracy for their proposed missing fastener detection algorithm. In 2015, Jiajia Liu et al [2]. Used SVM classification method to classify the test rail track image into either track with fastener or track without fasteners. The authors achieved recall rate of 87.3% for detecting the missing fasteners in rail track images. Xia et al [2]. (2010) applied a methodology for the detection of hook-shaped fastener in rail track images. The authors used linear boost algorithm for the detection process and achieved 93.7% of classification accuracy for their proposed classification methods. This method was suitable for both low and high resolution rail track images. M. Singhet al [3]. (2006) applied various edge detection methods on rail track images in order to detect the missing fasteners in rail track images. The authors achieved 78% of precision and 76% of recall rate of their proposed missing fastener detection system. L. Mazzeo et al. (2004) developed a fastener detection methodology which efficiently detected missing fasteners in rail track images. The authors used ada boost classifier to classify the preprocessed rail track image into either track with fastener or track without fastener.

2.2 Summary of Previous Work

Some of the previous works related to this project are summarized below.

2.2.1 Machine vision based missing fastener detection in rail track images using SVM classifier

The modules which are used in proposed fastener detection process is illustrated in Fig 2.1. This proposed system consists of preprocessing, transformation, feature extraction and classifications.

Image resizing is performed as preprocessing step and Gabor transform is used as transformation technique. GLCM features, LBP features and DWT are used as features in this paper. SVM classifier is used as classifier in order to classify the test rail track image into either track image with fastener or track image without fastener.

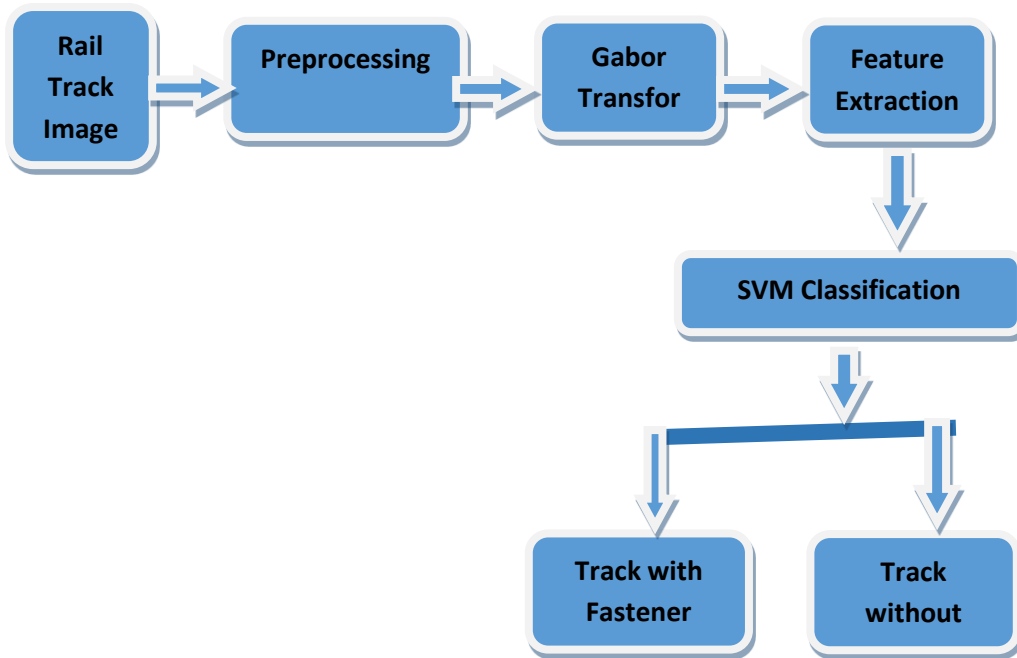

Fig. 2.1 Proposed fastener classification system [1]

➤ Preprocessing

The rail track images are RGB image in its nature. Preprocessing is used to convert the RGB image into grey scale image due to its speed processing. Then, this grey scale image is resized into 128 width *128 height image as fixed image size.

➤ Gabor transform

The multi resolution transform is used to convert the spatial domain image into multi resolution image which is in the form of amplitude, frequency and phase. Conventional multi resolution transforms such as Discrete Wavelet Transform (DWT), Contour let and Curve let converted the spatial domain image into multi resolution image with low accuracy. In order to overcome such limitations of the conventional classifiers, Gabor transform is used in this paper to obtain the multi resolution image from the spatial domain rail track image.

➤ Feature Extraction

Features are the key elements in differentiating the track image without fastener from track image with fastener. In this paper, GLCM, LBP and DWT features are extracted from the Gabor transformed rail track image.

2.2.2 Robust Railway Crack Detection Scheme (RRCDS) using LED-LDR assembly

An Embedded system is a combination of software and hardware to perform a dedicated task. Some of the main devices used in embedded products are Microprocessors and Microcontrollers. Microprocessors are commonly referred to as general purpose processors as they simply accept the inputs, process it and give the output. In contrast, a microcontroller not only accepts the data as inputs but also manipulates it, interfaces the data with various devices, controls the data and thus finally gives the result. The —Robust Railway Crack Detection Scheme (RRCDS) Using LED-LDR Assembly using ARM9 microcontroller is an exclusive project which is used to detect the cracks in railway track.

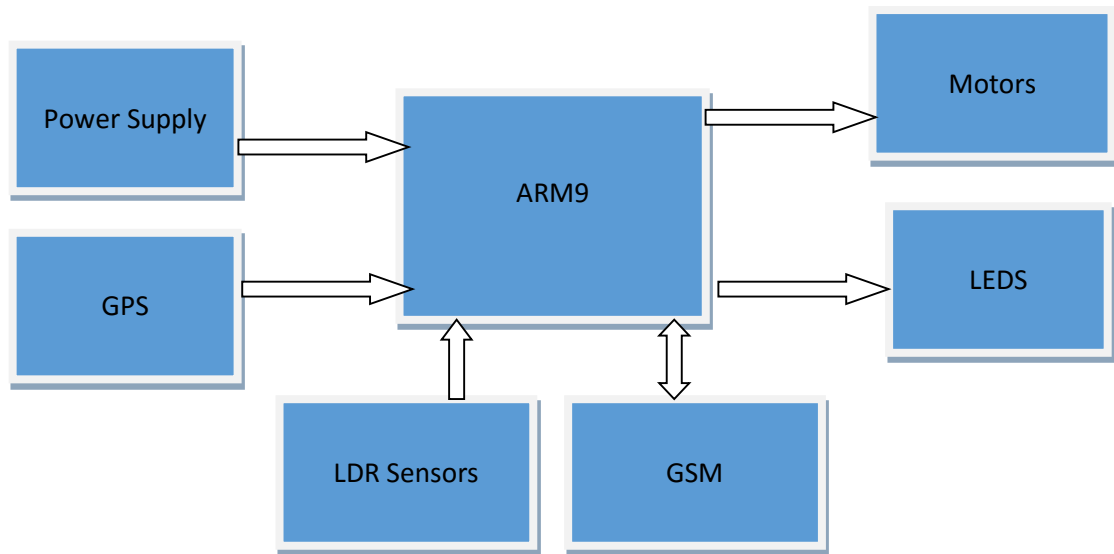

Fig 2.2 Functional block diagram of Robust Railway Crack Detection Scheme (RRCDS) using LED-LDR assembly [4]

➤ S3C2440AMicrocontroller

Samsung'sS3C2440A 16/32-bit RISC microprocessor. Samsung'sS3C2440A is designed to provide hand-held devices and general applications with low-power, and high-performance microcontroller solution in small die size. To reduce total system cost, the S3C2440A

includes the following components. The S3C2440A is developed with ARM920T core, 0.13 um CMOS standard cells and a memory complier. Its low power, simple, elegant and fully static design is particularly suitable for cost-and power-sensitive applications. It adopts a new bus architecture known as Advanced Micro Controller Bus Architecture (AMBA). The S3C2440A offers outstanding features with its CPU core, a 16/32-bit ARM920T RISC processor designed by Advanced RISC Machines, Ltd. The ARM920T implements MMU, AMBA BUS, and Harvard cache architecture with separate 16 KB instruction and 16 KB data caches, each with an 8-word line length. By providing a complete set of common system peripherals, the S3C2440A minimizes overall system costs and eliminates the need to configure additional components



Fig 2.3: S3C2440AMicrocontroller [4]

➤ LCD

LCD stands for liquid crystal display. It is an output device and mainly used for displaying the characters, numbers and any type of special characters. Previously in place of LCD they have used seven-segment Display. Here the cost of LCD is low as compared to the seven-segment display. Now a day's LCD plays a major role. In this project LCD is used for displaying the value of temperature and humidity. For example, if the temperature value is

30 degrees centigrade then it displays as 30 degrees. It also displays the status of lights in home whether they are ON or OFF.

➤ GSM

A GSM modem is a wireless modem that works with a GSM wireless network. A wireless modem behaves like a dial-up modem. The main difference between them is that a dial-up modem sends and receives data through a fixed telephone line while a wireless modem sends and receives data through radio waves. A GSM modem can be an external device or a PC Card PCMCIA Card. Typically, an external GSM modem is connected to a computer through a serial cable or a USB cable. A GSM modem in the form of a PC Card / PCMCIA Card is designed for use with a laptop computer. It should be inserted into one of the PC Card / PCMCIA Card slots of a laptop computer. Like a GSM mobile phone, a GSM modem requires a SIM card from a wireless carrier in order to operate.

➤ GPS

The Global Positioning System (GPS) is a satellite-based navigation system that sends and receives radio signals. A GPS receiver acquires these signals and provides us with information. Using GPS technology, we can determine location, velocity, and time, 24 hours a day, in any weather conditions anywhere in the world—for free. GPS, formally known as the NAVSTAR (Navigation Satellite Timing and Ranging). Global Positioning System originally was developed for the military. Because of its popular navigation capabilities and because we can access GPS technology using small, inexpensive equipment, the government made the system available for civilian use. The USA owns GPS technology and the Department of Defense maintains it. The signals can pass through clouds, glass, and plastic. Most solid objects such as buildings attenuate (decrease the power of) the signals. The signals cannot pass through objects that contain a lot of metal or objects that contain water (such as underwater locations). The GPS satellites are powered by solar energy. If solar energy is unavailable, for example, when the satellite is in the earth's shadow, satellites use backup batteries to continue running.



Fig 2.4 Robust railway crack detection scheme [4]

The mechanical design of the project is clearly illustrated. The LED-LDR's can be fixed on the track or they can be attached to the robot or in advance they can be set to the engine itself. The signals i.e, the light from the LED continuously falls on the LDR when they are set to the means like the robot or the engine, as when the crack is detected the light outsourcing from the LED doesn't fall on the LDR by which the resistance is calculated at this point of time and then the current positions are captured using the GPS and the latitude and the longitude positions are sent to the mobile using the GSM module. On board the implementation is shown when the obstacle is placed in between the LED and LDR the motor which is rotating continuously specifying that the there is no crack will get to rest position, at this point of time the current latitude and longitudinal positions are captured by the GPS and the locations are sent to the mobile via SMS through GSM. There are few more design criteria which were taken into account:

- The wheels of the robot will be similar to the wheels of the train, i.e. a big wheel welded/joined with a smaller wheel. The smaller wheel runs on the track while the bigger one prevents the robot from falling. It is must that the bigger wheel is on the inner side of the railway track. It is because in the general Indian scenario the stones and other debris are comparatively less on the inner side tracks. If the bigger wheels are placed outside it may brush against the debris causing it to destabilize or in worst case get stuck or even fall.

- The LED-LDR assembly shouldn't go below the rim of the rail otherwise it may get damaged due to the scattered debris.

2.2.3 Crack detection system for railway track by using ultrasonic and PIR Sensor

Ultrasonic inspection of rails is usually restricted to low speeds of around 20-30 mph, which limits the viability of testing many tracks regularly. Furthermore, many of the most serious defects that can develop in the rail head can be very difficult to detect using the currently available inspection equipment. One of the reasons for slow inspection speeds using conventional NDT is the need for coupling between the transducer and the track using either liquid or dry coupling materials. EMATs have been used 2,3 or suggested 4 to measure both rail tracks and wheels by other workers and the use of non-contact ultrasonic measurements are still being investigated by a number of international research groups. In this method we discuss the use of EMATs on rail for longitudinal and transverse crack defect detection and depth gauging. Ultrasonic surface waves that are similar in behavior to Rayleigh waves are an obvious candidate for surface breaking crack detection. If a defect lies between the Rayleigh wave generator and detector, then it will to some degree block the Rayleigh wave. The amplitude of a Rayleigh wave displacement decays with depth into the sample and most of the energy associated with a particular frequency lies within a depth equal to one wavelength at that frequency. Almost all of the energy lies within a depth corresponding to two wavelengths. The different frequency components will effectively probe to different depths below the sample surface. In a measurement where we attempt to propagate a Rayleigh wave through a region containing a surface breaking crack, the crack depth can be estimated by the amount of Rayleigh wave energy or amplitude that is transmitted through or underneath that region. Closed or partially closed cracks can obviously complicate the analysis and increase the amount of Rayleigh wave energy transmitted through the crack compared to an open crack

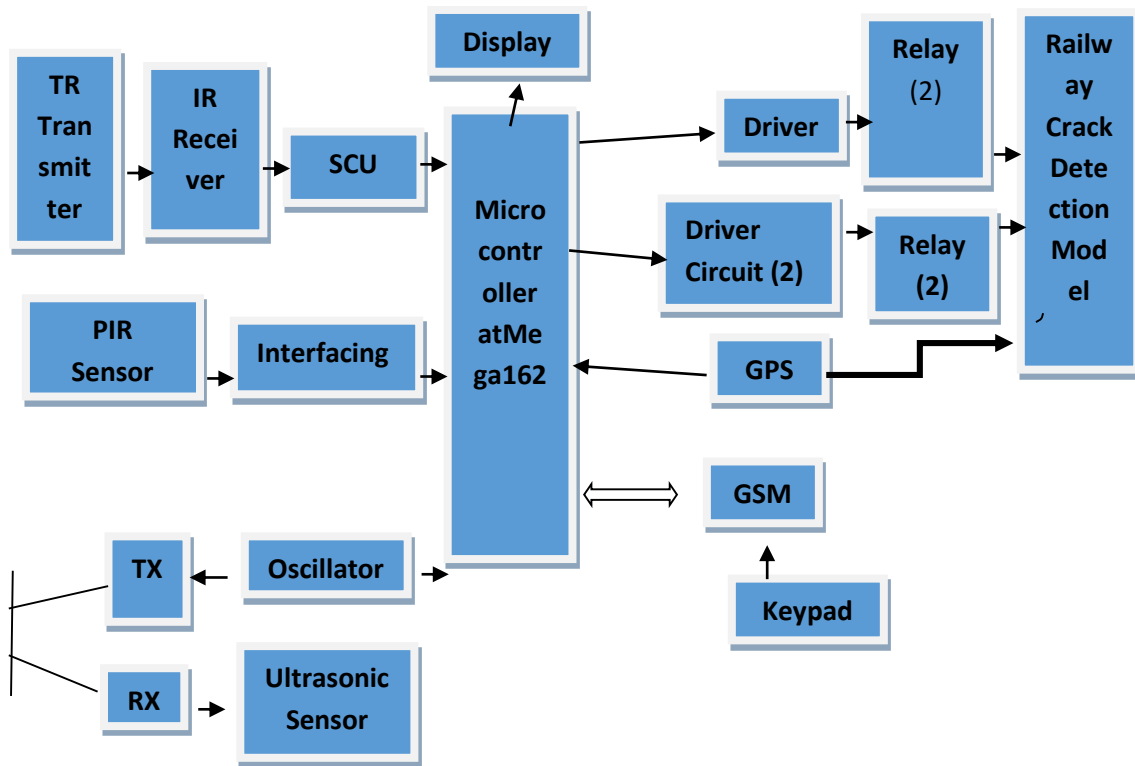

Fig 2.5 Block diagram crack detection system for railway track by using ultrasonic and PIR Sensor [5]

Passive Infra-Red sensors (PIR sensors) are electronic devices which measure infrared light radiating from objects in the field of view. PIRs are often used in the construction of PIR-based motion detectors, see below. Apparent motion is detected when an infrared emitting source with one temperature, such as a human body, passes in front of a source with another temperature, such as a wall. To traverse a distance of 22 Km in 4 hrs. An average speed of 1.5 meters/sec is needed. The proposed design uses 4 DC motors. DC motor works according to relay operation.

- When relay 1 is in the ON state and relay 2 is in the OFF state, the motor is running in the forward direction.
- When relay 2 is in the ON state and relay 1 is in the OFF state, the motor is running in the reverse

CHAPTER 3

METHODOLOGY

3.1 Introduction

In this chapter, the major parts of the hardware and circuit design is discussed in detail. Concept and operation circuit combination power supply, current input circuit and control circuit will be discussed with more advanced. The development of this project is based on several types of devices. These devices are listed below.

Component list:

- MCU - PIC18F452
- SIM800L GSM Module
- Relay
- Buzzer
- Ultrasonic Sensor
- 2 line 16X2 LCD display
- Transistor
- 9 V DC Gear Motor
- Solar Panel
- Variable Resistor
- 100 nF , 1000 μ F Capacitor
- 10 k, 3.3 k, 1 k, 47 k, 1.8 k Resistor

3.2 MCU - PIC18F452

The PIC18F452 microcontroller from Microchip Technology has 16 K of code space, 10-bit A/D converters, 34 I/O pins and many other features in a 40-pin DIP package [6]. A PIC18F452 Microcontroller is shown in **Fig. 3.1**.



Fig. 3.1 PIC18F452 Microcontroller [6]

3.2.1 Specifications of Microcontroller

- Full Speed USB 2.0 (12Mbit/s) interface
- DC Operating Frequency (40 MHz)
- 32 Kbytes Programme Memory (Flash)
- 1K byte Dual Port RAM + 1K byte GP RAM
- Full Speed Transceiver
- 16 Endpoints (IN/OUT)
- Streaming Port
- Internal Pull Up resistors (D+/D-)
- 40 MHz performance (12 MIPS)
- Pin-to-pin compatible with PIC16C7X5

3.2.1.1 High-Performance RISC CPU

- Source code compatible with the PIC16 and PIC17 instruction sets
- Linear program memory addressing to 32 Kbytes
- DC - 40 MHz osc/clock input
- 16-bit wide instructions, 8-bit wide data path
- Priority levels for interrupts
- 8 x 8 Single Cycle Hardware Multiplier

- 16 Kbytes Flash Program Memory
- 1536 Byte RAM Data Memory
- 256 Byte RAM Data Memory

3.2.1.2 Peripheral Features

- High current sink/source 25 mA/25 mA
- Two 16-bit timer/counter (TMR1, TMR3)
- One 8-bit/16-bit timer/counter with presales
- One 8-bit timer/counter with 8-bit period register
- Capture 16-bit, max. resolution 6.25ns(TCY/16)
- Compare 16-bit, max. resolution 100ns
- 3-wire SPI (supports all 4 SPI modes)
- I²C Master and Slave mode
- Addressable USART Module supports RS-485 and RS-232
- Parallel Slave Port (PSP) module
- Eight Channel 10-bit Analog-to-Digital Converter

3.2.1.3 Special Microcontroller Features

- Power-On Reset
- Power-up Timer (PWRT) and Oscillator Start-Up Timer (OST)
- 1,000 erase/write cycles Enhanced Flash Program Memory
- 1,000,000 typical erase/write cycles EEPROM Data Memory
- Watchdog Timer (WDT) with its own On-Chip RC oscillator
- Programmable code protection
- Power saving SLEEP mode
- 4X Phase Lock Loop (of primary oscillator)
- Secondary Oscillator (32 kHz) clock input
- Single supply 5 V In-circuit Serial Programming via two pins
- In-Circuit Debug (ICD)

3.2.1.4 CMOS Technology

- Low power, high speed CMOS FLASH technology
- Fully Static Design
- Wide Operating Voltage Range (2.0 V to 5.5 V)

3.2.1.5 I/O and Packages

- 34 I/O pins with individual direction control
- 40-pin DIP

3.2.2 Pin Description

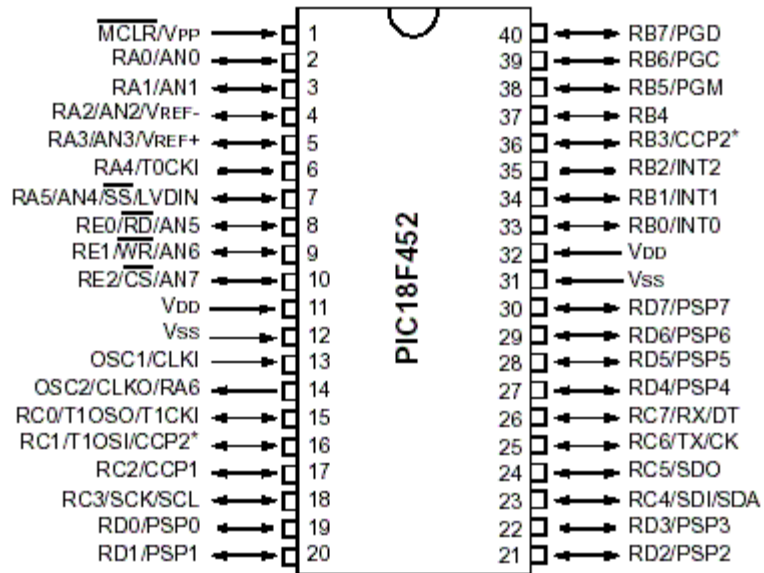

Fig. 3.2 PIC18F452 with pin identification [6]

Fig. 3.2 Pin identification of PIC18F452 Microcontroller. The pins are described below in a table.

Table 3.1 Pin description of PIC18F452 microcontroller

Pin Number	Description
1	MCLR/VPP - Master Clear Reset
2	RA0/AN0 - Port A
3	RA1/AN1 - Port A
4	RA2/AN2/VREF- - Port A
5	RA3/AN3/VREF+ - Port A
6	RA4/T0CKI - Port A
7	RA5/AN4/SS/LVDIN - Port A
8	RE0/RD/AN5 - Port E
9	RE1/WR/AN6 - Port E
10	RE2/CS/AN7 - Port E
11	Vdd - Positive Power Supply
12	Vss – Ground
13	OSC1/CLKI – Oscillator
14	OSC2/CLKO/RA6 - Port A
15	RC0/T1OSO/T1CKI - Port C
16	RC1/T1OSI/CCP2 - Port C

17	RC2/CCP1 - Port C
18	RC3/SCK/SCL - Port C
19	RD0/PSP0 - Port D
20	RD1/PSP1 - Port D
21	RD2/PSP2 - Port D
22	RD3/PSP3 - Port D
23	RC4/SDI/SDA - Port C
24	RC5/SDO - Port C
25	RC6/TX/CK - Port C
26	RC7/RX/DT - Port C
27	RD4/PSP4 - Port D
28	RD5/PSP5 - Port D
29	RD6/PSP6 - Port D
30	RD7/PSP7 - Port D
31	Vss – Ground
32	Vdd - Positive Power Supply
33	RB0/INT0 - Port B
34	RB1/INT1 - Port B
35	RB2/INT2 - Port B
36	RB3/CCP2 - Port B

37	RB4 - Port B
38	RB5/PGM - Port B
39	RB6/PGC - Port B
40	RB7/PGD - Port B

3.3 SIM800L GSM Module

The SIM800L GSM module supports quad-band GSM/GPRS network, available for GPRS and SMS message data remote transmission. The SIM800L communicates with microcontroller via UART port, supports command including 3GPP TS 27.007, 27.005 and SIMCOM enhanced AT Commands. It also has built-in level translation, so it can work with microcontroller of higher voltage than 2.8 V default [7]. Besides, the board also supports A-GPS technique which is called mobile positioning and gets position by mobile network. A SIM800L GSM modules shown in **Fig. 3.3**.

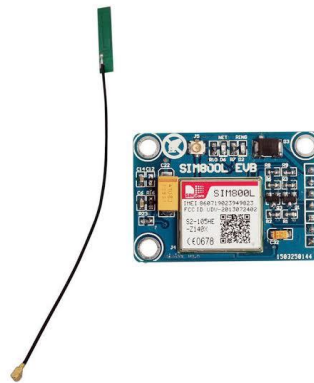

Fig. 3.3 SIM800L GSM module [7]

3.3.1 Features of GSM Module

Features of SIM800L GSM Module [7]. is given below...

- Quad-band 850/900/1800/1900MHz
- GPRS multi-slot class12 connectivity: max. 85.6 kbps(down-load/up-load)
- GPRS mobile station class B
- Controlled by AT Command (3GPP TS 27.007, 27.005 and SIMCOM enhanced AT Commands)
- Supports Real Time Clock
- Supply voltage range 3.4 V ~ 4.4 V
- Supports A-GPS
- Supports 3.0 V to 5.0 V logic level
- Low power consumption, 1 mA in sleep mode
- Compact size 23 mm x 35 mm x 5.6 mm
- Micro SIM Card

3.4 DC Gear Motor

DC motors are motion components that take electrical power in the form of direct current (or some manipulated form of direct current) and convert it into mechanical rotation. The motors do this through the use of magnetic fields that arise from the electric currents to spur rotation of a rotor fixed with an output shaft. Output torque and speed depends on the electrical input and motor design. In this project operation we used a geared DC motor. A geared DC Motor has a gear assembly attached to the motor. The speed of motor is counted in terms of rotations of the shaft per minute and is termed as RPM. The gear assembly helps in increasing the torque and reducing the speed. Using the correct combination of gears in a gear motor, its speed can be reduced to any desirable figure. This concept where gears reduce the speed of the vehicle but increase its torque is known as gear reduction. This Insight will explore all the minor and major details that make the gear head and hence the working of geared DC motor. A DC gear motor is shown in **Fig. 3.4**



Fig. 3.4 DC gear motor

3.4.1 Specifications of DC Gear Motor

- Output speed: $150 \pm 10\%$ rpm
- No load Current: 200 mA (Max)
- Stall current: 4500 mA(max)
- Stall torque: 9.5 kg NaN
- Rated speed: $100 \pm 10\%$ rpm
- Rated torque: 3000 g NaN
- Rated Current: 1200 mA (Max)
- Noise: 56 dB
- Working voltage: 9 V
- Diameter: 25 mm
- Outside Shaft Length: 14.5 mm
- Shaft End Play: 0.05-0.50 mm
- Screw Size: M3.0
- Encoder: 2 pulses/circle

3.5 Ultrasonic Sensor HCSR04

The HC-SR04 ultrasonic sensor uses sonar to determine distance to an object like bats do. It offers excellent non-contact range detection with high accuracy and stable readings in an easy-to-use package. From 2 cm to 400 cm or 1" to 13 feet. Its operation is not affected by sunlight or black material like Sharp rangefinders are (although acoustically soft materials like cloth can be difficult to detect). It comes complete with ultrasonic transmitter and receiver module. The HC-SR04 Ultrasonic Module has 4 pins, Ground, VCC, Trig and Echo. An Ultrasonic Sensor HCSR04 is shown in **Fig. 3.5**.



Fig. 3.5 Ultrasonic sensor HCSR04

3.5.1 Features of Ultrasonic Sensor

Features of HC-SR04 Ultrasonic Sensor is given below...

- Power Supply: +5V DC
- Quiescent Current: <2 mA
- Working Current: 15 mA
- Effectual Angle: <15°
- Ranging Distance: 2 cm – 400 cm / 1" – 13 ft
- Resolution: 0.3 cm
- Measuring Angle: 30 degree
- Trigger Input Pulse width: 10 μ S
- Dimension: 45 mm x 20 mm x 15 mm

➤ 3.5.2 Operation

It emits an ultrasound at 40 000 Hz which travels through the air and if there is an object or obstacle on its path It will bounce back to the module as shown in the **Fig. 3.6** Considering the travel time and the speed of the sound we can calculate the distance.

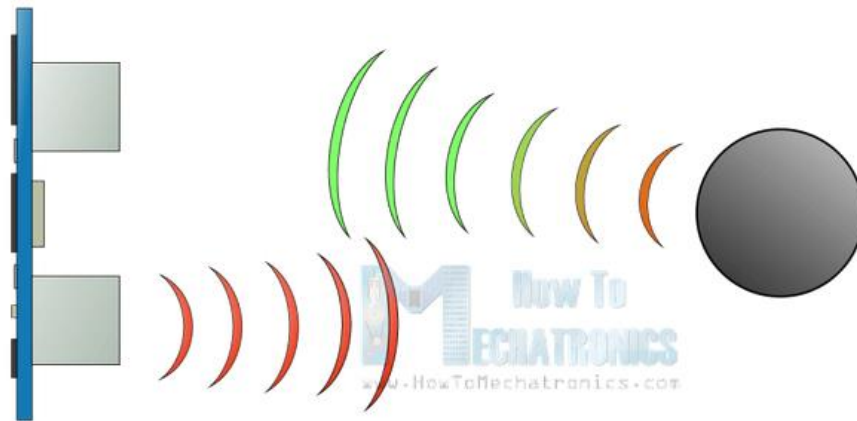

Fig. 3.6 Operation of HC-SR04 ultrasonic sensor

In order to generate the ultrasound, we need to set the Trig on a High State for 10 μ s. That will send out an 8 cycle sonic burst which will travel at the speed sound and it will be received in the Echo pin. The Echo pin will output the time in microseconds the sound waves traveled. For example, if the object is 10 cm away from the sensor, and the speed of the sound is 340 m/s or 0.034 cm/ μ s the sound wave will need to travel about 294 μ seconds. But what we will get from the Echo pin will be double that number because the sound waves needs to travel forward and bounce backward. So, in order to get the distance in cm we need to multiply the received travel time value from the echo pin by 0.034 and divide it by 2 as shown in **Fig. 3.7**

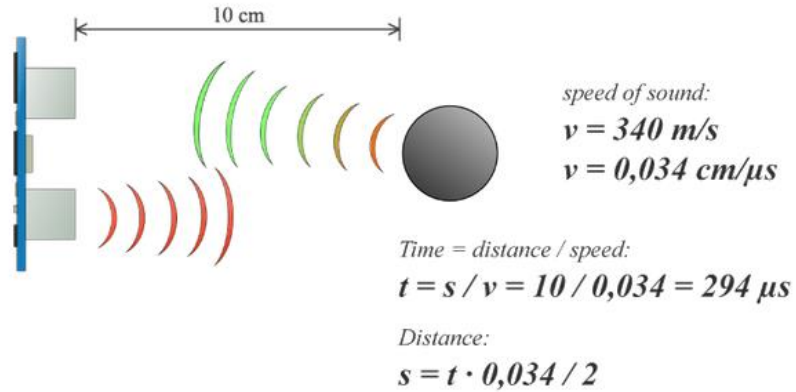

Fig. 3.7 Calculation of distance measurement

3.6 Buck Converter

The DC input can be derived from rectified AC or from any DC supply. A single 12-volt power source is added from where a parallel connection was taken to a buck converter which steps down 12 volts to 5 volts. Buck converter we used in this project is shown in **Fig. 3.8**.



Fig. 3.8 Buck converter

3.6.1 Operation

The buck converter circuit consists of the switching transistor, together with the flywheel circuit. While the transistor is on, current is flowing through the load via the inductor. The action of any inductor opposes changes in current flow and also acts as a store of energy. In this case the switching transistor output is prevented from increasing immediately to its peak value as the inductor stores energy taken from the increasing output; this stored energy is later released back into the circuit as a back EMF as current from the switching transistor is rapidly switched off.

3.7 LCD Display 16x2

LCD (Liquid Crystal Display) screen is an electronic display module and find a wide range of applications. A 16x2 LCD display is very basic module and is very commonly used in various devices and circuits [8]. These modules are preferred over seven segments and other multi segment LEDs. The reasons being LCDs are economical:

- Easily programmable
- Have no limitation of displaying special
- Even custom characters (unlike in seven segments), animations and so on.

A 16x2 LCD means it can display 16 characters per line and there are 2 such lines. In this LCD each character is displayed in 5x7 pixel matrix. This LCD has two registers- Command and Data [8].

3.7.1 Command Register

The command register stores the command instructions given to the LCD. A command is an instruction given to LCD to do a predefined task like initializing it, clearing its screen, setting the cursor position, controlling display etc. When $R_s=0$ command register is selected.

3.7.2 Data Register

The data register stores the data to be displayed on the LCD. The data is the ASCII value of the character to be displayed on the LCD. When $R_s=1$ data register is selected.

3.7.3 Rw(Read - Write)

Rw pin is used to read and write data to data and command registers. When $R_w=1$ we can read data from LCD. When $R_w=0$ we can write to LCD.

3.7.4 En (Enable signal)

When we select the register R_s (Command and Data) and set R_w (read - write) and placed the raw value on 8-data lines, now it's time to execute the instruction. By instruction it means the 8-bit data or 8-bit command present on Data lines of LCD. For sending the final data/command present on the data lines we use this enable pin. Usually it remains $en=0$ and

when we want to execute the instruction we make it high $en=1$ for some milliseconds. After this we again make it ground $en=0$.

3.7.5 V_0 (Set LCD contrast)

To set LCD display sharpness use this pin. Best way is to use variable resistor such as potentiometer a variable current makes the character contrast sharp. Connect the output of the potentiometer to this pin. Rotate the potentiometer knob forward and backward to adjust the LCD contrast. A 16x2 LCD display is shown in **Fig. 3.9**.

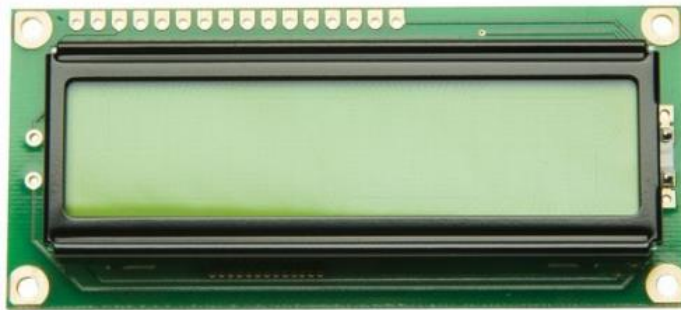

Fig. 3.9 16x2 LCD display [9]

3.7.6 Pin Diagram

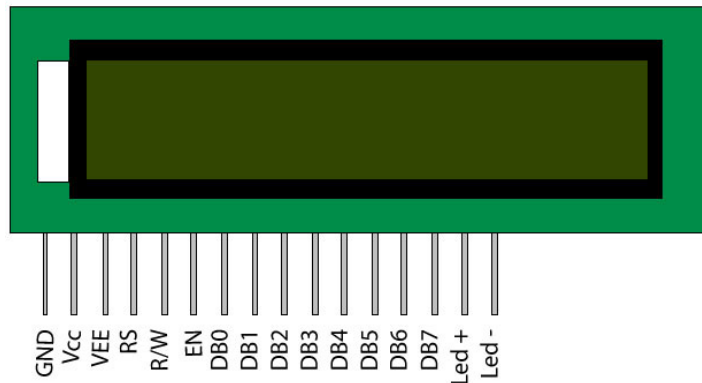

Fig. 3.10 Pin diagram of 16x2 LCD display [9]

Pin diagram of 16x2 LCD display is shown in **Fig. 3.10**.

3.7.7 Pin Description

Table 3.2 Pin description of 16x2 LCD display [10]

Pin No	Function	Name
1	Ground (0V)	Ground
2	Supply voltage; 5V (4.7V – 5.3V)	V _{CC}
3	Contrast adjustment; through a variable resistor	V _{EE}
4	Selects command register when low; and data register when high	Register Select
5	Low to write to the register; High to read from the register	Read/write
6	Sends data to data pins when a high to low pulse is given	Enable
7	8-bit data pins	DB0
8		DB1
9		DB2
10		DB3
11		DB4
12		DB5
13		DB6
14		DB7
15	Backlight V _{CC} (5V)	Led+
16	Backlight Ground (0V)	Led-

3.8 SPDT Switch

A single-pole, double-throw (SPDT) switch is as simple as it gets. SPDTs have three terminals: one common pin and two pins which vie for connection to the common. SPDTs are great for selecting between two power sources, swapping inputs or whatever it is we do with two circuits trying to go one place. Most simple slide switches are of the SPDT variety. SPDT switches should usually have three terminals [11]. **Fig. 3.11** Shows a SPDT switch circuit symbol and an SPDT slide switch.

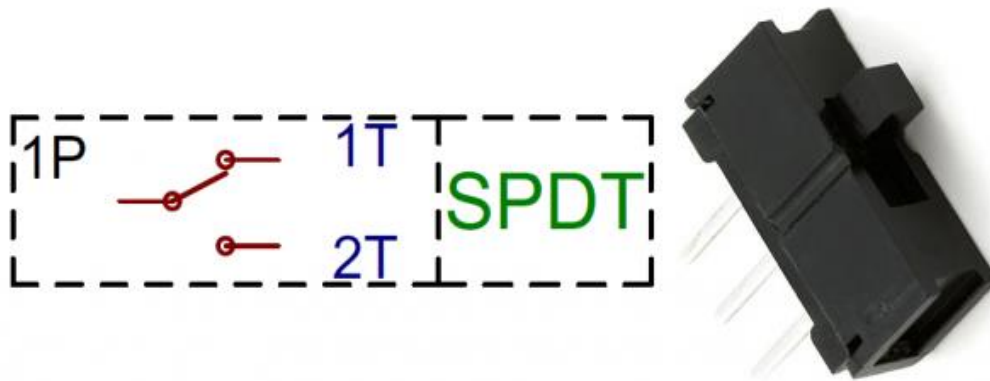

Fig. 3.11 SPDT switch circuit symbol and SSPDT slide switch [11]

3.9 BC547 Transistor

BC547 is an NPN transistor hence the collector and emitter will be left open (Reverse biased) when the base pin is held at ground and will be closed (Forward biased) when a signal is provided to base pin. BC547 has a gain value of 110 to 800, this value determines the amplification capacity of the transistor. The maximum amount of current that could flow through the Collector pin is 100 mA [12]. hence we cannot connect loads that consume more than 100 mA using this transistor. To bias a transistor, we have to supply current to base pin, this current (I_B) should be limited to 5 mA.

When this transistor is fully biased then it can allow a maximum of 100 mA to flow across the collector and emitter. This stage is called Saturation Region and the typical voltage allowed across the Collector-Emitter (V_{CE}) or Base-Emitter (V_{BE}) could be 200 and 900 mV

respectively. When base current is removed the transistor becomes fully off, this stage is called as the Cut-off Region and the Base Emitter voltage could be around 660 mV.

A BC547 Transistor pin out is shown in **Fig. 3.12**.

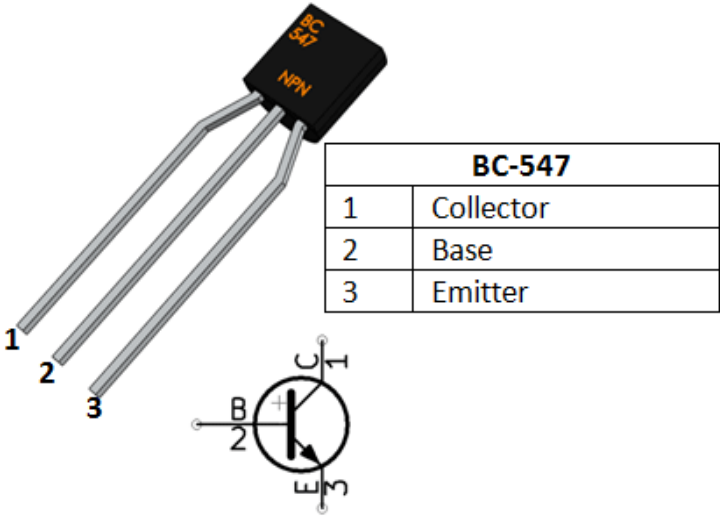

Fig. 3.12 BC547 transistor pinout [12]

3.9.1 Pin Configuration

Table 3.3 Pin configuration of BC547 transistor [12]

Pin Number	Pin Name	Description
1	Collector	Current flows in through collector
2	Base	Controls the biasing of transistor
3	Emitter	Current Drains out through emitter

3.9.2 Features

Features of BC547 transistor [12]. is given below:

- Bi-Polar NPN Transistor
- DC Current Gain (h_{FE}) is 800 maximum
- Continuous Collector current (I_C) is 100 mA
- Emitter Base Voltage (V_{BE}) is 6 V
- Base Current(I_B) is 5 mA maximum

3.10 Solar Panel (2 W)

A solar cell, or photovoltaic cell is an electrical device that converts the energy of light directly into electricity by the photovoltaic effect, which is a physical and chemical phenomenon. It is a form of photoelectric cell, defined as a device whose electrical characteristics, such as current, voltage, or resistance, vary when exposed to light. Solar cells are the building blocks of photovoltaic modules, otherwise known as solar panels. Solar cells are described as being photovoltaic, irrespective of whether the source is sunlight or an artificial light. They are used as a photo detector (for example infrared detectors), detecting light or other electromagnetic radiation near the visible range, or measuring light intensity [13]. The operation of a photovoltaic (PV) cell requires three basic attributes:

- The absorption of light, generating either electron-hole pairs or exactions.
- The separation of charge carriers of opposite types.
- The separate extraction of those carriers to an external circuit.

In this project we used a solar panel which is capable of 2 watts in the open sun with a peak power output around 6 V at 378 mA. The solar panel is shown in **Fig.3.13**.



Fig.3.13 Solar panel [13]

3.10.1 Specifications

- Mon crystalline cells - 19% efficient
- Peak Voltage: 6.0 V
- Peak Current: 0.33 A
- Peak Power: 2 Watts
- Waterproof Urethane Coating
- UV Resistant
- 110 mm x 136 mm x 3 mm

3.11 Resistor

A resistor is a passive two-terminal electrical component that implements electrical resistance as a circuit element [14]. In electronic circuits, resistors are used to reduce current flow, adjust signal levels, to divide voltages, bias active elements, and terminate transmission lines, among other uses. High-power resistors that can dissipate many watts of electrical power as heat, may be used as part of motor controls, in power distribution systems, or as test loads for generators. Fixed resistors have resistances that only change slightly with temperature, time or operating voltage. Variable resistors can be used to adjust

circuit elements (such as a volume control or a lamp dimmer), or as sensing devices for heat, light, humidity, force, or chemical activity. Resistors are common elements of electrical networks and electronic circuits and are ubiquitous in electronic equipment. Practical resistors as discrete components can be composed of various compounds and forms. Resistors are also implemented within integrated circuits.

In this project we have used resistors of different values. These are:

- 10 K variable resistor
- 10 K resistor
- 1 K resistor
- 1.8 K resistor
- 47 K resistor
- 100-ohm resistor
- 3.3 K resistor

3.12 Diode IN4007

A diode is a device which allows current flow through only one direction. That is the current should always flow from the Anode to cathode. The cathode terminal can be identified by using a grey bar. For 1N4007 Diode, the maximum current carrying capacity is 1 A it withstands peaks up to 30 A [15]. Hence we can use this in circuits that are designed for less than 1 A. The reverse current is 5 uA which is negligible [15]. The power dissipation of this diode is 3 W. An IN4007 diode is shown in **Fig. 3.14**.



Fig. 3.14 IN4007 diode [16]

3.12.1 Specifications

- Average forward current is 1 A
- Non-repetitive Peak current is 30 A
- Reverse current is 5 uA.
- Peak repetitive Reverse voltage is 1000 V
- Power dissipation 3 W

3.13 Crystal Oscillator

A crystal oscillator is an electronic oscillator circuit that uses the mechanical resonance of a vibrating crystal of piezoelectric material to create an electrical signal with a precise frequency. This frequency is often used to keep track of time, as in quartz wristwatches, to provide a stable clock signal for digital integrated circuits, and to stabilize frequencies for radio transmitters and receivers. The most common type of piezoelectric resonator used is the quartz crystal, so oscillator circuits incorporating them became known as crystal oscillators, but other piezoelectric materials including polycrystalline ceramics are used in similar circuits. A crystal oscillator, particularly one made of quartz crystal, works by being distorted by an electric field when voltage is applied to an electrode near or on the crystal. This property is known as electrostriction or inverse piezoelectricity [17]. When the field is removed, the quartz - which oscillates in a precise frequency - generates an electric field as it returns to its previous shape, and this can generate a voltage. The result is that a quartz crystal behaves like an RLC circuit. In this project we have used 8 MHz crystal oscillator which is shown in **Fig. 3.15**.



Fig. 3.15 8 MHz crystal oscillator [18]

3.13.1 Specifications

➤ Type	HC-49U
➤ Frequency	8 MHz
➤ Frequency Tolerance	±30 ppm
➤ Load Capacitance	20 PF
➤ Frequency Stability	± 2 ppm
➤ Mounting Type	DIP
➤ No. of Pins	2
➤ Pin Length	13 mm
➤ Size(Each)	26 x 11 x 4 mm/ 1" x 0.43" x 0.16" (L*W)
➤ Weight	48 g

3.14 Capacitor

A capacitor is a passive two-terminal electrical component that stores potential energy in an electric field. The effect of a capacitor is known as capacitance. While some capacitance exists between any two electrical conductors in proximity in a circuit, a capacitor is a component designed to add capacitance to a circuit. The capacitor was originally known as a condenser [19]. The physical form and construction of practical capacitors vary widely and many capacitor types are in common use. Most capacitors contain at least two electrical conductors often in the form of metallic plates or surfaces separated by a dielectric medium. A conductor may be a foil, thin film, sintered bead of metal, or an electrolyte. The non-conducting dielectric acts to increase the capacitor's charge capacity. Materials commonly used as dielectrics include glass, ceramic, plastic film, paper, mica, and oxide layers. Capacitors are widely used as parts of electrical circuits in many common electrical devices. Unlike a resistor, an ideal capacitor does not dissipate energy. In this project we have used 100nF and 1000uF 50V capacitor which is shown in **Fig. 3.16** and **Fig. 3.17** respectively.



Fig. 3.16 100 nF Capacitor [20]

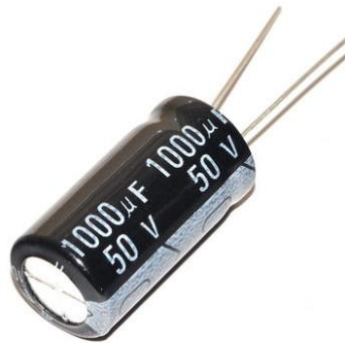

Fig. 3.17 1000 μ F Capacitor [21]

3.15 Block diagram of this project

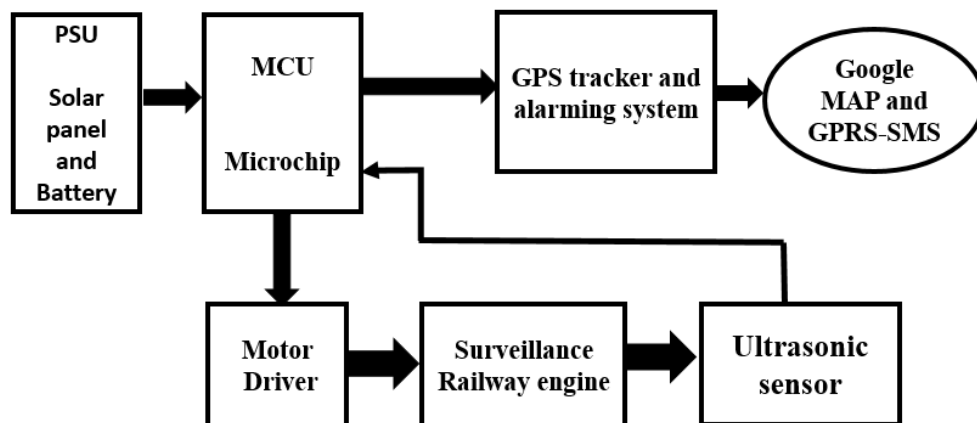

Fig. 3.18 Block diagram of solar based crack detection system using ultrasonic sensor

Here, this project powered by the solar panel. We used a PIC18F452 micro controller. Where, Ultrasonic Sensor is connected with the PIC18F452. Again, BC547 transistor connected with the MCU - PIC18F452 through the resistor. The BC547 is controlled the 9V DC Gear Motor. Basically, that is controlled by the relay and the motor get the power from solar panel. Again, SIM800L GSM Module, 2 line 16X2 LCD display, Buzzer are connected with the MCU - PIC18F452. In this project we have used a buck converter which basically increases the current level. This project perform the operation in the following manner. First of all ultrasonic sensor send a signal through the ECO and also received the upcoming signal through the ECO as well. If the depth greater than or equal 10 cm that time trigger occurs. When trigger occurs that time pin no 02 of MCU become low, pin no 16 become high and pin no 25 become high. Whenever pin no 2 become low that time BC457 goes into cutoff stage and motor become stopped. Similarly, when pin no 16 and 25 become high we heard a sound from the buzzer and GSM module search the fault location and that longitude & latitude send to the concerned authority. On the other hand if the depth less than 10 cm that time trigger will not occur. If trigger not occurred that time pin no 2 remain high and motor also remained on. Hence, buzzer will not give any sound and there is no information send to the concerned authority. In the following flow chart this operation has been shown-

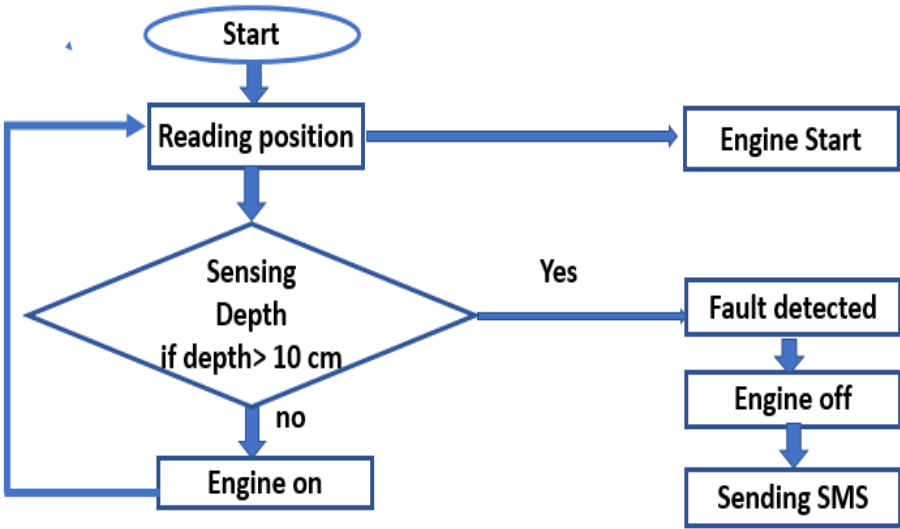

Fig. 3.20: Flow chart of the designed project

CHAPTER 4

RESULT AND DISCUSSION

4.1 Introduction

In this chapter, the outlook of the designed project and the result of the project have been discussed. In this chapter cost analysis of the project is also included.

4.2 Outlook of the designed prototype

We have captured some view of our build prototype. In this chapter, it has been included.

4.2.1 Side view of the project

In the following **Fig 4.1** the side of the project has been shown.

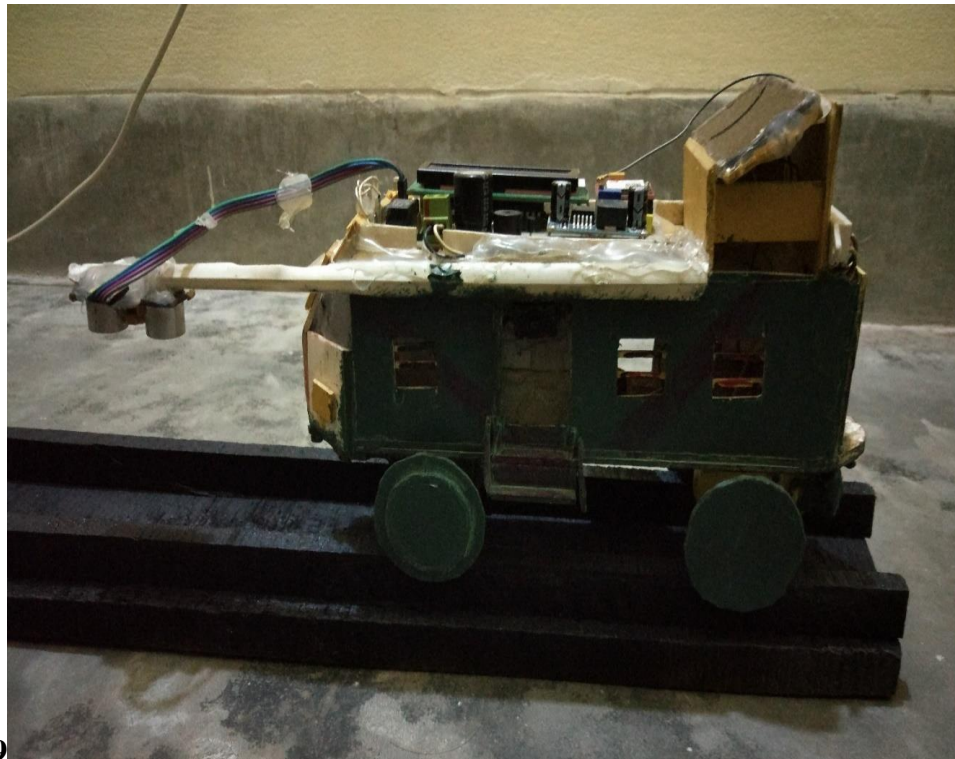

Fig 4.1: Side view of the project

4.2.2 Top view of the project

In the following **Fig 4.2** top view of the project has been shown.



Fig 4.2: Top view of the project

4.3 Results steps analysis:

In the result portion the steps of the project working principle is shown with figure in below. Before engine start first of all it will search the location which has been shown in below **Fig 4.3**.



Fig 4.3: Train ready for start and searching the location

Whenever the location has been detected that also shown in the display. From the below **Fig 4.4** it is quite clear.

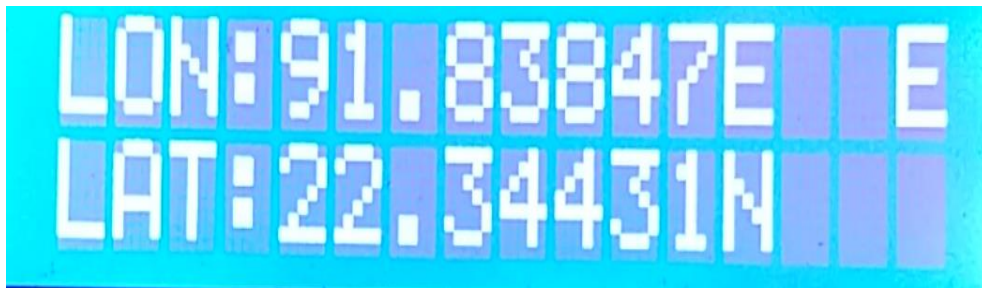

Fig 4.4: Detected current location has been shown in the display

GPS searching the longitude and latitude. After showing the location on the display the engine finally gets started that means moving on the track which also been shown in the following figure.

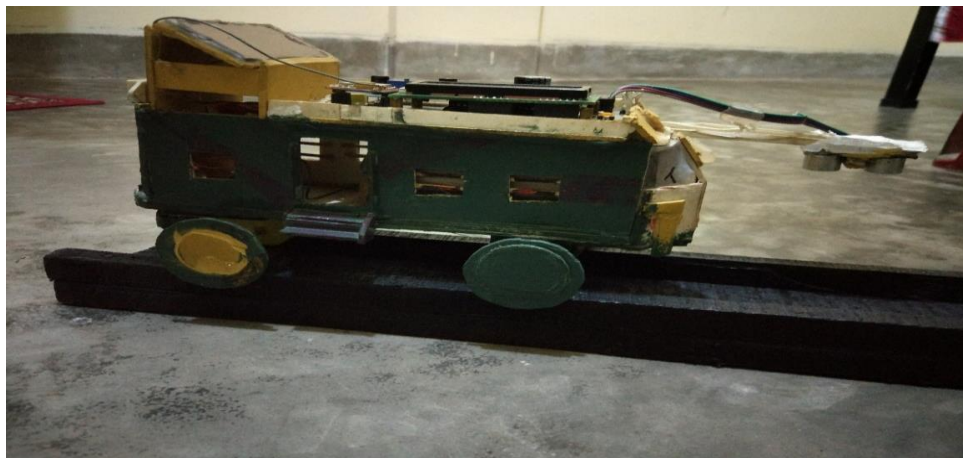

Fig 4.5: Train is moving on the track

In the above **Fig 4.5** train is moving on the track. It will move until there is no fault is detected on the track. We have selected a track which has fault to verify our project. In the below **Fig 4.6** the faulty track has been shown.



Fig 4.6: Faulty section of the track



Fig 4.7: Detecting fault and then searching for longitude and latitude

From the above **Fig 4.7:** it is clear that there is fault in the line. Whenever the ultrasonic sensor detected the fault in its range that start working based on the coded program. That

means when it finds the fault our system sending SMS to the concern authority. That also tested and the tested result has been shown in the below **Fig 4.8**.



Fig 4.8: Now, sending the SMS to the predefined number (Concern Authority)

When our system preparing SMS to send that time our system display show sending sms. That is clear from the above figure. Again whenever the SMS has been sent to the concerned authority time display will show “SMS sent” as like as following **Fig 4.9**.



Fig 4.9: SMS has been sent

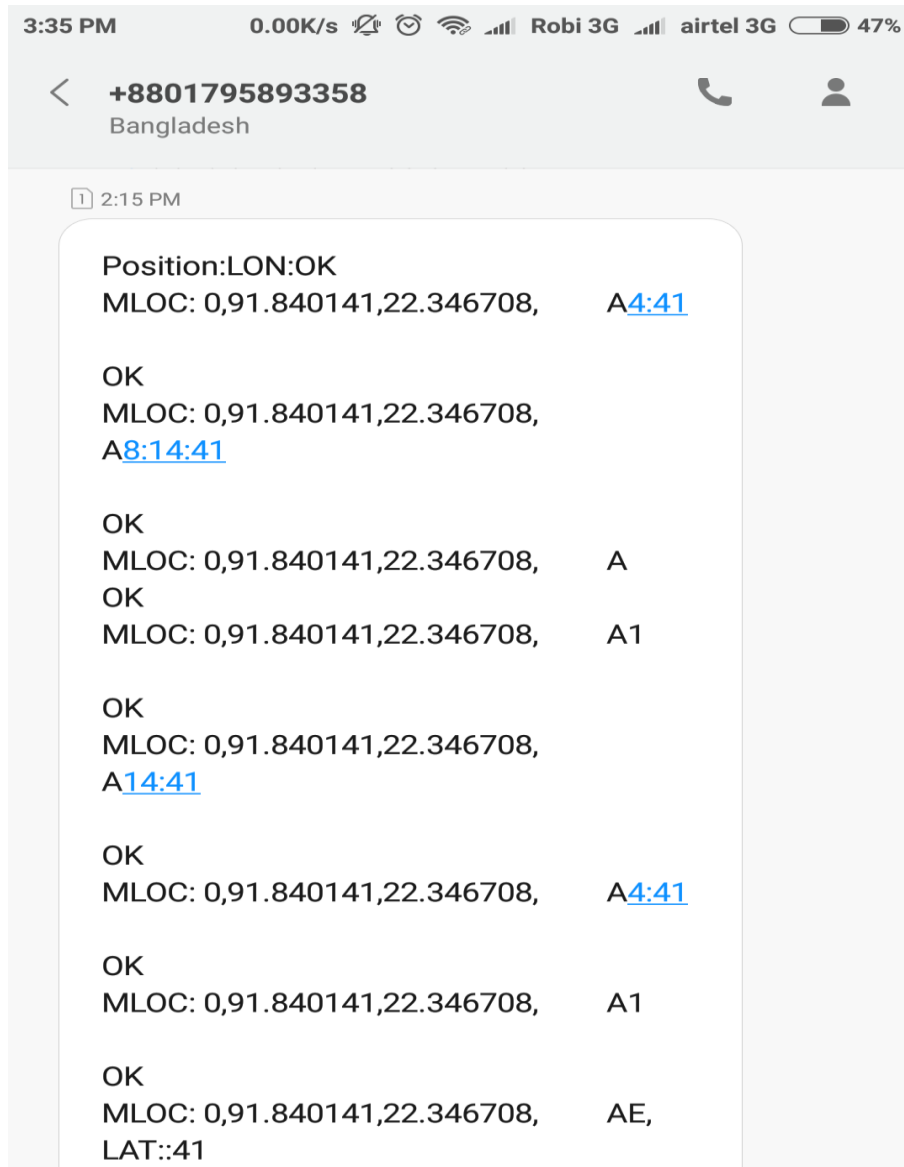

Fig 4.10: Received SMS by the concern authority

When the fault detected in the track then concerned authority will get a SMS as like as above **Fig 4.10**. That SMS basically carry the information of Longitude and Latitude of the faulty area of the track. Then based on the value of Longitude and Latitude authority can easily find out the location name from the Google MAP as like as following **Fig 4.11**.

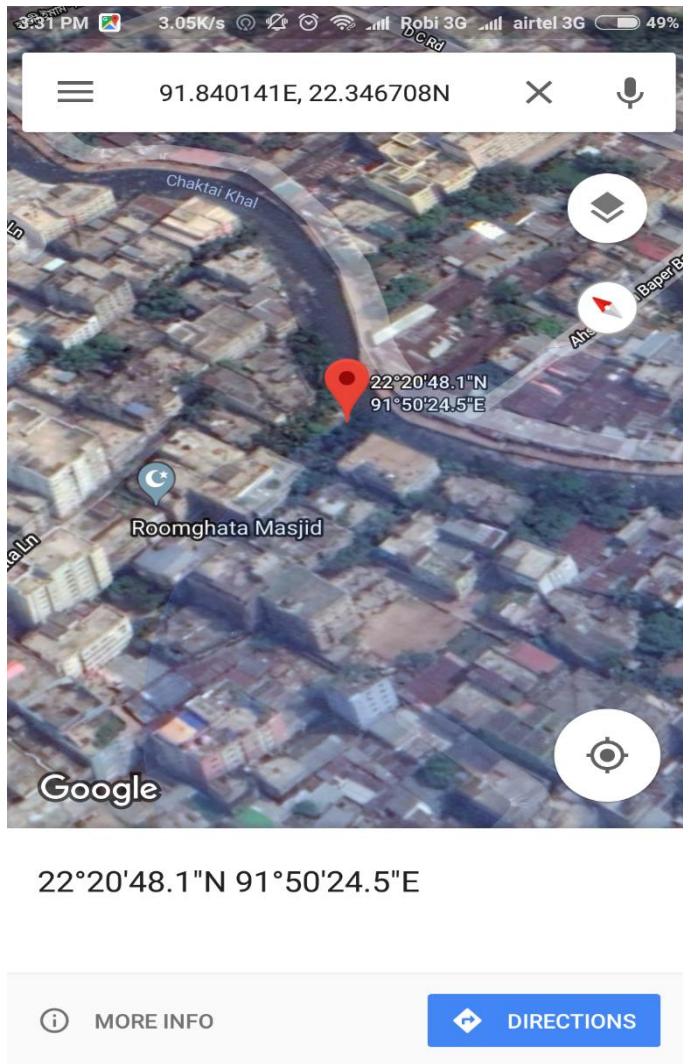

Fig 4.11: Based on the longitude and latitude location name in Google MAP

4.4 Cost analysis

In this section we have analyzed the cost of varies equipment which we have used in our project. We are used different brand equipment for this project. In this table we are also including the number of equipment. In the following **Table 4.1** the prize of the equipment is mentioned in BDT.

Table 4.1 Cost of the equipment's used in this project

Apparatus	Number	Price (BDT)
MCU-PIC118F452	1p	280
SIM800L GSM Module	1p	1500
Relay	1p	35
Ultrasonic Sensor	1p	180
LCD display (16X2)	1p	180
Transistor	1p	5
Buzzer	1p	10
Diode IN4007	6p	12
8MHZ Crystal	1p	15
SPDT Switch	2p	20
Buck Converter	1p	220
9V DC Gear Motor	1p	150
Solar Panel	1p	200
10k Variable Resistor	1p	5
100NF, 1000 μ F Capacitor	1p,1p	9
10K,3.3K,1K,47K,1.8K,100ohm	2p,1p,1p,1p,1p,1p	7
Cables, Hardware and Tools		300
Total		3,128

4.5 Advantage

1. Its cost very low compared to existing system.
2. Very accurate detection.
3. Transmitting signals are immediately transferred.
4. It also checks surface and near surface of the cracking position.
5. Accidents reduced.
6. System is powered by solar panel.
7. It is also environment friendly.

4.6 Limitation

1. Cracks lesser than 0.8 mm size cannot be detected.
2. If the cracks are propagating vertically downwards or upwards, detection is not possible.
3. It depended on sunlight.
4. It didn't give clear idea about fault.

4.7 Application

1. It is also possible to use in industry level like in heavy goods transferring railway track.
2. It is also possible to implement with our existing railway system of Bangladesh.

4.8 Discussion:

In this project, we have designed a solar based railway track crack detection system using ultrasonic sensor. In this project all function performed in the microchip. In the designed project we have done couple of test that has been included in the result section. The best part of this designed project it can easily detect the fault and immediately able to send the SMS to the concern authority. We have designed this project with help of solar panel which reduces the hazard of the power supply in the system because if we want to use battery that time it will become costly. In terms of cost, this project is very cheaper. However, since it is run with the solar power in bad weather condition it have some drawbacks.

CHAPTER 5

CONCLUSION AND FUTURE WORK

5.1 Conclusion

The proposed and designed solar-based railway crack detection system using ultrasonic sensor has been able to detect the crack of railway track, it has a great impact on the maintenance and monitoring of the track which helps in preventing train accidents with a very large extent and also able to save many lives. There are many advantages with the proposed system when compared with the existing detection techniques. It also includes many advantages such as less cost, low power consumption, less analysis time and accurate detection. Because of solar panel it also the system become environment friendly.

5.2 Future Improvement

In this project, we are using Ultrasonic sensor for detecting the cracks and obstacles in track. In future, we will also use the Close Circuit Television (CCTV) systems with IP based camera for monitoring the visual videos captured from track. It will also increase the security for the both rails and passengers.

REFERENCES

- [1] R. B. Mohd Razak, "Automatic Power Factor Correction," Universiti Teknikal Malaysia Melaka, 2009.
- [2] "automatic power factor controller circuit using microcontroller." [Online]. Available: <http://microcontrollerslab.com/automatic-power-factor-controller-using-pic-microcontroller/>. [Accessed: 01-Feb-2018].
- [3] "Power Factor Correction." [Online]. Available: <http://slideplayer.com/slide/10670638/>. [Accessed: 01-Feb-2018].
- [4] "Power Factor Correction Techniques." [Online]. Available: <https://www.mepits.com/tutorial/481/Electrical/Power-Factor-Correction>. [Accessed: 01-Feb-2018].
- [5] R. L. Boylestad, *Introductory circuit analysis*, 10th ed. Prentice Hall, 2003.
- [6] "Causes of low Power Factor." [Online]. Available: <https://www.electricaltechnology.org/2013/10/causes-of-low-power-factor.html>. [Accessed: 01-Feb-2018].
- [7] R. S. Biswas and S. Mal, "Automatic power factor improvement using microcontroller," *2015 Int. Conf. Work. Comput. Commun. IEMCON 2015*, 2015.
- [8] J. Ware, "Power Factor Correction (pfc)," *IEE Wiring Matters*, pp. 22–24, 2006.
- [9] "Advantages and disadvantages of Power factor improvement methods." [Online]. Available: <http://electricalengineeringtutorials.com/advantages-and-disadvantages-of-power-factor-improvement-methods/>. [Accessed: 01-Feb-2018].
- [10] "Power Factor improvement Methods with Their advantages & Disadvantages." [Online]. Available: <https://www.electricaltechnology.org/2013/10/power-factor-improvement-methods-with-their-advantages-disadvantages.html>. [Accessed: 01-Feb-2018].
- [11] M. H. O. Rashid, M. Hosain, S. Nur, T. Ahmed, and M. S. Islam, "Design and protective measures of a Power Factor Improvement (PFI) plant," Eastern University, 2012.
- [12] M. B. Khan, A. Wahab, T. Ahmed, and M. Campus, "Automatic Power Factor Correction Unit Automatic Power Factor Correction Unit," no. 1, 2015.
- [13] C. N. Jibhakate, M. A. Chaudhari, and M. M. Renge, "Power factor improvement using nine switch AC-DC-AC converter," *2016 IEEE 6th Int. Conf. Power Syst. ICPS 2016*, 2016.
- [14] T. G. Wilson, R. C. Wong, R. Wunderlich, and F. C. Lee, "A method for inductor core loss estimation in power factor correction applications," *Seventeenth Annu. IEEE Appl. Power Electron. Conf. Expo.*, vol. 1, no. c, pp. 439–445, 2002.
- [15] A.R.Yadav, S. S. Waghmode, G. B. Gawade, S. S. Zinjade, and P.T.Patil, "A Review on Microcontroller Based Automatic Power Factor Correction," *Int. J. Adv. Res. Electr. Electron. Instrum. Eng.*, vol. 5, no. 3, pp. 1517–1520, 2016.
- [16] S. S. Routray, "Microcontroller Based Automatic Power Factor Correction in Mines," National Institute of Technology, 2015.

- [17] M. S. Rana, M. N. Miah, and H. Rahman, "Automatic power factor improvement using microcontroller," *Glob. J. Res. Eng. Electr. Electron. Eng.*, vol. 13, no. 6, 2013.
- [18] "PIC18F452-I/P." [Online]. Available: <http://uk.farnell.com/microchip/pic18f452-i-p/ic-8bit-flash-mcu-18f452-pdip40/dp/9321357>. [Accessed: 01-Feb-2018].
- [19] "PIC 18F452 microcontroller." [Online]. Available: <http://techblog.pulkit.eu/pic>. [Accessed: 01-Feb-2018].
- [20] P. Dohrman, "What Are the Functions of a Current Transformer." [Online]. Available: <https://sciencing.com/functions-current-transformer-5347786.html>. [Accessed: 01-Feb-2018].
- [21] "ULN200x, ULQ200x High-Voltage, High-Current Darlington Transistor Arrays." [Online]. Available: <http://www.ti.com/lit/ds/symlink/uln2003a.pdf>. [Accessed: 01-Feb-2018].
- [22] Kushagra, "ULN2003 Datasheet." [Online]. Available: <https://www.engineersgarage.com/electronic-components/uln2003-datasheet>. [Accessed: 01-Feb-2018].
- [23] L. George, "USB PIC Programmer PICKit2." [Online]. Available: <https://electrosome.com/pickit2/>. [Accessed: 01-Feb-2018].

APPENDIX

```
// LCD module connections

sbit LCD_RS at RB3_bit;

sbit LCD_EN at RB2_bit;

sbit LCD_D4 at RD7_bit;

sbit LCD_D5 at RD6_bit;

sbit LCD_D6 at RD5_bit;

sbit LCD_D7 at RD4_bit;

sbit LCD_RS_Direction at TRISB3_bit;

sbit LCD_EN_Direction at TRISB2_bit;

sbit LCD_D4_Direction at TRISD7_bit;

sbit LCD_D5_Direction at TRISD6_bit;

sbit LCD_D6_Direction at TRISD5_bit;

sbit LCD_D7_Direction at TRISD4_bit;

// End LCD module connections

void Lcd_COut(char row, char col, const char *cptr)
{
    char chr = 0;          //first, it is used as empty string
    Lcd_Out(row, col, &chr); //nothing to write but set position.
    for ( ; chr = *cptr ; ++cptr ) Lcd_Chrcp(chr); //out in loop
}

void UART_Write_CText(const char *cptr)
{
    char chr;
    for ( ; chr = *cptr ; ++cptr ) UART1_Write(chr);
}

#define Buzzer RC1_bit
```

```

#define Relay RA0_bit

unsigned char text[64];

unsigned char Position[22];

int i = 0,j=0,k,l,a=0,distance;

char txt[4];

short ready = 0,read_ok=0;

void beep()

{

    Buzzer = 1;Delay_ms(50);Buzzer=0;Delay_ms(50);

}

if (RCIF_bit)

{

    // If interrupt is generated by RCIF

    text[i] = UART1_Read(); // Read data and store it to txt string

    i++; // Increment string index

    if (i >= 55)

    { // If index = 345,

        i = 0; // set it to zero

        ready = 1; // Ready for parsing GPS data

    }

    RCIF_bit = 0; // Set RCIF to 0

}

if(INTCON.RBIF == 1) //Makes sure that it is PORTB On-Change Interrupt

{

    INTCON.RBIE = 0; //Disable On-Change Interrupt

    if(PORTB.F5 == 1) //If ECHO is HIGH

        T1CON.F0 = 1; //Start Timer

```

```

    if(PORTB.F5 == 0)          //If ECHO is LOW
    {
        T1CON.F0 = 0;          //Stop Timer

        a = (TMR1L | (TMR1H<<2))*/22.12*/; //Calculate Distance
    }

    INTCON.RBIF = 0;          //Clear PORTB On-Change Interrupt flag
    INTCON.RBIE = 1;          //Enable PORTB On-Change Interrupt
}

}

void Read_Position(void)
{
    UART_Write_CText("AT\r\n");

    Delay_ms(500);Lcd_COut(1,16,"1");

    UART_Write_CText("AT+SAPBR=3,1,\"Contype\", \"GPRS\"\r\n");Delay_ms(500);Lcd_COut(1,16,"2");

    UART_Write_CText("AT+SAPBR=3,1,\"APN\", \"CMNET\"\r\n");Delay_ms(500);Lcd_COut(1,16,"3");
//
    UART_Write_CText("AT+SAPBR=1,1\r\n");Lcd_COut(1,16,"4");Delay_ms(500);

    for(i=0;i<22;i++)
    {
        text[i]=' ';//clear text   text[i]="\0";
    }

    Lcd_COut(1,16,"5");

    i = 0;

    ready = 0;

    RCIE_bit = 1;//enable interrupt

```

```

RCIF_bit = 0;//clear flag

//INTCON.RBIE = 0;

UART_Write_CText("AT+CIPGSMLOC=1,1\r\n");

Delay_ms(3000);Lcd_COut(1,16,"6");

if(ready == 1)

{
    // If the data in txt array is ready do:

    ready = 0;

    RCIE_bit = 0;//disable interrupt

    RCIF_bit = 0;//clear flag

    j = 0;

    for(i=0;i<64;i++)

    {

        if(text[i]=='0' && text[i+1]==',')

        {

            i = i+1;

            for(j=0;j<21;j++)

            {

                Position[j] = text[i];

                i++;

            }

            read_ok=1;

        }

    }

    if(read_ok==1)

    {

        Lcd_COut(1,1,"LON: ");

        Lcd_COut(2,1,"LAT:");
    }
}

```



```

    Delay_ms(2000);
}
void measure_distance()
{
    INTCON.RBIE = 1;
    INTCON.RBIF = 0;

    TMR1H = 0;           //Setting Initial Value of Timer
    TMR1L = 0;           //Setting Initial Value of Timer
    a = 0;
    RB4_bit = 1;        //TRIGGER HIGH
    Delay_us(10);       //10uS Delay
    RB4_bit = 0;        //TRIGGER LOW
    Delay_ms(100);      //Waiting for ECHO
    a = a/58.82 + 1;     //Error Correction Constant
    distance = a;
    if(a>2 && a<400)    //Check whether the result is valid or not
    {
        IntToStr(a,txt);
        Ltrim(txt);
        Lcd_Out(1,1," "); beep();
        Lcd_Out(1,1,"Distance = ");
        Lcd_Out(1,12,txt);
        Lcd_Out(1,15,"cm");
    }
    else
    {
        Lcd_Out(1,1," Out of Range ");
    }
}

```

```

    }
}
void main()
{
    TRISA = 0x00;//all output
    TRISB = 0b11100000;//all input
    TRISC = 0x00;
    TRISE = 0x00;//all output
    ADCON0 = 0x00;
    ADCON1 = 0x07;
    NOT_RBPU_bit = 0;
    Relay = 0;
    Lcd_Init();
    Lcd_Cmd(_LCD_CLEAR);
    Lcd_Cmd(_LCD_CURSOR_OFF);
    Lcd_COut(1,1,"Ultrasonic &");
    Lcd_COut(2,1,"A-GPS Position");
    UART1_Init(9600); beep();
    Delay_ms(5000);
    GIE_bit = 1; // Enable Global interrupt
    PEIE_bit = 1; // Enable Peripheral interrupt
    RCIE_bit = 1; // Enable USART Receiver interrupt
    RCIF_bit = 0;//clear flag
    INTCON.RBIF = 0;          //Clear PORTB On-Change Interrupt Flag
    INTCON.RBIE = 1;         //Enable PORTB On-Change Interrupt
    T1CON = 0x10;
    UART_Write_CText("AT\r\n");
    Delay_ms(200);

```

```

Lcd_Cmd(_LCD_CLEAR);

/*Lcd_COut(1,1,"LON:00.00000E");

Lcd_COut(2,1,"LAT:00.00000N");*/

while(1)

{

    RCIE_bit = 0;//disable RCIF

    RCIF_bit = 0;//clear flag

    OERR_bit = 0;// clear Overrun Error bit

    FERR_bit = 0;//clear Farming Error bit

    Lcd_COut(1,1,"Reading A-GPS")

    Lcd_COut(1,16,"R");

    Read_Position(void);

    Lcd_COut(1,16,"E");

    Delay_ms(2000);

    Lcd_Cmd(_LCD_CLEAR);

    UART_Write_CText("AT\r\n");

    measure_distance();

    Delay_ms(2000);

    Lcd_Cmd(_LCD_CLEAR);

    if(distance>30)

    {

        Lcd_COut(1,1,"Sending SMS") ;beep();beep();

        Relay = 1;

        Send_SMS_Int(void);

```

