



**BACHELOR OF SCIENCE IN ELECTRONICS AND TELECOMMUNICATION  
ENGINEERING**

**Design and Simulation of a High Gain and High Band  
Microstrip Patch Antenna with SAR Analysis for 5G  
Wireless Communications**

Submitted by

**Prosenjit Mazumder**

T-161013

Supervised by

**Engr. Syed Zahidur Rashid**

Assistant Professor

Department of ETE

International Islamic University Chittagong

Department of Electronics and Telecommunication Engineering

International Islamic University Chittagong

Kumira, Sitakunda, Chattogram-4318

January, 2021

## **DEDICATION**

This research work is dedicated to all honorable and respectable departments' teachers.

## **CANDIDATES DECLARATION**

It is hereby declared that this research project has not been accepted else anywhere for thesis work or diploma work and this doesn't contain any unlawful statements.

---

Prosenjit Mazumder

T-161013

## **Acknowledgements**

In the name of Allah, the most merciful and the most gracious. All praises to Allah (SWT) that he blesses us a lot and keeps us healthy to do the work with pleasant and kept our mentality strong to reach the work to final. I express my warm gratitude and happiness to my honorable Supervisor and Head, Dept. of ETE, IIUC **Engr. Syed Zahidur Rashid** for his initiative in this field of research, valuable guidance, encouragement throughout the time of research. We also express our thankfulness to him for providing us with best facilities in the department and his timely suggestions. We are also thankful to **Mostafa Amir Faisal**, Convener of our thesis for his dedication and sacrifice. We also express our sincere gratitude to our entire teacher for giving us the best effort throughout our entire academic years. And we remember our parents for their support in our life till now. And we also express gratitude our friends, well-wishers for their directly or indirectly involvement in the completion of this thesis work.

## **Abstract**

This paper specified the range and application of design parameters for 5G antenna requirements. In designing microstrip patch antenna [MPA], three parameters namely as antenna gain, antenna bandwidth and feeding technique have significantly effect on the performance of antenna result parameters. If these are not suitably chosen, then the 5G application requirement will not cover. This work specified the three parameters for designing MPA which is fulfill the 5G application requirement. In addition, a comparative analysis of antenna performance is done based on these three designing parameters. Moreover we have found that partial ground plane technique for wide bandwidth and air substrate for high gain and simulated the proposed antenna at operating frequency 28 GHz. The gain, bandwidth, return loss, VSWR and efficiency of the designed antenna at 28 GHz are 11.5 dBi, 18 GHz, - 13 dB, 1.002, 93% respectively. After that, SAR value was calculated and tested the proposed antenna of the radiation effect by modelling the human brain and found that 0.348 W/kg which is less than 2 W/kg and safe from the radiation effect for future upcoming higher frequencies communication.

# TABLE OF CONTENTS

## Table of Contents

DEDICATION.....	ii
CANDIDATE DECLARATION .....	iii
ACKNOWLEDGEMENTS .....	iv
ABSTRACT .....	v
TABLE OF CONTENTS .....	vi
LIST OF FIGURES .....	x
LIST OF TABLES.....	xii
LIST OF SYMBOLS.....	xiii
LIST OF ABBREVIATIONS.....	xiv
<b>Chapter 1: Introduction.....</b>	<b>1</b>
1.1 Evolution of Wireless Communication.....	1
1.2 Zero Generation Wireless Technology (0G).....	1
1.3 First Generation Wireless Technology (1G).....	2
1.3.1 Key features (technology) of 1G system.....	3
1.3.2 Disadvantages of 1G system.....	4
1.4 Second Generation Wireless Technology (2G).....	4
1.4.1 Key features of 2G system.....	5
1.5 GPRS (General Packet Radio Service) 2.5G.....	5
1.6 Third Generation Wireless Technology (3G).....	6
1.6.1 Key features of 3G system.....	7
1.7 Fourth Generation Wireless Technology (4G).....	8
1.7.2 Disadvantages of 4G system.....	10
1.8 Fifth Generation Wireless Technology (5G).....	10
1.8.1 Features of 5G [1].....	11

1.9 Final thoughts .....	11
1.10 Global 5G spectrum update.....	12
1.10.1 The FCC is driving key spectrum initiatives to enable 5G.....	13
1.10.2 Low-band .....	13
1.10.3 Mid-band .....	13
1.10.4 High-band.....	13
1.10.5 High-band: Spectrum Frontiers governing for 5G mmWave bands .....	14
1.10.6 5G Spectrum in Europe .....	13
1.11 Antenna Basics.....	14
1.11.1 Frequency .....	14
1.11.2 Bandwidth .....	16
1.11.3 Input Impedance .....	16
1.11.4 Impedance Matching .....	17
1.11.5 Directivity and Gain .....	17
1.11.6 Radiation Pattern .....	18
1.11.7 Voltage Standing Wave Ratio (VSWR).....	19
1.11.8 Return Loss (RL).....	20
1.11.9 Polarization.....	20
1.12 Microstrip Antenna .....	21
1.12.1 Microstrip Line Feeding.....	22
1.12.2 Advantages and Disadvantages of Microstrip Antenna.....	22
1.13 Design Tool.....	23
1.13.1 CST Microwave Studio .....	23
1.14 Motivation.....	23
1.15 Essence.....	24

<b>Chapter 2: Literature Review</b> .....	<b>26</b>
2.1 Overview of “Release 15 on 5G Standards” Update by 3GPP .....	26
2.2 Paper Review .....	27
2.3 Summary .....	37
2.4 Objectives .....	37
<b>Chapter 3: Methodology</b> .....	<b>38</b>
3.1 Methodology .....	38
3.2 Research Design.....	38
3.3 Pilot Study.....	39
3.4 Software .....	39
3.5 Design procedure .....	40
3.5.1 Antenna Substrates .....	40
3.5.2 Antenna Design by Equation.....	41
3.5.3 Radiating patch.....	41
3.5.4 Feed-line.....	42
3.5.5 Partial Ground Plane.....	44
3.5.6 SAR Concept and Human Brain Model.....	44
<b>Chapter 4: Simulations and Results’ Analysis</b> .....	<b>46</b>
4.1 Simulation Results of Proposed Single Band Antenna.....	46
4.1.1 Return Loss Graph .....	46
4.1.2 VSWR Plot.....	47
4.1.3 2D Radiation Pattern .....	47
4.1.4 3D Radiation Pattern.....	48
4.1.5 Antenna Efficiency and Radiation Efficiency.....	49
4.1.6 Gain versus frequency Plot.....	49
4.2 SAR Calculation result.....	50
4.2.1 Radiation Effect on Human Brain.....	50
4.2.2 Result of Final Proposed Antenna.....	51
4.2.3 Comparison with the Existing 28 GHz Single Band Antenna.....	51

<b>Chapter 05: Conclusion</b> .....	<b>52</b>
5.1 Achievements.....	52
5.2 Limitations.....	53
5.3 Future Work.....	53
<b>References</b> .....	<b>54</b>

## LIST OF FIGURES

Figure 1.1: Evolution/Enhancement of communication [4] .....	2
Figure 1.2: 3G vs 2G Communication [4] .....	7
Figure 1.3: 4G cell phone generation compared [4] .....	8
Figure 1.4: Global 5G spectrum [6-7].....	12
Figure 1.5: 5G spectrum [6-7] .....	13
Figure 1.6.: Frequency diagram .....	16
Figure 1.7: High frequency and Low frequency diagram.....	16
Figure 1.8: Bandwidth diagram .....	18
Figure 1.9: Directivity and Gain .....	20
Figure 1.10: Radiation pattern .....	21
Figure 1.11. VSWR.....	22
Figure 1.12: Polarization Linear, Circular, Elliptical [12-9] .....	23
Figure 1.13: Structure of a Microstrip Patch Antenna [12-9].....	24
Figure 1.14: Microstrip Line Feeding [11-7] .....	25
Figure 1.15: Coaxial / Probe feeding [11-7] .....	25
Figure 1.16: Aperture-Coupled Feed [11-7] .....	26
Figure 1.17: Proximity-Coupled Feed [11-7] .....	26
Figure 2.1: Allocated Frequency bands in different locations [8-11].....	33
Figure 3.1: Insert Feedline design.....	55
Figure. 3.2: Antenna back view .....	55
Figure. 3.3: Partial ground plane.....	56

Figure. 3.4: Human Brain layout its model properties.....	57
Figure. 3.5: Antenna layout with human brain model .....	58
Figure. 4.1. Return Loss Plot at 28 GHz.....	59
Figure 4.2.VSWR Plot .....	60
Figure. 4.3. 2D Radiation Pattern .....	61
Figure. 4.4 3D Radiation Pattern .....	61
Figure. 4.5. Efficiency Plot at 28 GHz.....	62
Figure. 4.6. Gain Vs Frequency Plot.....	62
Figure.4.7. SAR Calculation Result at 28 GHz .....	63
Figure.4.8. Power Loss at 28 GHz.....	63

## LIST OF TABLES

Table 1.1 generation of communication .....	11
Table 2.1. Technical requirements of 5g.....	31
Table 2.2. Defferences between LTE and NR.....	32
Table 2.3. Frequencies of interest in several location .....	33
Table 3.1 List of substrates .....	53
Table 3.2 Design Antenna Parameters .....	56
Table 3.3 Partial ground plane parameters.....	56
Table 3.4 Total Simulation Results of the proposed antenna .....	64
Table 3.5 Comparison Table .....	64

## LIST OF SYMBOLS

Hz	Hertz
KHz	Kilo Hertz
MHz	Mega Hertz
GHz	Giga Hertz
mm	Millimeter
cm	Centimeter
m	Meter
$\epsilon$	Relative permittivity
L	Length
W	Width
C	Speed of light
dB	Decibel
$\lambda$	Lambda
$\Omega$	Ohm
$\epsilon_r$	Dielectric Constant

## LIST OF ABBREVIATIONS

RT	Duroid 5880
IEEE	Institute of Electrical and Electronic Engineers
LTE	Long Term Evolution
5G	Fifth Generation
1G	First Generation
2G	Second Generation
3G	Third Generation
4G	Fourth Generation
FCC	Federal Communication Commission
SDR	Software Define Ratios
GSM	Global System for Mobile Communication
3D	Three Dimension
2D	Two Dimension
VSWR	Voltage Standing Wave Ratio
WCC	Wireless Communication Centre
IE3D	Moment of Method Based EM Simualtor
HFSS	High Frequency Structure Simualtor
PCB	Printed Circuit Board
BW	Bandwidths

RL	Return Loss
Q	Quality Factor
RF	Radio Frequency
MICs	Microwave Integrated Circuits
PTT	Push to Talk
IMTS	Improved Mobile Telephone System
AMTS	Advance Mobile Phone System
FDMA	Frequency Division Multiple Access
TDMA	Time Division Multiple Access
CDMA	Code Division Multiple Access
GPRS	General Packet Radio Service
MIMO	Multiple Input Multiple Output

# Chapter 1

## Introduction

### 1.1 Evolution of Wireless Communication

Mobile wireless communication system has had many evolution stages within the past few decades once the introduction of the first-generation mobile network in early Nineteen Eighties. because of vast demand for additional connections worldwide, mobile communication standards advanced quickly to support additional users [1].

Wireless communication, or generally merely wireless, is that the transmission of knowledge between 2 or additional points that don't seem to be connected physically. electromagnetic wave is employed within the commonest wireless technologies. In communications history, the term wireless has been used double, with a touch completely different that means. it had been primarily used from around 1890 for the primary electromagnetic wave transmission and receiving technology, as in wireless telegraphy, till the new word radio replaced it in 1920. The term was revived within the Nineteen Eighties and Nineteen Nineties decade primarily to tell apart digital devices that were ready to communicate while not wires. Wireless operations give services, like long-distance communications, that don't seem to be attainable or possible to implement with the employment of wires [2]. Evolution of communication shown in figure one.1. Let's take a glance on the evolution stages of wireless technologies for mobile communication.

### 1.2 Zero Generation Wireless Technology (0G)

Wireless phone started with 0G, which could have known as Zero Generation, became accessible when the globe War-II. At that point, there have been solely a restricted variety of communication channels on the market and mobile operators found out the calls. These mobiles couldn't support the feature of relinquishing suggests that amendment of channel frequency whereas moving. Zero generation refers to the pre cellular mobile system within the early 1970's. as an example, some subscribers had Radio telephones in cars before the introduction of cell phones. Mobile radio telecommunication system produced modern cellular mobile-

telephone technology. These systems are called 0G (Zero Generation) Systems. Since they were predecessors of first generation of cellular telephones.

Technologies utilized in Zero Generation systems enclosed Push to speak (PTT), Mobile phone system (MTS), Improved Mobile public utility (IMTS), Advanced Mobile phone system (AMTS), Norwegian offensive Land-Mobil phonephone (OLT), PublicLandMobile telecommunication (PLT)andSwedishMobile telecommunication System D (MTD). The users of the system were loggers, construction supervisors, realtors and celebrities. The communication system was used for the aim of solely oral communication [3].



Figure 0-1.1 Evolution/Enhancement of communication [4]

### 1.3 First Generation Wireless Technology (1G)

1G is that the first-generation wireless phonephone technology supported analog signal. They were introduced in 1980 and were known as analog cell phones. Nippon phonephone and Telegraph (NTT) introduced the primary cellular system within the world that became operational in national capital, Japan in 1979. the foremost standard analog systems in Europe were Nordic Mobile phonephone (NMT) and Total Access Communication System (TACS). at the side of these 2 systems, another technical company introduced analog systems in 1980's in Europe. However, the cellular networks systems weren't ready to interoperate between countries, offered relinquishing and roaming capability [5].

The key drawback of First-Generation mobile technology is that the failure to interoperate between totally different countries. Additionally, 1G has alternative drawbacks like low capacity-unreliable football play system, poor voice links. Also, there was no security since voice calls were accustomed replay in wireless towers creating these calls liable to undesirable persons. the primary 1G customary in USA was AMPS, launched in 1982. Federal Communication Commission (FCC) allotted a forty megahertz channel inside the 800-900 megahertz frequency vary for this technique. AMPS was allotted a supplementary ten megahertz information measure, known as enlarged spectrum (ES) in 1988.

Italy, France and UK used communication systems known as RTMI, RadioComm and YACS severally. A telecommunication customary branded as C-450 was introduced in European nation, Portuguese Republic and African country. initial Generation system replaced 0G system, whose options includes mobile radio telephones and technologies as Advanced Mobile phone system (AMTS), Mobile phone system (MTS), Push to speak (PTT), and Improved Mobile public utility (IMTS).

- Established in 1980s and finalized in early 1990s
- Supported data transfer speed up to 2.4 kbps
- Advance mobile phone system (AMPS) was first introduced by the USA and is a first-generation mobile system.
- It permits the users to initiate voice calls within only one country [5].

### 1.3.1 Key features (technology) of 1G system

- Frequency 800 MHz and 900 MHz
- Bandwidth: 10 MHz (666 duplex channels with bandwidth of 30 KHz)
- Technology: Analogue switching
- Modulation: Frequency Modulation (FM)
- Mode of service: voice only
- Access technique: Frequency Division Multiple Access (FDMA)

### 1.3.2 Disadvantages of 1G system

- Poor voice quality due to interference
- Poor battery life
- Large sized mobile phones (not convenient to carry)
- Less security (calls could be decoded using an FM demodulator)
- Limited number of users and cell coverage
- Roaming was not possible between similar systems [1]

## 1.4 Second Generation Wireless Technology (2G)

2G is that the Second-Generation wireless network, established on digital technologies put in in Nineteen Nineties. 2G was introduced in Suomi in 1991. It provided services as an example Short Message System (SMS), image messages and transmission Message System (MMS). As in 2G, text messages and audio signals are digitally encoded, which allows for the transmission of knowledge in such how that solely desired receiver will receive and decipher it. 2G provides larger security for each sender and receiver. To compress and multiplex Digital signal CODEC (compression decompression algorithm) is employed in 2G. TDMA and CDMA were used as digital multiple access technology in 2G system. TDMA splits signal in time slots whereas CDMA assigns every user a definite code to speak over a multiplexed channel. TDMA technologies includes international System for Mobile Communications (GSM), Personal Digital Cellular (PDC) IS-136, and iDEN within the Digital increased conductor Telecommunications(DECT) commonplace for moveable mobile phones. GSM was the primary 2G System. it's the foremost appreciated mobile commonplace of all mobile wireless technologies deployed in around 212 countries within the world.

International roaming between totally different mobile operators was introduced 1st by GSM technology that permits the users to use their mobile phones in several countries. TDMA technology is employed in GSM to multiplex up to eight calls per channel within the 900 megacycle per second and 1800 megacycle per second frequency bands. It delivers voice signals along side circuit switched knowledge at speed up to fourteen.4 kbps. Federal Communications Commission additionally auctioned a brand new block of

spectrum within the 1900 megacycle per second band within the USA. Throughout last twenty years, this technology has been perpetually developed to supply higher services. Some new technologies are industrialised supported the first GSM, outstanding to some advanced system, known as two.5 generation (2.5 G) Systems [5].

#### **1.4.1 Key features of 2G system**

- ❑ Digital system (switching)
- ❑ SMS services is possible
- ❑ Roaming is possible
- ❑ Enhanced security
- ❑ Encrypted voice transmission
- ❑ First internet at lower data rate
- ❑ Disadvantages of 2G system
- ❑ Low data rate
- ❑ Limited mobility
- ❑ Less features on mobile devices
- ❑ Limited number of users and hardware capability [1]

### **1.5 GPRS (General Packet Radio Service) 2.5G**

2.5G, stands for “second and half generation”, is a mobile wireless standard developed in the middle of its predecessor second generation and its successor third generation. The expression “second and half generation” is applied to define the “General Packet Radio Services”. GPRS can provide the data rate around 56 Kbit/s to 115 Kbits/s as peak. It supports facilities such as Access Multimedia Messaging Services (AMMS), Wireless Application Protocol (WAP), and internet facilities including Email and World Wide Web (WWW) access. The charge for data transfer in GPRS is typically in megabyte of traffic conveyed, but in data communication through conventional circuit switching is billed each minute of linking time [5].

## 1.6 Third Generation Wireless Technology (3G)

Telecommunication standards cluster 3G is employed to outline the third generation of wireless communication standards, paramount a pair of 5G, and preceding 4G. International Telecommunication Union (ITU) framed a concept to use the worldwide band of 2000 megahertz, which is {able to} be able to support one, present wireless network commonplace for all countries within the world. The setup is understood as “International Mobile phone 2000” or IMT-2000 commonplace. There square measure 3 variety of multiple access technology-

CDMA 2000: it's planned by North America wireless Telecommunication standards teams supported Code Division Multiple Access technology. Its channel breadth is one.25 megahertz and speed square measure up to a hundred and forty four Kbps.

WCDMA (UMTS): WCDMA service FOMA was launched by NTT Do Como in Japan for the primary time within the world commercially in 2001. it's careful as band Code Division Multiple Access. Its channel breadth is five megahertz and speed square measure up to 2 Mbps.

TD-SCDMA: China wireless Telecommunication standards cluster planned the Time Division Synchronous Code Division Multiple Access technology to be used in 3G [5]. Third Generation Partnership Project (3GPP) has continuing that project by formulating a wireless system that achieves the specification of IMT-2000 standards.

The third generation or 3G wireless technology came into services within the year of 2000. Previous technology supported knowledge transmission speed of 144Kbps as peak whereas 3G has increased it to a pair of Mbps. sensible phone or transmission telephone is needed to urge services of 3G technology. Information measure and knowledge transfer rate were increased in 3G to facilitate web-based application, audio, and video files.

Network operators are enabled to offer their users a broader range of more progressive facilities by achieving better network capacity through enhanced spectral efficiency with the deployment of 3G technologies. 3G system services comprises of wide area wireless voice.

Conferencing, entirely in a portable wireless environment. Figure 1.2 shows 3G vs 4G communication.

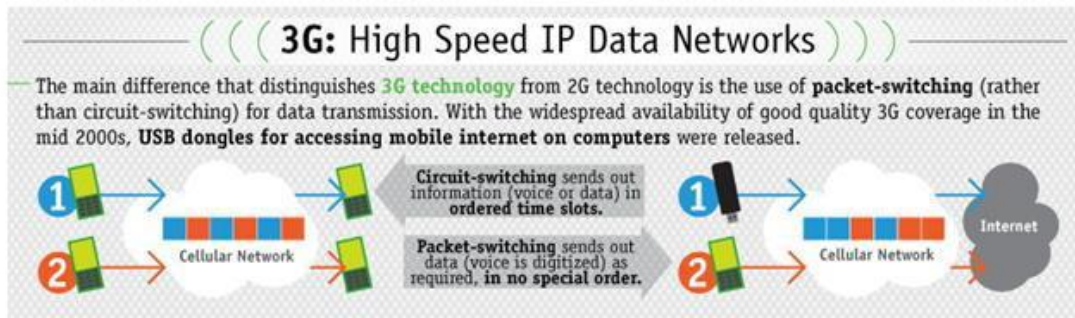

Figure 0-2Figure 1.2: 3G vs 2G Communication [4]

This network has the improvements over 2.5G network and previous given below [5]:

- Numerous times higher data transfer speed.
- Upgraded audio and video streaming
- Video conferencing facility
- greater speed in WAP and Web browsing
- IPTV (TV through the Internet) support

### 1.6.1 Key features of 3G system

- Higher data rate
- Video calling
- Enhanced security, a greater number of users and coverage
- Mobile app support
- Multimedia message support
- Location tracking and maps
- Better web browsing
- TV streaming
- High quality 3D games [1]

## 1.7 Fourth Generation Wireless Technology (4G)

The main concept of 4G is inter-operability between diverse categories of networks, to provide high speed data transfer rate for example 100 Mbps as the peak data rate for both the server and the data receiver which are moving at a speed of 60 Km/h. And the data transfer rate should be a maximum of 1 Gbps when the server and the receiver are stationary [5].

	Standards	Technology	SMS	Voice Switching	Data Switching	Data Rates
1G	AMPS, TACS	Analog	No	Circuit	Circuit	N/A
2G	GSM, CDMA, EDGE, GPRS	Digital	Yes	Circuit	Circuit	236.8 kbps
3G	UTMS, CDMA2000, HSPDA, EVDO	Digital	Yes	Circuit	Packet	384 kbps
4G	LTE Advanced, IEEE 802.16 (WiMax)	Digital	Yes	Packet	Packet	up to 1 Gbps

Figure 0-3 Figure 1.3. 4G cell phone generation compared [4]

Currently deployed mobile networks standards are 4G that have replaced third generation networks in many countries. In other context, 4G is just an initiative by academics and research and developments labs to cope with the limitations and difficulties of 3G, which is having trouble being deployed, and able to meet its predefined performance and throughput. Now we can access the internet by using our cell phone with the assistance of various technologies, like Wi-Max, Wi-Fi, WAP, GPRS, EDGE and Wi-Bro in 3G.

But the users are facing problem when they have to access the internet through the cell phone by using any of these described technologies, the user is stuck when they travel to place where inter-operability in the middle of different networks attains. When using 4G, the users are able to access the network using any of the previously mentioned technologies even though travelling from one place to another. The issues that are considered to be resolved in 4G mobile network are as below:

1. As per high data transfer rates are send and receive through the phone 4G wireless technology has inserted IP feature in the mobile phone for enhanced security purpose.
2. In fourth generation wireless standard, the users can download at a data rate of 100 Mbps in mobile access and in case of stationary 1Gbps for local access of mobile network.

3. OFDMA is a new technology introduced in 4G in place of hybrid technology deployed in 3G with the mixture of IS-95 and CDMA. OFDMA is more efficient than previous TDMA or CDMA.
4. In OFDMA, data are sent by allocating the channel into a narrow band for better efficiency which is an outstanding feature of fourth generation wireless system.
5. 4G will define it as Wireless Mobile Broadband Access (WMBA) which is in processing in IEEE 802.16e. This indicates for the internet availability. To avoid call interference in case of data download from any website the execution is in development. An extraordinary step in 4G wireless technology is that it will propose downlink data rate as 128 Mbps and uplink data rate 56 Mbps. The condition for the internet connectivity is the availability of hotspot which is the limitation of the service.
6. In Parallel with Worldwide Interoperability for Microwave Access (WiMAX), LTE a wireless system for the broadband access is intended to integrate in 4G mobile phones. There is difference between WiMAX and LTE. LTE goes for the IP Address and follows the same TCP / IP idea inherited from computer networking architecture. It will provide greater security as well as high data transferability, low latency, capability to regulate the bandwidth. 4G or LTE is also compatible with CDMA.
7. LTE and IEEE 802.16m are the two major wireless standards going to be introduced by 3GPP. Earlier one is approved permission for the more process while the second one is under attention and it will become a fragment of fourth generation wireless system. IPv6 is permitted by Version as a 4G wireless standard on June 2009 [5].

#### **1.7.1 Disadvantages of 4G system**

- Expensive hardware and infrastructure
- Costly spectrum (most countries, frequency bands are is too expensive)
- High end mobile devices compatible with 4G technology required, which is costly
- Wide deployment and upgrade are time consuming [1]

## **1.8 Fifth Generation Wireless Technology (5G)**

Fifth generation or 5G is the next generation of wireless technology standards planned to deploy around 2020. 5G is to facilitate wireless networks by delivering enhanced bandwidth, high data transfer rates and lower latency to a billion number of electronic devices. This is one of the most promoted issues in the world of technology which is promising to facilitate the access to self-driving vehicles, virtual reality (VR), and the Internet of Things (IoT). Telecommunication enterprises or regulation bodies for example 3GPP, WiMAX or ITU-R have not finalized any particular specification or official document for 5G yet.

At present Cell phones are not only serving as a communication tool but also being used for many other purposes. Earlier wireless technologies are facilitating the simplicity of telephone and data sharing whereas fifth generation is bringing a new level and turning the life of human as a real mobile life.

### **1.8.1 Features of 5G [1]**

- ❑ 1-10Gbps connections to end points in the field.
- ❑ Latency of 1ms
- ❑ 1000x bandwidth per unit area.
- ❑ 10-100x number of connected devices.
- ❑ Availability 99.999 percent.
- ❑ 100 percent coverage.
- ❑ 90 percent saving in system energy usage. [1]

This section concludes by with hindsight at existing wireless systems and also briefing the upcoming generation of wireless communication technologies in the table below. In

the next years these new technologies have a long approach to travel and exciting and amazing features are destined to roll out to come [3].

Table 1TABLE 1.1 GENERATION OF COMMUNICATION

Generation	Speed	Technology	Time period	Features
1G	14.4 Kbps	AMPS, NMT, TACS	1970 – 1980	During 1G Wireless phones are used for voice only.
2G	9.6/ 14.4 Kbps	TDMA, CDMA	1990 to 2000	2G capabilities are achieved by allowing multiple users on a single channel via multiplexing. During 2G Cellular phones are used for data also along with voice.
2.5G	171.2 Kbps 20-40 Kbps	GPRS	2001-2004	Internet becomes widespread and data becomes more appropriate. Multimedia services and streaming starts to grow. Cell Phones started to support web browsing, though limited number of cell phones have that facility.
3G	3.1 Mbps, 500-700 Kbps	CDMA-200 UMTS, EDGE	2004-2005	Supports multimedia services together with streaming. Worldwide access and movability across different types of device are made possible such as Telephones, PDA's etc.
3.5G	14.4 Mbps, 1-3 Mbps	HSPA	2006 – 2010	Provides higher throughput and speeds to support higher data
4G	100-300 Mbps. 3-5 Mbps 100 Mbps (Wi-Fi)	WiMax, LTE, Wi-Fi	Now (Read more on Transitioning to 4G)	Speeds for 4G are further increased to keep up with data access demand used by various services. High definition streaming is now supported in 4G. New phones with HD capabilities surface. It gets pretty cool. In 4G, Portability is increased further. World-wide roaming is not a distant dream.
5G	1-10 Gbps	Massive MIMO, Beamforming, mmwave	Soon (probably 2020)	Currently there is no 5G technology deployed. When this becomes available it will provide very high speeds to the consumers. It would also provide efficient use of available bandwidth. [9]

## 1.9 Final Thoughts

Remote innovation has been consistently developing to fulfill expanding needs and higher particular prerequisites. Since the arrangement of original versatile organizations, media transmission industry confronting part of new difficulties regarding innovation, effective use of range and above all security to end clients. Future remote advances will give super quick, highlight rich and exceptionally secure portable organizations. [56-1]

## 1.10 Global 5G spectrum update

Around the world, these bands have been allocated or targeted

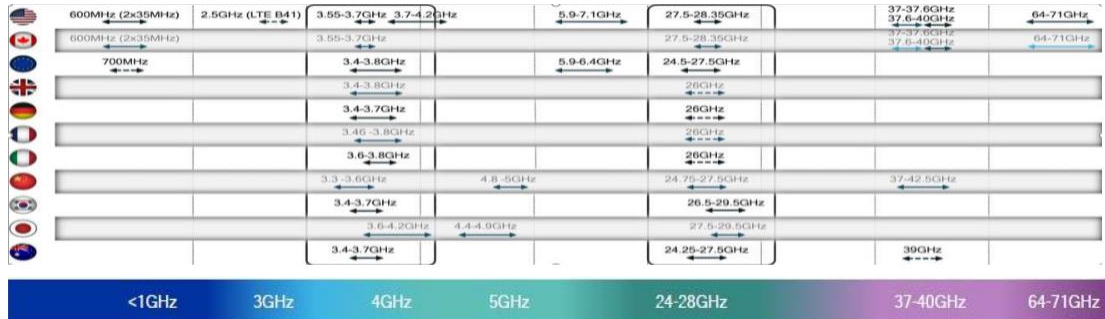

Figure 1.4 Global Spectrums

### 1.10.1 The FCC is driving key spectrum initiatives to enable 5G

Across low-band, mid-band, and high-band including mmWave

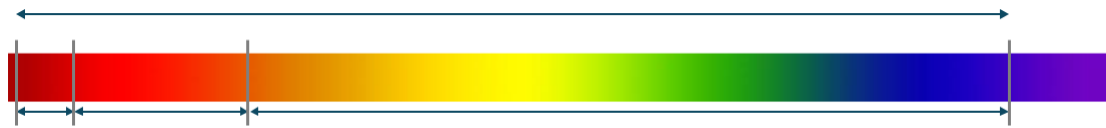

Figure 0-5Figure 1.5 5G spectrum [6-7]

### 1.10.2 Low-band

Broadcast Incentive Public sale

1. A part of the 600 MHz band was fruitfully auctioned that created \$19.8 Billion in profits after assignment phase.
2. 70 MHz of licensed spectrum consisting of 2 different channels and another 14 MHz for unlicensed use.
3. Spectrum availability timing aligns with 5G. [6-7]

### 1.10.3 Mid-band

Residents Broadband Radio Services

1. Initializing a 150 MHz spectrum in 3.5 GHz band with 3-layer sharing with incumbents, PAL1, GAA2.
2. FCC developed PAL directions in 2017 to create them appropriate for 5G.
3. To effort an LTE-based ecosystem CBRS Alliance was introduced officially.

4. Inquiry on 3.7-4.2 GHz and 5.9-7.1 GHz was notified by FCC. [6-7]

#### **1.10.4 High-band**

Spectrum Frontiers Ruling in 2016 & Second Ruling in 2017

1. Opening up around 11 GHz in several mmWave bands.
2. 70% of recently released bands is shared or unlicensed.
3. Consistently agreed. FCC requested for observation on another nominee spectrum branded for IMT-2020.
4. Considering adding 24.25-24.45, 24.75-25.25 GHz, and 42-42.5 GHz. [6-7]

#### **1.10.5 High-band: Spectrum Frontiers governing for 5G mmWave bands**

Key for more bandwidths are the shared and unlicensed spectrum.

Licensed Spectrum

1. 27.5 GHz – 28.35 GHz
2. 37.6 GHz – 38.6 GHz
3. 38.6 GHz - 40 GHz

Shared and unlicensed spectrum

1. 37 GHz– 37.6 GHz
2. 64 GHz- 71 GHz [6-7]

#### **1.10.6 5G Spectrum in Europe**

Concentration on mid-band (3.4 GHz–3.8 GHz) and 26 GHz band (24.25-27.5 GHz) To go faster 5G rollout in EU, regulatory activities are driven by EC RSC, CEPT, key European Member States.



Supervisory activities for 3.4-3.8 GHz and 26 GHz are run extremely with auctions predictable in 2017-2018.



5G approach for UK was published by the government in March 2017.

- ❑ Ofcom planned to auction 150 MHz channel in 3.4 GHz–3.6 GHz in 2017-2018 and 110MHz channel in 3.6 GHz – 3.8 GHz in 2018-2019.
- ❑ For timely 5G organization, Ofcom has introduced a work platform on 26 GHz band accessibility.
- ❑ Italian government is expected to auction 700 MHz, 3.6 GHz – 3.8 GHz and 26.5 GHz – 27.5 GHz in 2018.
- ❑ Ireland government successfully auctioned 350 MHz of frequency spectrum for 5G communication.
- ❑ Spain government tendered 3.6 GHz-3.8 GHz band permitting to market demands and operators needs in 2018.
- ❑ Spain focusing on 26 GHz band. At least 1.4 GHz bandwidth is available for release in 2018.

Other countries like Austria, Belgium, Switzerland are organizing to free spectrum in 2018-2019-time frame. [6-7]

## **1.11 Antenna Basics**

An antenna could be a dedicated electrical device that transforms radio-frequency (RF) fields into power or vice-versa. There are unit 2 basic types: the receiving antenna, that captures RF energy and delivers electrical energy to the instrumentality, and conjointly the sending antenna, that's fed with power from the instrumentality and produces radio-frequency field. In wireless applications, the foremost common sort of antenna is that the microstrip patch antenna, used for wireless communications. Microstrip patch antennas are unit sometimes wise entirely at microwave frequencies.

### **1.11.1 Frequency**

In normal sense frequency means how frequently occurs a particular event in a particular period. Basically, frequency refers to the number of occurrences of an event in a definite time. From the typical definition, “The number of recurrences of a signal over a defined time period (1 second), is known as frequency. Periodic signal repeats itself after every ‘T’

second called time period. Frequency of periodic signal is nothing but the inverse of time period (T). Figure 1.6 and 1.7 shows frequency diagram. In engineering terminology, frequency is used to identify the rate of oscillatory and vibratory occurrences, for example radio waves, audio signal (sound), mechanical vibrations, and light. The SI (International System) unit of frequency which is entitled by the German physicist Heinrich Hertz is hertz (Hz). One hertz denotes that an event or signal repeats once per second.

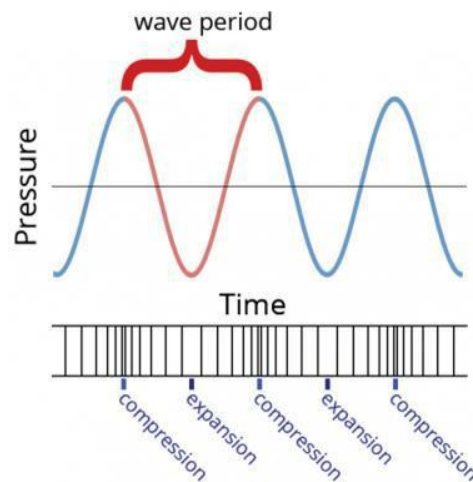

Figure 0-6Figure 1.6. Frequency diagram

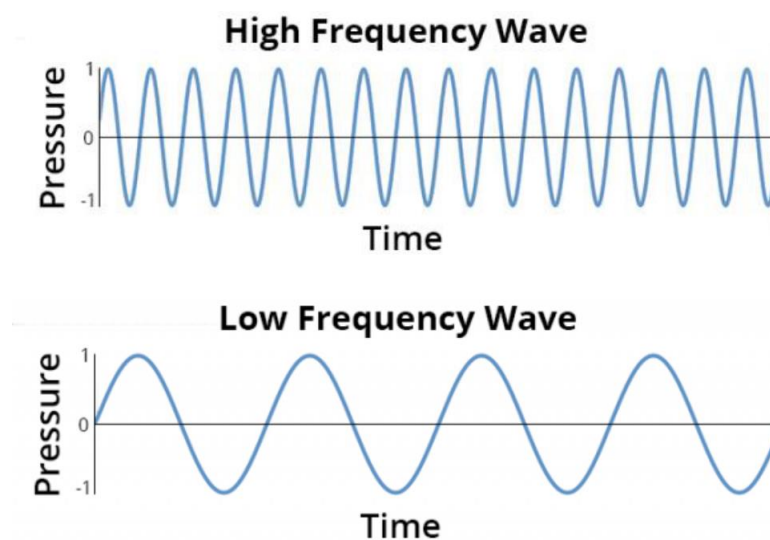

Figure 0-7Figure 1.7. High frequency and Low frequency diagram

### 1.11.2 Bandwidth

In communication systems, information measure is outlined because the capability of a wired or wireless communications system link to transmit the most quantity of knowledge from one purpose to a different over a electronic network or web association in a very given quantity of your time, generally in one second. just in case of antenna, information measure refers to the vary of frequency over that the antenna will properly radiate or receive energy. Regularly, information measure is one amongst the foremost desired decisive parameters wont to decide upon AN antenna. asanexample, several antenna sorts have terribly slim bandwidths and can't be used for broadband operation. Figure 1.8 shows information measure in diagram.

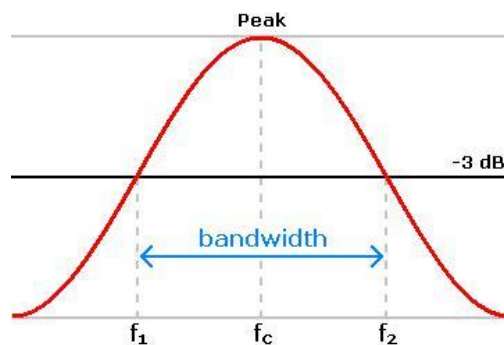

Figure 0-8Figure 1.8. Bandwidth diagram

### 1.11.3 Input Impedance

The input electrical resistance of associate antenna is that the magnitude relation of the voltage to the present at the antenna input terminals. it's a very important parameter of associate antenna, that expresses the resonance of the antenna. There ar 2 elements of the input electrical resistance – real and imagined. the facility that's radiated away or absorbed among the antenna is drawn by the  $R$  a part of the input electrical resistance. the facility that's hold on within the close to field of the antenna is drawn by the pure imaginary number of the input electrical resistance that is thought as mirrored power. A resonant antenna may be a one whose real input electrical resistance and 0 imagined electrical resistance. The input electrical resistance of associate antenna is decided by the length and size of that antenna.

Impedance is denoted by  $Z$  which has a real portion, including the antenna's radiation resistance  $R_{rad}$  and its ohmic losses  $R_{ohmic}$ , and a reactive portion  $X$  [7].

#### 1.11.4 Impedance Matching

The input resistivity of Associate in Nursing antenna is that the quantitative relation of the voltage to the current at the antenna input terminals. It's a vital parameter of Associate in Nursing antenna, that expresses the resonance of the antenna. There square measure 2 components of the input resistivity – real and unreal. The facility that's radiated away or absorbed inside the antenna is delineate by the important a part of the input resistivity. The facility that's keep within the close to field of the antenna is delineate by the pure imaginary number of the input resistivity that is understood as mirrored power. A resonant antenna could be a one whose real input resistivity and nil unreal resistivity. The input resistivity of Associate in Nursing antenna is decided by the length and size of that antenna.

Necessity of Matching:

A resonant device is one, which yields better output at certain narrow band of frequencies. Antennas are such resonant devices whose impedance if matched, delivers a better output.

1. The power from the source will be effectively delivered to the feedline, if the feedline impedance matches the source impedance.
2. The power from the feedline will be effectively delivered to the antenna, if the antenna impedance matches the feedline impedance.
3. For a receiver antenna, antenna's output impedance should match with the input impedance of the receiver amplifier circuit.
4. For a transmitter antenna, antenna's input impedance should match with transmitter amplifier's output impedance, along with the transmission line impedance [9].

#### 1.11.5 Directivity and Gain

The ability of an antenna to radiate energy in a particular direction when transmitting, or to receive energy better from a particular direction when receiving is called directivity.

And gain is generally described as the energy proportion generated by the antenna from a distant source on the beam axis of the antenna to the energy generated by a hypothetical isotropic lossless antenna, which is similarly susceptible to all directions of signals. There is a gain-directivity connection. This connection is recognized when comparing a light bulb to a spotlight by the phenomenon of enhanced directivity. A 100 watt spotlight in a specific direction will provide more light than a 100 watt light bulb and less light in other directions. The light bulb may be said to have less "directivity" than the spotlight. The spotlight is similar to a high-directivity antenna. Gain is directivity's practical value. Gaining mathematically equals multiplying directivity and efficiency. The gain-directivity relationship involves a fresh parameter ( $\pi$ ) known as the antenna efficiency [8]. Figure 1.9 shows Directivity and Gain.

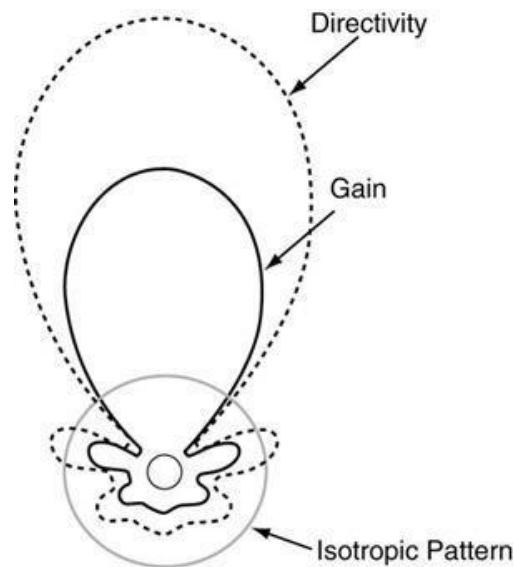

Figure 0-9 Figure 1.9: Directivity and Gain

### 1.11.6 Radiation Pattern

In the field of antenna design the term radiation pattern (or antenna pattern or far-field pattern) refers to the directional (angular) dependence of the strength of the radio waves from the antenna. Radiation pattern describes the relative strength of the radiated field in various directions from the antenna at a constant distance. The radiation pattern is a “reception pattern” as well, since it also describes the receiving properties of the antenna.

The radiation pattern is three-dimensional, but it is difficult to display the three-dimensional radiation pattern in a meaningful manner. Figure 1.10 shows radiation pattern.

It is also time-consuming to measure a three-dimensional radiation pattern. Often radiation patterns measured are a slice of the three-dimensional pattern, resulting in a two-dimensional radiation pattern which can be displayed easily on a screen or piece of paper. These pattern measurements are presented in either a rectangular or a polar format [7].

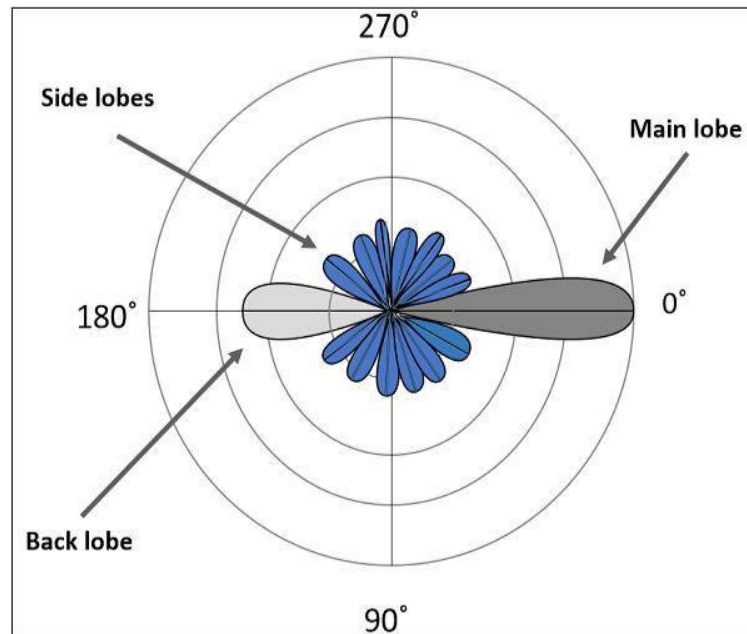

Figure 0-10Figure 1.10. Radiation pattern

### 1.11.7 Voltage Standing Wave Ratio (VSWR)

VSWR (Voltage undulation Ratio) may be a live of however expeditiously radio-frequency power is transmitted from an influence supply, through a line, into a load. In alternative words, the quantitative relation of most power to minimum power within the wave is measured and is termed the undulation quantitative relation (SWR). In term of voltage, the quantitative relation of the mirrored voltage over the incident voltage is termed VSWR. The VSWR is usually a true and positive variety for antenna. The smaller the VSWR is, the higher the antenna is matched to the line and also the additional power is delivered to the antenna. The minimum VSWR is one during this case, no power is mirrored from the antenna, that is good case [7]. Figure 1.11 shows VSWR in figure.

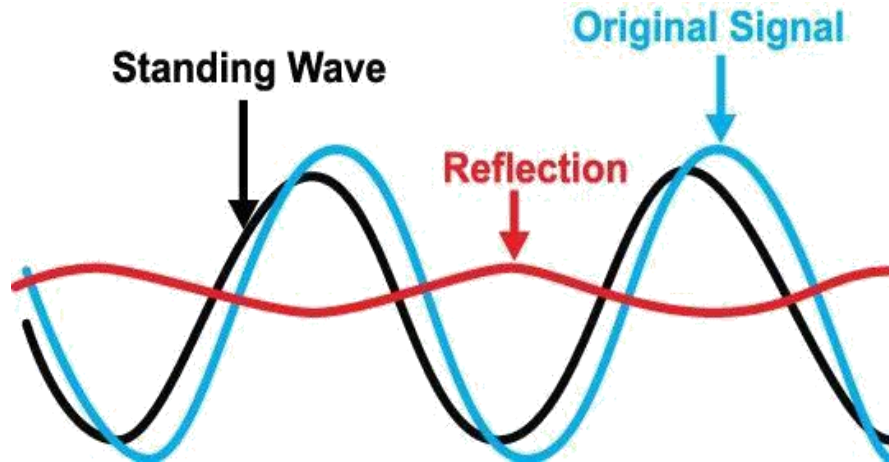

Figure 0-11Figure 1.11. VSWR

### 1.11.8 Return Loss (RL)

The return loss (RL) is another way for mismatch to be expressed. The algorithmic ratio measured in dB compares the energy the antenna reflects to the energy supplied from the transmission line into the antenna. The RL has a direct connection to the VSWR.

In practice, the most frequently cited antenna parameter is S11. In fact, S11 is nothing but the loss of return (RL). If S11= 0 dB, the antenna reflects all the forces and nothing radiates. If S11 = -10 dB, this means that the reflected energy is -7 dB if 3 dB of energy is supplied to the antenna. The acceptable upper 2 VSWR corresponds to a -9.5 dB or lower RL or S11. RL of -10 dB is considered acceptable in this thesis. [7].

### 1.11.9 Polarization

The polarization of an antenna is determined by the electric field of the wave emitted by the antenna. Specifically, the magnitude and phase of the electric field dictate the antenna's polarization. If the magnitudes and phases of the electric field components are equal, the antenna is linearly polarized. If the magnitudes are equal, but the phases differ by 90 degrees, the antenna is circularly polarized.

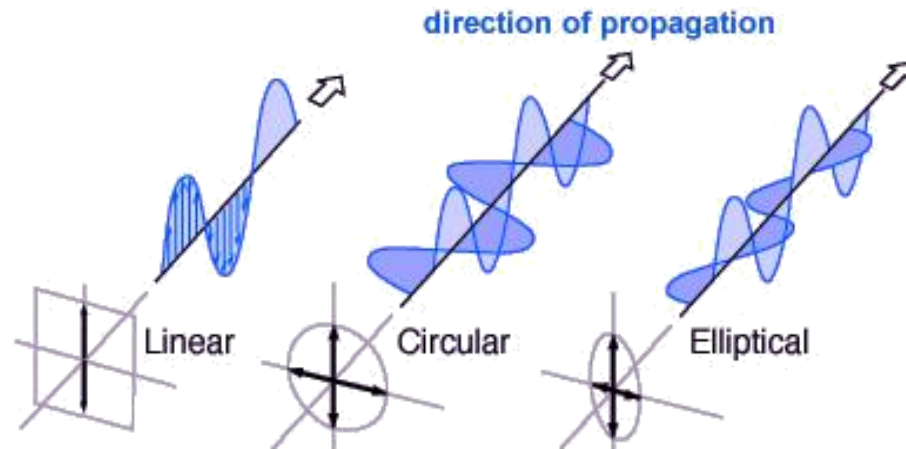

Figure 0-12 Figure 1.12 Polarization Linear, Circular, Elliptical [12-9]

## 1.12 Microstrip Antenna

A microstrip patch antenna consists of a radiating patch on one side of a dielectric substrate which has a ground plane on the other side as shown in Figure 3. The patch is generally made of conducting material such as copper or gold and can take any possible shape. The radiating patch and the feed lines are usually photo etched on the dielectric substrate.

In order to simplify analysis and performance prediction, the patch is generally square, rectangular, circular, triangular, and elliptical or some other common shape. For a rectangular patch, the length ( $L$ ) of the patch is usually  $0.3333\lambda_0 < L < 0.5\lambda_0$ , where  $\lambda_0$  is the free-space wavelength. The patch is selected to be very thin such that  $t \ll \lambda_0$  (where  $t$  is the patch thickness). The height  $h$  of the dielectric substrate is usually  $0.003\lambda_0 \leq h \leq 0.05\lambda_0$ . The dielectric constant of the substrate ( $\epsilon_r$ ) is typically in the range  $2.2 \leq \epsilon_r \leq 12$ .

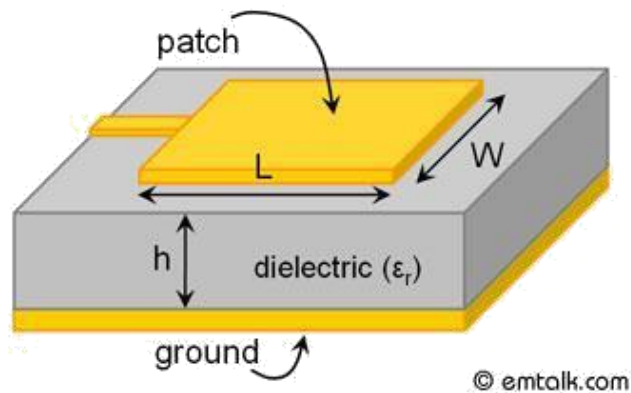

Figure 0-13 Figure 1.13 Structure of a Microstrip Patch Antenna [12-9]

### 1.12.1 Microstrip Line Feeding

In this type of feeding a microstrip transmission line is etched directly to the edge of patch which remains the total structure in same plane.

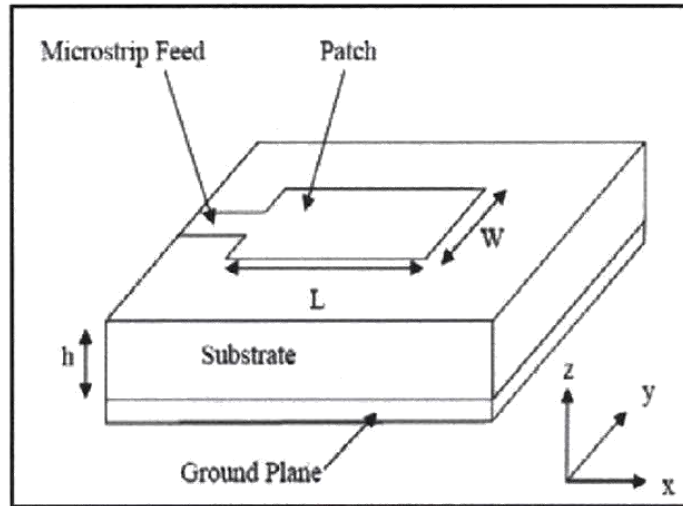

Figure 0-14 Figure 1.14 Microstrip Line Feeding [11-7]

### 1.12.2 Advantages and Disadvantages of Microstrip Antenna

Microstrip patch antennas are increasing in popularity for use in wireless applications due to their low-profile structure. Therefore, they are extremely compatible for embedded antennas in handheld wireless devices such as cellular phones, pagers etc. The telemetry and communication antennas on missiles need to be thin and conformal and are often microstrip patch antennas.

Some advantages of the microstrip antenna are given below:

1. Microstrip antennas are lightweight and low volume.
2. They can be fabricated at low cost, hence can be manufactured in large quantities.
3. They have Low profile planar configuration, which can be easily made conformal to host surface.
4. Supports both, linear as well as circular polarization

5. Microstrip antennas can be easily integrated with microwave integrated circuits (MICs).
6. They are Capable of dual and triple frequency operations.
7. They mechanically robust when mounted on rigid surfaces.

Some disadvantages of the Micro-strip antenna are given below:

1. Microstrip antenna has narrow bandwidth.
2. Their efficiency is low.
3. They are of low gain.
4. They suffer extraneous radiation from feeds and junctions.
5. Poor end fire radiator except tapered slot antennas
6. Their power handling capacity is low.

## **1.13 Design Tool**

### **1.13.1 CST Microwave Studio**

CST MICROWAVE STUDIO (CST MWS) is a high-quality means for the 3D electromagnetic simulation of high frequency structures. CST MWS enables the user fast and precise analysis of high frequency components for example antenna, filters, couplers, planar and multi-layer structures and SI and EMC effects. The software has both Time Domain solvers and Frequency Domain solvers. CST deals with further solver modules for particular applications. Filters for the import of specific CAD files and the extraction of SPICE parameters enhance design possibilities and save time. CST offers accurate, efficient computational solutions for electromagnetic design and analysis. Our 3D EM simulation software is user-friendly and enables you to choose the most appropriate method for the design and optimization of devices operating in a wide range of frequencies.

## **1.14 Motivation**

From the beginning of the emergence of wireless communication it has become very popular because of its cost efficiency, flexibility, mobility and many other features. So, rapid growth in the demand of mobile connection, data rate, and mobile data traffic has

been seen during the last three decades. Again, Internet of Things (IoT) has added a new extent to these demands. To meet this growing demand, telecommunication industry has been evolving different generations of standards in almost every decade. 5th generation (5G) is the consequence of them, which is to meet the demands of connectivity of more than 100 billion wireless devices, low latency of millisecond level, data rate of 10 Gbps, internet of things etc. deploying in the early 2020s [10]. One of the key challenges for the deployment of 5G is the path-loss in high frequency which motivated us to design an antenna that can cope with this challenge.

### **1.15 Essence**

The industry of telecommunication is evolving rapidly. There is coming a new generation in almost every 10 years. 5G is the preceding one, which is of utmost interest for the researchers. The enormous increases in wireless application, technologies are leaped from Fourth Generation (4G) to Fifth Generation (5G). 5G is the next wireless communication standards after 4G/IMT- Advanced standards. 5G is coming up with high capability than present 4G and it will allow a better density for wireless network users, which is aiding device to device ultra-reliability and large machine communication and also Internet of Things (IoT). As wireless communication is not possible without the employment of antenna, we need to design antennas having 5G compatibility.

For antenna design, microstrip patch antenna is the most well-liked antenna in nowadays wireless communication because of its unparalleled characteristics. This antenna type has smaller size and hence will provide small size end devices. The microstrip based antennas are easily etched on any PCB. The microstrip patches have various shapes e.g. rectangular, square, triangular etc. are easily etched. They have lower fabrication cost and hence they can be mass manufactured. They are capable of supporting multiple frequency bands (dual, triple). They support dual polarization types linear and circular both. They are light in weight.

The current 4G network is using sub-6-GHz bands for communication. But the available spectrum resources of these bands can't support the requirements of 5G [10]. So, we must have to move to the higher frequency bands ranging from 6-300 GHz. As a consequence, the following bands for 5G wireless communication including the 3.4-3.6 GHz, 5-6 GHz, 24.25-

27.5 GHz, 37-40.5 GHz and 66-76 GHz bands [9] and the federal communication commission has declared 27.5-28.35 GHz for 5G [10]. Several researches were performed on designing high gain microstrip patch antenna for 5G communication at 28 GHz [2] and 38 GHz. But some of those antennas do not cover the whole 28 GHz and 38 GHz bands as declared by FCC while others are not compatible with 5G mobile phone due to their large size. So, it is of utmost need to design an antenna that will cover the 28 GHz and 38 GHz band and compatible with 5G smartphone.

## Chapter 2

### Literature Review

#### 2.1 Overview of “Release 15 on 5G Standards” Update by 3GPP

3GPP (3<sup>rd</sup> Generation Partnership Project) members meet regularly to team up and form cellular communications standards. Currently 3GPP is defining standards for 5G. The International Telecommunication Union (ITU) has proposed some requirements for 5G that emphasis on accomplishing three key performance indicators (KPIs) [11]:

- ❑ >10 Gbps peak data rates for the enhanced mobile broadband (eMBB)
- ❑ >1M/km<sup>2</sup> connections for massive machine type communications (MMTC)
- ❑ <1ms latency for ultra-reliable low-latency communications (URLLC)

The table below provides an overview of specific technical requirements laid out as the 2020 minimum requirements.

Table 2 TABLE 2.1. TECHNICAL REQUIREMENTS OF 5G [8-11]

Metric	Requirement	Comments
Peak data rate	DL: 20 Gb/s UL: 10 Gb/s	Single eMBB mobile in ideal scenarios assuming all resources utilized
Peak spectral efficiency	DL: 30 b/s/Hz UL: 15 b/s/Hz	Single eMBB mobile in ideal scenarios assuming all resources utilized
User experienced data rate	DL: 100 Mb/s UL: 50 Mb/s	5% CDF of the eMBB user throughput
Area traffic capacity	Indoor hotspot DL: 10 Mb/s/m <sup>2</sup>	eMBB
User plane latency	eMBB: 4 ms URLLC: 1 ms	Single users for small IP packets for DL and UL (eMBB and URLLC)
Control plane latency	20 ms (encouraged to consider 10 ms)	Transition from idle to active (eMBB and URLLC)
Connection density	1 M devices per km <sup>2</sup>	For mMTC
Reliability	99.9999% success prob.	32 L2 bytes within 1 ms at cell edge
bandwidth	>100 MHz; up to 1 GHz in > 6GHz	Carrier aggregation allowed

It is a large responsibility to define an intact new standard for 5G. 3GPP has fragmented the 5G standardization into two different releases: Release 15, which relates to NR Phase 1, and Release 16, which relates to NR Phase 2. The common components between LTE and NR, such as both using orthogonal frequency division multiplexing (OFDM) are included in NR Phase 1.

However, there are also differences between LTE and NR as summarized in Table 2.

Table 3 TABLES 2.2. DIFFERENCES BETWEEN LTE AND NR [8-11]

	LTE	NR
Frequency of Operation	Up to 6 GHz	Up to 6 GHz, ~ 28 GHz, ~ 39 GHz, other mm Wave bands (Up to 52 GHz)
Carrier Bandwidth	Max: 20 MHz	Max: 100 MHz (at < 6 GHz) Max: 1 GHz (at > 6 GHz)
Carrier Aggregation	Up to 32	Up to 16
Analog Beamforming (dynamic)	Not Supported	Supported
Digital Beam forming	Up to 8 Layers	Up to 12 Layers
Channel Coding	Data: Turbo Coding Control: Convolutional Coding	Data: LDPC Coding Control: Polar Coding
Subcarrier Spacing	15 kHz	15 kHz, 30 kHz, 60 kHz, 120 kHz, 240 kHz
Self-Contained Sub frame	Not Supported	Can Be Implemented
Spectrum Occupancy	90% of Channel BW	Up to 98% of Channel BW

## 2.2 Paper Review

In this section the works by other researchers that are related to this thesis “Design and Simulation of a High gain Microstrip Patch Antenna for 5G Wireless Communication” will be reviewed, which is vital element to successful research to the fifth Generation (5G) mobile application with the existing antenna. Hence, for the design and simulation of an antenna with better performance and easy fabrication.

1. Research paper on, “Single Feed Compact Millimeter Wave Antenna for Future 5G Applications.”

In this research, a single-layer compact planar antenna has been proposed for upcoming 5G wireless transmission applications, printed on a low-cost dielectric substrate (RT-duroid 5880) and resonating at two frequencies- 28 GHz and 38 GHz. The finite element method (FEM) of Maxwell’s electromagnetic equations and the parametric study conducted showed the performances as peak gain 8.05dB, bandwidth 921MHz at 28

GHz band and peak gain 8.28dB, bandwidth 1.0451 GHz at 38 GHz band. In addition, bandwidths for both resonance frequencies improve significantly by the idea of merging unwanted narrow bandwidths. [12]

2. Research paper on, “Broadband Elliptical Slotted Patch Antenna for 5G Communications.”

In this paper, an elliptical slotted broadband patch antenna for future 5G communications is proposed. The size of the proposed antenna  $4.2 \times 4.2 \text{ mm}^2$  and the height is 0.127 mm. A rectangular ground with the elliptical slot and T shaped slotted patch is combined with a 50-ohm microstrip transmission line feeding technique is designed. The designed antenna covers the whole band from 22 GHz to 48 GHz which consists of three 5G frequency band, with appropriate gain and also obtained omnidirectional radiation pattern. The designed antenna array realized a high gain of nearby 18 dBi at 28 GHz and 21 dBi at 38 GHz. The proposed antenna in this paper can be a good candidate for upcoming 5G wireless communication. [13]

3. Research paper on, “Small Form Factor PIFA Antenna Design at 28 GHz for 5G Applications.”

This paper presents the look and analysis of lowest type issue flat Inverted-F Antenna at 28GHz for future 5G Mobile applications. gold-bearing strips are used for feeding and shorting of the antenna. The necessary options of this antenna squaremeasure its tiny step (0.25),gainof4.5dBi, 10 decibel impedance informati onmeasure of 1.55 ghz and radiation potency of ninety four. the total size of the PIFA antenna is 0.25. PIFA antennas performance greatly depends on ground plane size and its position on the bottom plane. It shows sensible graphical record once placed at the corner or edge. The PIFA antenna is meant on zero.8mm thick FR-4 substrate. Extra parasitic components are often additional to boost the information measure. [14]

4. Research paper on, “Design of 28 GHz Switched Beamforming Antenna System based on 4x4 Butler Matrix for 5G Applications.”

In this research, using microstrip technology a 4x4 Butler matrix beamforming antenna is proposed and designed for future 5G wireless communication. A substrate having low

dielectric constant is selected. The substrate and its shape are selected in a manner so that the antenna operates at 28 GHz band. The characteristics of the Butler matrix namely phase shifter, coupler and crossing are optimized for better performance. The return loss is around 42 dB and the peak gain is 6.79 dBi at 28 GHz. [16]

5. Research paper on, “A Novel 28 GHz Beam Steering Array for 5G Mobile Device with Metallic Casing Application.”

A novel beam steering antenna array operational at twenty eight GHz band has been with success investigated during this work. The advised antenna array shows noble performances in relations with come loss, antenna gain, radiation patterns, and beam steering facility. The planned antenna array has sixteen cavity-backed slot single component antennas that square measure utilized through the gold-bearing rear casing of the itinerant, during which 2 eight-element phased array antennas square measure fictitious on the left-side and right-side edges of the itinerant. every eight-element phased array antenna will manufacture beam steering at broadside and boresight gain of >15 dBi will be realised. The measured ten dB-bandwidth of the planned cavity-backed slot antenna component was nearly twenty seven.5–30 GHz. [17]

6. Research paper on, “A SAR Reduced Mm-Wave Beam-Steerable Array Antenna with Dual-Mode Operation for Fully Metal-Covered 5G Cellular Handsets.”

In this paper, a selected absorption rate (SAR) reduced twenty eight rate beam-steering array antenna with dual-mode operation for a completely metal-covered fifth-generation (5G) cellphone is projected. The projected antenna consists of 2 subarrays, every of that has eight turned slot antenna components, that square measure organized on the higher frame and on the a part of the rear cowl of the phone. The subarrays square measure designated per the modes by employing a switch. The projected array demonstrates sensible reflection coefficients within the waveband starting from twenty seven.2 to 28.2 rate and also the mutual couplings between antenna components square measure but –11.8 dB. The projected antenna has sensible beam-steering properties and a subfigure beam coverage. whereas the input power of every subarray is twenty four dBm, the calculated peak SAR values on the pinnacle phantom by the projected structure, for the beam scan angles of 0° and 40°, are 0.53 and 0.88 W/kg severally. [18]

7. Research paper on, “A 28-GHz U-slot Microstrip Patch Antenna for 5G Applications.”

In this study, a 28-GHz U-slot rectangular microstrip patch antenna for 5G Applications is planned. The U slot antenna thought has been utilized in patch antenna designed to scale back antenna size. The U-slot patch antenna structure consists of a patch, U-shaped slot, a ground plane and concentric feed lines. The planned antenna is intended and fictitious to satisfy the simplest doable result mistreatment simulation software package: Ansoft HFSS (High Frequency Structure Simulator) software version fifteen.0. Microstrip patch antennas square measure wide used as a result of their many blessings like light-weight weight, low volume, little size and low fabrication price. The planned antenna was measured and compared with the simulation results to prove the responsibility of the planning. The performance of the designed antenna was analyzed in term of gain, come loss, VSWR, and radiation diagram at frequency is twenty eight gigacycle. [19]

8. Research paper on, “Design a single Band Microstrip Patch Antenna at 60 GHz Millimeter Wave for 5G Application.”

In this paper, a single band microstrip patch antenna for 5G wireless application is presented. The antenna is simulated by electromagnetic simulation software, CST Microwave studio. The simulated antenna shows the return loss of 40.99 dB at 60 GHz. The proposed antenna has a gain of 5.48 dB with the radiation efficiency of -1.549 dB and total efficiency of -2.423 dB at 60 GHz. The design results show the center frequency at a 59.93 GHz with bandwidth of 4.028 GHz ranging from 57.981 GHz to 62.009 GHz. The structure of the proposed antenna is simple, low cost and small in size. Due to cutting the H and E slot, enhancement of the impedance bandwidth is obtained. [23]

9. Research paper on, “DESIGN and ANALYSIS of 28 GHz MICROSTRIP PATCH ANTENNA for DIFFERENT TYPE FR4 CLADDINGS”

In this study, rectangular patch microstrip antennas operating at 28 GHz frequency compatible with 5G mobile technology are designed with Computer Simulation Technology (CST) program for different patch materials and the performances of the designed antennas are compared. For each of the same sized antennas designed with the selected patch materials, it is found that they are suitable for the 28 GHz band and the

best return loss performance is obtained by using the tantalum conductor while the silver conductor has the best antenna efficiency. [24]

10. Research paper on, “Dual Band 5G Antenna design and SAR Calculations.”

This manuscript proposes the implementation of antenna proposed for 5G cellular communication and measuring the Specific Absorption Rate (SAR) in order to address whether the antennas being proposed for 5G communication could commercially be used according to criteria by Frequency Communication Commission (FCC). In this paper, a compact size dual bands square patch antenna has been modeled on two different software platforms High Frequency System Simulator (HFSS) & Computer Simulation Technology (CST) for 5G cellular communication. The proposed antenna has a compact structure of  $19 \times 19 \times 0.787 \text{ mm}^3$  including the ground plane which operates at 10.137 GHz and 28 GHz. The antenna has been designed on Rogers5880 substrate with a thickness of 0.787mm. The proposed design provides a gain of 5.61 dB at 10.176 GHz and 9.485 dB at 28.39 GHz using CST software and a gain of 7.324dB at 10.12 GHz and 9.573 dB at 29.6GHz by using HFSS software. The SAR is calculated at the operating frequency of 10.176 by averaging over a specific volume (typically a 1gram or 10gram area) and the maximum values as 0.8W/kg on 1 gram of tissues and 0.2W/kg on 10 grams of tissues have been calculated. Similarly, at the frequency of 28.39GHz, the maximum values of 1.4w/kg on 1 gram of tissues and 0.3w/kg on 10 grams of tissues are obtained.

11. Research paper on, “Compact and Low-Cost 3D-Printed Antennas Metalized using Spray-Coating Technology for 5G Mm-Wave Communication Systems.”

This paper presents proposals of high gain, efficient and compact 3D-printed antennas metalized using low-cost EMI/RFI spray-coating technology. The production cost of the antenna and the complexity of the fabrication procedure are reduced by using EMI/RFI conductive paint, whereas the antenna is providing suitable performance at 28 GHz band. Finally, the novel fabrication method is used in this research, offers the proposed antenna to be a probable candidate for low-cost future 5G mm-wave applications. [26]

12. Research paper on, “Directive Antennas for Future 5G Mobile Wireless Communications”

In this paper, a single directive antenna for the future 5G mobile wireless communications is proposed. Several gain enhancement techniques including Wilkinson array and series feed array are presented. Wilkinson array and series fed array obtained a

realized gain of 10.58 dB and 10.67 dB respectively. The proposed antenna element consists of elliptical patch printed on a low permittivity grounded substrate where it is fed by a  $50\Omega$  microstrip line on the backside of a second thin dielectric layer with a higher permittivity through an elliptical aperture etched in common the ground plane. [7]

13. Research paper on, “A SAR Reduced mm-Wave Beam-Steerable Array Antenna with Dual-Mode Operation for Fully Metal-Covered 5G Cellular Handsets”

In this letter, a specific absorption rate (SAR) reduced 28 GHz beam-steering array antenna with dual-mode operation for a fully metal-covered fifth-generation (5G) cellular handset is proposed. The proposed antenna consists of two subarrays, each of which has eight rotated slot antenna elements. The subarrays are selected according to the modes by using a switch. The proposed array demonstrates good reflection coefficients in the frequency band ranging from 27.2 to 28.2 GHz and the mutual couplings between antenna elements are less than -11.8 dB. The proposed antenna has good beam-steering properties and a hemispherical beam coverage for a millimeter-wave (mm-wave) 5G cellular handset. The calculated peak SAR values on the head phantom by the proposed structure, for the beam scan angles of  $0^\circ$  and  $40^\circ$ , are 0.53 and 0.88 W/kg, respectively, when the input power of each subarray is 24 dBm. [27]

14. Research paper on, “SAR Calculation and Temperature Response on Human Body Exposure for 28,30 and 60 GHz.”

The fast development of millimeter wave (mmWave) wireless communications and the associated concerns of potential negative impact on human health instigates the study on effects of mmWave frequency on the human body after exposure to electromagnetic field in terms of specific absorption rate (SAR) and temperature rise in computer simulation technology (CST). SAR distributions due to radiating source antenna were investigated using the finite difference time domain (FDTD) method in single and layered human tissues by examining the 1 g SAR (gram mass averaging) and point SAR (without mass averaging) at mmWave frequencies of 28, 40 and 60 GHz. The bioheat equation was used to find the temperature elevation in tissues. [28]

15. Research paper on, “Design of Dual-Band Metasurface Antenna.”

In this paper, a metasurface antenna for dual-band operation in 5G wireless systems is proposed. The metasurface consists of a single-layered square patch array which is excited by two microstrip feeding slots cut onto the ground. The metasurface patterns is optimized by using the characteristic mode analysis for the dual-band operation. The modes of metasurface resonate at 30 GHz, 38 GHz, and 41 GHz. To increase the bandwidth, the etched slots on the ground are resonant as well. The return loss is good over the frequency ranges of 23.75-28.8 GHz and 36.22-40.5 GHz with good impedance match. The simulated gain reaches 8.8-10.17 dBi and 9.46-12.6 dBi over the 28 GHz and 38 GHz bands, respectively. [29]

16. Research paper on, “28 GHz Compact Omnidirectional Circularly Polarized Antenna for Device-to-Device Communications in the Future 5G Systems.”

In this paper, an antenna design was proposed that attained omnidirectional circularly polarized radiation pattern in a simple, compact structure operating at 28 GHz band. It was demonstrated that the experimental results certified the design concepts and were in good agreement with their simulated results. A comparison of the prototype omnidirectional circularly polarized antenna to other antenna designs stated in the literature demonstrated. The proposed OCP antenna is the first one realized at 28 GHz that has a simple and compact structure, easy fabrication, and covers the proposed 5G 28 GHz band completely. So, the proposed OCP antenna is a potential nominee for upcoming 5G wireless systems, specifically for D2D communication applications. [30]

17. Research paper on, “Dual-Port 28 GHz Pattern Reconfigurable Quadruple Parasitic IFA Design for MIMO 5G Mobile Terminal.”

In this research, a pattern reconfigurable Quadruple Parasitic Inverted F Antenna (QPIFA) for Fifth Generation (5G) MIMO mobile terminal for operating in 28 GHz is presented. To facilitate the pattern reconfiguration a driven cross patch antenna surrounded by four parasitic inverted F antenna elements were used. To change the direction of the radiation beams the IFA parasitic elements and to connect the driven cross patch antenna metal shorting PIN diodes are used. At port 1 and port 2 four types of combination between the driven cross patch antenna and the IFA parasitic element.

18. Research paper on, “Electric field and specific absorption rate (SAR) analysis in multilayered skin tissue exposed to 5G mobile communication frequencies.”

This paper presents the electric field and specific absorption rate (SAR) distribution in the multilayered skin tissue exposed to 5G mobile frequencies, viz. 28 GHz, 38 GHz and 60 GHz. Presently, the safety limits for electromagnetic wave exposure above 6GHz are expressed in terms of power density by Federal Communications Commission (FCC). This study estimates the SAR values compliant to mentioned power densities. In the numerical scheme, Maxwell’s equation is employed to determine electric field, and SAR is estimated using electric field values. Results show that most of the energy associated with the 5G frequencies is absorbed in epidermis layer of skin tissue. Maximum electric field and SAR values are predicted in skin tissue exposed to 38 GHz radiation, while least electric field and SAR values are found at 60 GHz. 60 GHz can be considered the safest among all three frequencies for 5G mobile communications. [32]

19. Research paper on, “Modeling and Analysis of 5G Antenna Radiation Effect on Human Body By Calculating SAR Value Using Human Brain Model.”

There has been vast research going on in multiple domains of 5G communication and also the effects of 5G on health [1]. This manuscript proposes the implementation of antenna proposed for 5G cellular communication and measuring the Specific Absorption Rate (SAR) in order to address whether the antennas being proposed for 5G communication could commercially be used according to criteria by Frequency Communication Commission (FCC). In this paper, a compact size dual bands square patch antenna has been modeled on two different software platforms High Frequency System Simulator (HFSS) & Computer Simulation Technology (CST) for 5G cellular communication. The proposed antenna has a compact structure of  $19 \times 19 \times 0.787 \text{ mm}^3$  including the ground plane which operates at 10.137 GHz and 28 GHz. The antenna has been designed on Rogers5880 substrate with a thickness of 0.787mm. The proposed design provides a gain of 5.61 dB at 10.176 GHz and 9.485 dB at 28.39 GHz using CST software and a gain of 7.324dB at 10.12 GHz and 9.573 dB at 29.6GHz by using HFSS software. The SAR is calculated at the operating frequency of 10.176 by averaging over a specific volume (typically a 1gram or 10gram area) and the maximum values as 0.8W/kg on 1 gram of tissues and 0.2W/kg on 10 grams of tissues have been calculated. [33]

20. Research paper on, “Substrate Integrated Gap Waveguide Circularly Polarized Slot Antenna.”

In this paper a broadband aperture circularly polarized antenna based on substrate integrated gap waveguide (SIGW) for 5G millimeter wave applications is proposed. An inclined aperture is fixed on the metal layer of the SIGW and excitation is provided by microstrip transmission line of SIGW. Circularly polarized radiation mechanism is evaluated shortly. The simulated results demonstrate 10 dB-bandwidth from 24.8 to 31.7 GHz and 3-dB axial ratio bandwidth from 27.3 to 28.8 GHz. [34]

21. Research paper on, “Radiation Performance Analysis of 28 GHz Antennas Integrated in 5G Mobile Terminal Housing.”

In this research paper, several candidate 28 GHz antenna elements are integrated in a 5G mobile terminal. The radiation characteristics of the considered 5G antenna elements hurts from the terminal housing effects. At first the effects of guided waves, superstrates, surface currents, and the mobile user’s hand on 5G millimeter wave mobile phone antennas are identified and evaluated independently. Using the inverse source technique, the EQCs are obtained which provide a new perception of assisting 5G mobile phone antenna design in MHTE. Between measurement and simulation good agreement is obtained of EQCs. Through the coverage efficiency and the proposed effective beam-scanning efficiency, terminal housing effects on array and subarray performance are assessed. 5G mobile phone antenna design requires to take these effects into attention. The effective beam-scanning efficiency, in common with the coverage efficiency, can be advantageous performance indicators for 5G beam-scanning mobile phone terminals. [35]

25. Research paper on, “mmWave Novel Multiband Microstrip Patch Antenna Design for 5G Communication”

This paper presents a novel mmWave multiband patch antenna design for 5G communication. The 5G mmWave antenna resonates at band of 37 GHz and 54 GHz with maximum bandwidth of 5.5 GHz and 8.67 GHz respectively. The 5G mmWave multiband antenna is designed using microstrip technology with features light weight, low cost, low profile, high gain and efficiency. The 5G antenna is designed using simulation software CST MWS. It has small form factor of  $7.2 \times 5.0 \times 0.787$  mm<sup>3</sup>. The 5G

multiband antenna has sufficient realized gain of 5 dBi and 6 dBi respectively. It can be easily integrated in smart devices and used for 5G communication. [46]

26. Research paper on, “Empty Substrate Integrated Waveguide Slot Antenna Array for 5G Applications.”

Based on a unique structure of Empty Substrate Integrated Waveguide (ESIW) a slot array antenna is introduced in this research. The designed antenna delivers a low-loss and highly efficient performance operating at 28 GHz band. It has enhanced the viability of practical application in mobile phone in a way that is cost-effective and comparatively minor complexity in the planar design and modelling of antenna and integration in the mobile phone. The proposed antenna supports a 10 dB-bandwidth of almost 2.9 GHz specifically from 26.5 GHz to 29.4 GHz. The peak gain achieved at 28 GHz is 11.6 dBi. [36]

27. Research paper on, “Design of a Tri-Band Microstrip Patch Antenna for 5G Application.”

A triple band microstrip patch antenna for future 5G wireless communication is proposed in this paper. Rogers RT Duroid-5880 is used as the antenna substrate which have a low relative permittivity 2.2 and the thickness is 0.25 mm. The planned antenna is designed and simulated by two different commercial electromagnetic simulation software namely IE3D and HFSS and both results are compared. Simulation result depicts that the designed antenna provides reflection coefficient is better than 10 dB at three 5G bands. The peak gain is 6.65 dBi, 7.02 dBi and 5.05 dBi at 24.4 GHz, 28 GHz and 38 GHz respectively. [39]

28. Research paper on, “Design of 28/38 GHz Dual-Band Triangular-Shaped Slot Microstrip Antenna Array for 5G Applications.”

In this paper, dual band single element, two elements, four elements and six elements array antennas are proposed. The results show that the designed 5G antenna array has dual-band response at 28 GHz and 38 GHz bands. The simulated gain of single element antenna is 5.75 dBi and 7.23 dBi at 28 GHz and 38 GHz respectively. The highest gain is obtained for six elements array. The gain of 7.47 dBi and 12.1 dBi are obtained. Thus, the addition of radiating elements (array) of the antenna affects to the gain of antenna. [44]

## 2.3 Summary

Several researches were done on designing microstrip patch antenna for 5G communication at millimeter wave bands including 28 GHz, 38 GHz and others. From the current researches it is clear that among the millimeter wave bands 28 GHz and 38 GHz band is the most potential and important candidate for 5G wireless communication as many researches have been performed encompassing this band of frequency. Again, the most challenging job in deploying 5G is to design antenna having high gain to overcome severe path-loss, enough miniature to be able to integrate in mobile phone, efficient and easier to fabricate as well.

## 2.4 Objectives

- To design and simulate single element microstrip patch antenna for 28 GHz and 38 GHz.
- To Design Antennas for 28 GHz and 38 GHz on Four Specific dielectric elements and Detect One best antenna based on different results parameters.
- To Design Antennas for 28 GHz and 38 GHz on Different heights of detected dielectric elements and Detect one best antenna based on different result parameters.
- To Design Antennas for 28GHz and 38 GHz on Two Distinct Feeding technique of Detected Dielectric elements and Height Then Finally Detect one best antenna.
- To design and simulate 2×2 array antenna with the designed single element antenna for 28 GHz and 38 GHz of Detected Dielectric elements, Height and Feeding technique.
- To optimize the array antenna for better results.
- To compare with the existing 28 GHz array antennas.

## Chapter 3

### Methodology

#### 3.1 Methodology

Methodology is the organized, theoretical analysis of the methods applied to a field of study. It includes the theoretical analysis of the body of methods and doctrines related with a branch of knowledge. Typically, it encompasses concepts such as standard, theoretical model, phases and quantitative or qualitative techniques for a research [51]. Methodology can be said a set of practices or methods. This term may be used to refer to practices which are widely used across an industry or scientific discipline, the techniques used in a particular research study, or the techniques used to accomplish a particular project.

However, a methodology does not set out to afford solutions—it is thus, not the same as a method. Instead, a methodology deals with the theoretical reinforcement for understanding which method or set of methods can be realistic to a specific case.

#### 3.2 Research Design

The framework that has been fashioned to find solutions to the research questions is defined as research design. The design of a research work outlines the research resources such as research question, dependent and independent variables, experimental design, and where applicable, data collection methods and a statistical analysis plan.

Research Design for this research:

- Study on evolution towards 5G.
- Study on antenna requirements for 5G.
- Select 5G millimeter wave band.
- Study literature on microstrip antenna and existing 5G antennas.
- Study procedure of microstrip antenna design.
- Study antenna design procedure in CST Microwave Studio.

- Find out best substrate height
- Find out best feeding technique
- Implement the procedure.

### **3.3 Pilot Study**

A pilot study, pilot project, pilot test, or pilot experiment is a small-scale introductory study conducted in order to estimate the feasibility, time, cost, hostile events, and improve upon the study design prior to performance of a full-scale research work. It is conducted before the projected study. Pilot studies are usually executed as planned for the intended study. Though a pilot study cannot exclude all systematic errors or unexpected problems, but it lessens so many errors which waste time and effort during the original research study.

Importance of Pilot study:

- To test the research process and/or protocol.
- To categorize variables of concern and elect how to functionalize each one.
- To develop or examine the effectiveness of research instruments and protocols
- To evaluate statistical parameters for later investigations.

### **3.4 Software**

Computer Simulation Technology Microwave Studio (CST MWS) is a powerful tool for the 3D electromagnetic simulation of high frequency components. CST MWS allows the fast and precise analysis of high frequency (HF) devices such as filters, couplers, antennas, single and multi-layer structures and SI and EMC effects.

CST MWS offers unparalleled performance, making it first choice in technology leading research & development departments. Exceptionally user friendly, CST MWS quickly gives the user an insight into the EM behavior of high frequency designs [36].

### **3.5 Design procedure**

- Step 1: Firstly, a single element rectangular microstrip patch antenna (MPA) is designed to operate in 28 GHz band, based on the basic equations of designing MPA which is called equation-based antenna.
- Step 2: Save the structure and simulate the developed antenna.
- Step 3: Save the result if antenna meet criteria.
- Step 4: Optimize the developed Microstrip patch antenna for better performance.
- Step 5: cut the partial ground plane to get the wide band
- Step 6: Modelled the human brain by using brain tissue to calculate SAR value
- Step 7: Save the structure and simulate the developed antenna
- Step 8: Save the result if antenna meet criteria.
- Step 9: Calculate the SAR value for 1g of tissue.
- Step 13: Save the result if antenna meet criteria.
- Step 14: Compare the result with existing antennas.

#### **3.5.1 Antenna Substrates**

The first step of designing antenna is to select proper dielectric substrate of appropriate thickness ( $h$ ). Dielectrics are used to improve electrical and mechanical stability. They are used to reduce the size of the antenna and help to produce displacement current which in turns produces time varying Magnetic Field (by Ampere's Law). This time varying Magnetic Field can in turn produce time varying Electric Field (by Faraday's law) and a propagating electromagnetic field is created. In this way a substrate can enhance the radiation capability of the antenna. Some common dielectric substrates are listed below with their properties.

TABLE 3.1 LIST OF SUBSTARATES

Dielectric Name	Dielectric constant
FR4	4.4
RT Duroid-6002	2.94
RO4730	3
Rogers RO 3200	3.02
Rogers RT Duroid-5880	2.2
Rogers RT Duroid-5870	2.33
Foam	1
TLC-32	4.3

The dielectric constants of the substrates of the table above are comparatively high, which indicate high loss for designing high gain antenna. Firstly, we take randomly a substrate material namely as rogers RT-5880 which has dielectric constant close to 2.2 and this substrate material is mostly used for designing MPA design. Then the material of microstrip line and ground should be selected. In this case we have three choice- Copper, Silver or Gold. Silver has higher conductivity than the others. But copper is much harder and cheaper in cost than the other two. So copper is used normally.

### 3.5.2 Antenna Design by Equation

This antenna design methodology part is divided into several sections. First of all, designing the antenna radiating patch, this episode is basically containing with calculating the length and width of the patch. The sub-parameter that required to design this antenna radiating patch are the dielectric constant of the substrate (  $\epsilon_r$  ), height of the substrate (Hs) and the resonance frequency of the antenna [52]. Secondly, the feeding technique has been designed. There are basically two feeding technique used to design this antenna, the first one is inset fed and the second one is quarter wave transformer feeding technique. Finally, the quarter wave transformer feeding technique have selected as the feeding technique.

### 3.5.3 Radiating patch

1. Width design is important for good radiator design and to get desire resonance frequency of operation. So, width can calculate by using below equation (1).

$$w = \frac{c}{2f_r} \sqrt{\frac{2}{\epsilon_r + 1}} \dots \dots \dots (3.1)$$

Where,  $c$  = Velocity of Light ( $3 \times 10^8 ms^{-1}$ )

Effective dielectric constant is given by,

$$\epsilon_{eff} = \frac{\epsilon_r + 1}{2} + \frac{\epsilon_r - 1}{2} \left(1 + \frac{10h}{W}\right) \dots \dots \dots (3.2)$$

Where,

$\epsilon_{eff}$  = Effective dielectric constant, =  
 Dielectric constant of substrate,  $\epsilon_r$  =  
 Height of dielectric substrate,  $h$  =  
 Width of the patch.

For a given resonance frequency  $f_r$ , the effective length is given by,

$$L_{eff} = \frac{c}{2f_r \sqrt{\epsilon_{eff}}} \dots \dots \dots (3.3)$$

2. For determine the actual length L, two parameters such as effective dielectric constant and extension of length have to be calculated. Firstly, the effective dielectric constant is calculated using below equation.

$$L = L_{eff} - \nabla L \dots \dots \dots (3.4)$$

Where,

$$\nabla L = 0.412h \frac{(\epsilon_r + 0.3) \left(\frac{W}{h} + 0.264\right)}{(\epsilon_r - 0.258) \left(\frac{W}{h} + 0.8\right)} \dots \dots \dots (3.5)$$

**3.5.4 Feed-line**

1. Microstrip inset feed is the essentially feeding inset the radiating patch for proper impedance matching. Figure 3.2 shows inset feed line design. For calculating the inset feed location is calculating below equation (3.5.1).

$$x_0 = \frac{l}{x} \cos^{-1} \sqrt{\frac{Z_0}{Z_1}} \dots \dots \dots (3.5.1)$$

Where,

$Z_0=50 \Omega$  is the transmission line impedance.

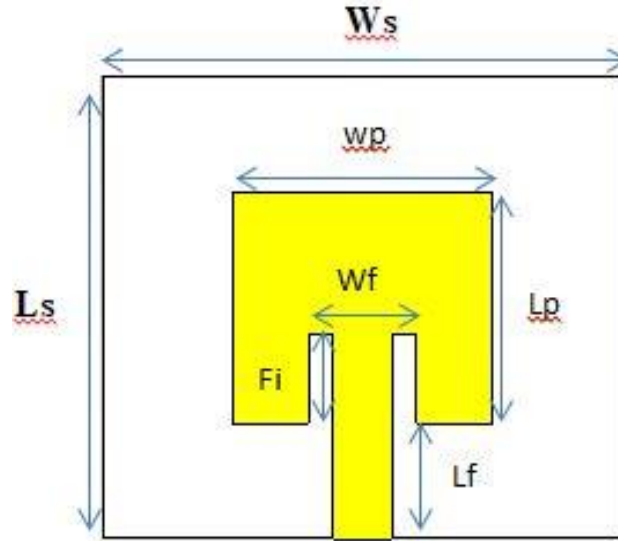

Fig. 3.1. Inset feed line design

In figure 01 we have seen the insertion feedline which is inserted in the proposed design antenna which has  $L_f$ = length of the feedline and  $W_f$ = width of the feedline and  $F_i$ = insertion feed of gap space. Then by using the above equations mentioned the designer of the proposed antenna for 28 GHz is illustrated in Figure 1 also and its back view and front view are shown in the following figure.

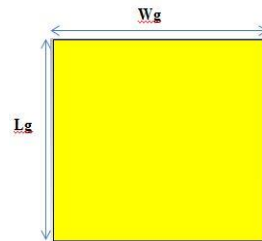

Fig. 3.2. Antenna back view

TABLE 3.1 DESIGNED ANTENNA PARAMETERS

Parameter	Value
Frequency ( $f_r$ )	28 GHz
Substrate height, $h$	1.5 mm
Dielectric Constant, $\epsilon_r$	1
Patch Length ( $L$ )	4.694
Patch Width ( $W$ )	7.43
Substrate Length= Ground Length	$2*L$
Substrate width= Ground width	$2*W$
Feedline Length, Width	2.456, 0.5
Gap Space ( $G_{pf}$ )	1.1

### 3.5.5 Partial Ground Plane

The partial ground plane concept can be introduced when it is needed to be the design wide band and sometimes needed to delete out the unwanted existing band to reduce losses in adjacent band and therefore here we introduced partial ground plane concept to do this so. The view of that partial ground plane is given as follows:

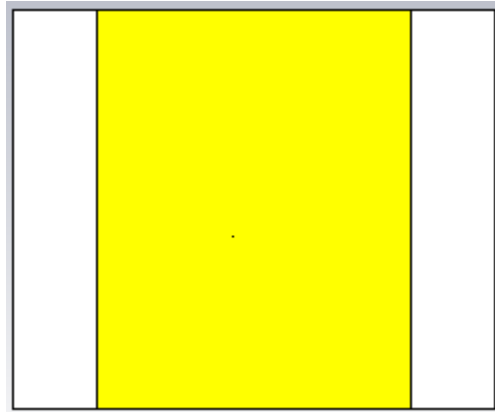

Fig. 3.3 Partial ground Plane

TABLE 3.3 PARTIAL GROUND PLANE PARAMETERS

Parameter	Value
Partial ground plane width, $w_{1g}$ (Xmin)	$-2 * w_p$
Partial ground plane width, $w_{1g}$ (Xmax)	$2 * w_p$
Partial ground plane length, $L_{1g}$ (Xmin)	$-2 * l_p$
Partial ground plane length, $L_{1g}$ (Xmax)	$2 * l_p$
Impedance	50 Ohm

### 3.5.6 SAR Concept and Human Brain Model

SAR is the power absorbed by body tissues, typically averaged either over the whole body or over a small part volume (typically 1 gm or 10 gm of tissue). International Commission on NonIonizing Radiation Protection (ICNIRP) and the Institute of Electrical and Electronics Engineers (IEEE) has been developed recommendations for confining the electromagnetic field exposure to keep the protection for the users from the dangerous of electromagnetic field (EMF) exposure. The limit was set as 2 W/kg regarding any 10 gm of human tissues according to IEEE C95.1:2005 by both mentioned organizations. On the other hand, SAR limit has been specified to 1.6 W/kg regarding 1 gm human tissues by the Federal Communication Commission (FCC) of

United States [1, 2]. SAR is defined as the derivative of increasing in the energy absorbed with respect to time by an increasing in mass contained in a volume part of a particular density, this definition according to IEEE [1, 3], the mathematical equation of SAR is indicated in eq. (1).

$$SAR = \frac{d}{dt} \left( \frac{dw}{dm} \right) = \frac{d}{dt} \left( \frac{dw}{\rho dm} \right)$$

Generally, the units of SAR is watts per kilogram (W/kg) or milliwatts per gram (mW/gm). SAR can be defined in terms of induced electrical field as shown in equation (2) [1,3].

$$SAR = \frac{\sigma E^2}{\rho}$$

Where: -  $E$  is the RMS value (root mean square) of electric field strength ( $V/m$ ).

$\sigma$  Represent the conductivity of biological tissue ( $/m$ )  $\rho$  Denote the density of biological tissue  $Kg/m^3$   $S$  Is the unit of electric (conductance, susceptance and admittance).

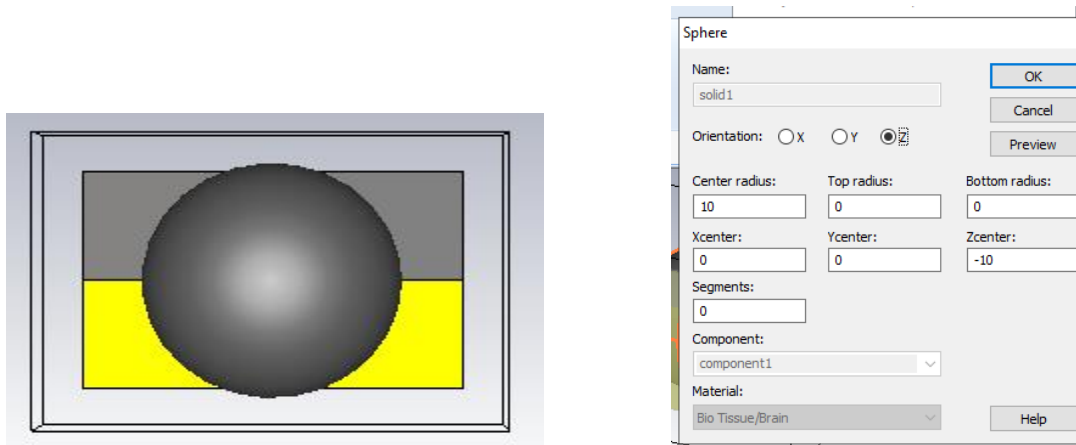

Fig. 3.4. Human Brain Model lay out its modelled properties

57

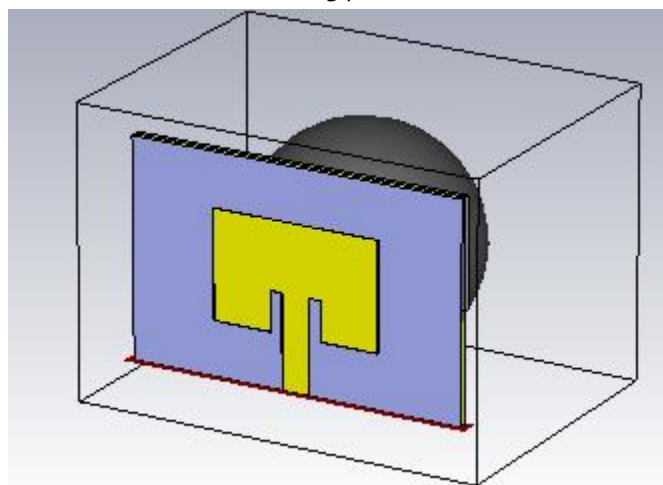

Fig. 3.8. Antenna Layout with human brain model

# CHAPTER 04

## Simulations and Results' Analysis

In this chapter, the results that are obtained after performing simulation of the designed antenna are presented and analyzed.

### 4.1 Simulation Results of Proposed Single Band Antenna

The result analysis and discussion that is shown in this section is mainly demonstrated on three antenna design parameters and this section is organized by three parts. This analysis was performed by monitoring seven result parameters. The final antenna design parameters are selected by observing antenna result parameters and the final antenna designed with those design parameters.

#### 4.1.1 Return Loss Graph

The return loss or parameter S11 is the most fundamental parameter to examine the efficiency of an antenna. Return loss provides data on an antenna's reflected energy. It is easy to determine the operating frequency and the antenna bandwidth from the return loss vs. frequency graph. The reduced the parameter value of S11 the stronger the resonance of the antenna. The parameter S11 vs. frequency graph is shown in figure 4.1 below. From this graph, the resonance frequency is 28 GHz and the return loss value is approximately 13dB which meets the standard required value for an antenna to be good its performance.

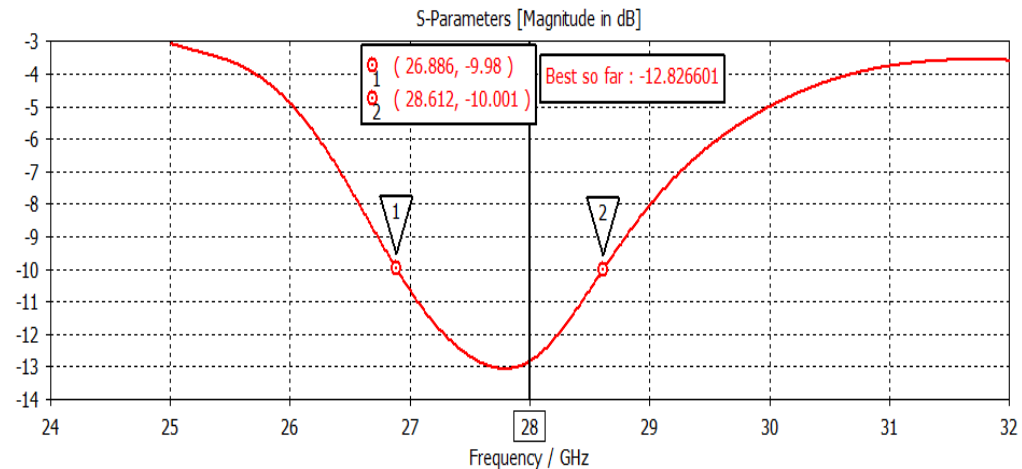

Figure 4.1 Return Loss Plot at 28 GHz

### 4.1.2 VSWR Plot

The VSWR is another parameter to determine the antenna's impedance match. It is actually a measure of impedance matching loads to a transmission line's characteristic impedance. Impedance discrepancies result in a standing wave along the transmission line and SWR is described as the proportion of the amplitude of the partial standing wave to the amplitude of a node along the line. VSWR's default value is 1 to 2. The graph below shows that the value of VSWR is within the normal limit of the working frequency range.

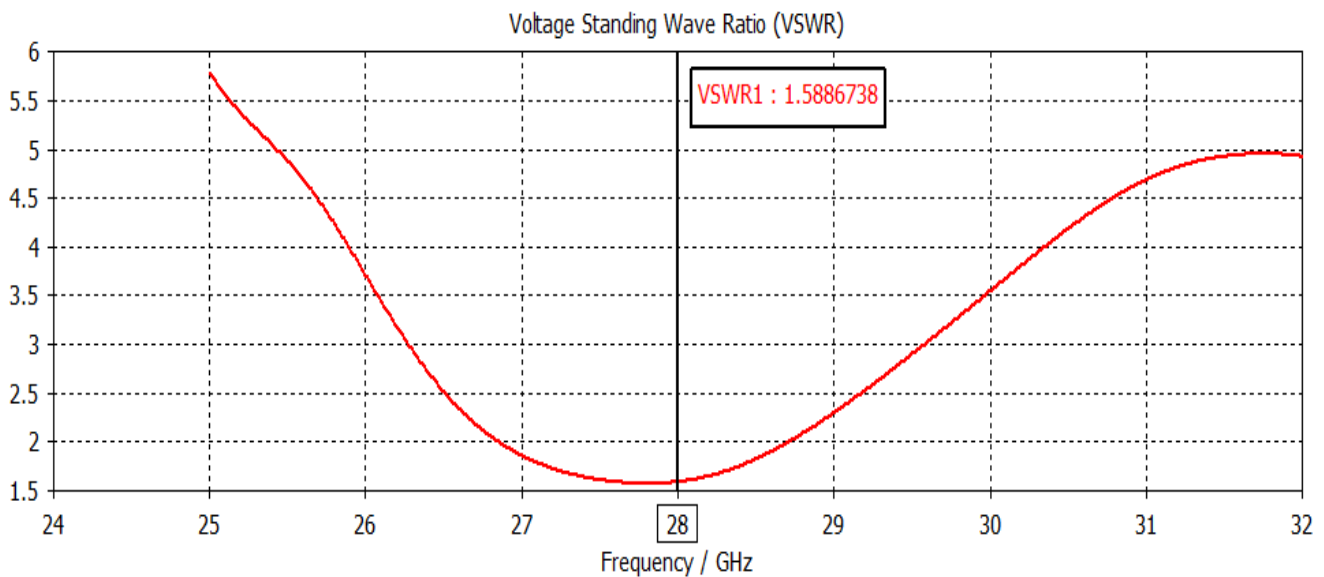

Figure 4.2 VSWR Plot at 28GHz

### 4.1.3 2D Radiation Pattern

The word radiation pattern in the field of antenna design relates to the directional reliance on the intensity of the antenna radio waves. 2D radiation pattern of single-element antenna showing a decent radiation pattern and a small beam width for the constructed antenna. The radiation pattern of microstrip patch antenna is half circular and we see that our radiation pattern is perfectly match the standard which is nearly half circular. The radiation pattern for the primary design is shown in the following figure for the resonant frequency band as seen that the gain is 11.5 which meets more higher accuracy gain as compared to standard value for 5G Communication.

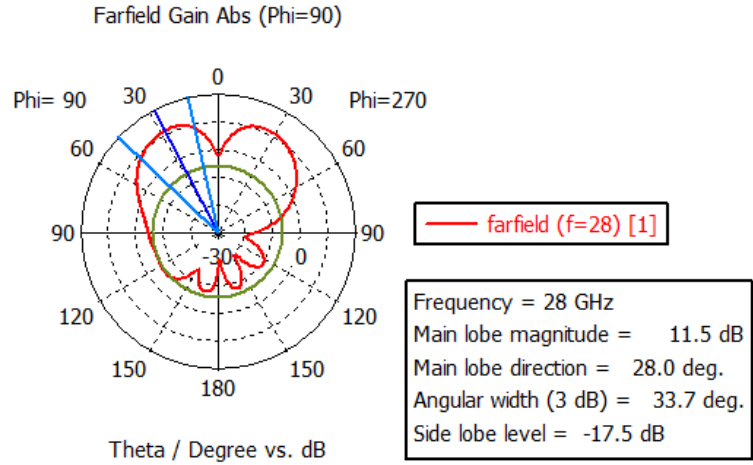

Figure 4.3 2D Radiation Pattern

#### 4.1.4 3D Radiation Pattern

A 3D radiation pattern is a 3-dimensional perspective of how energy in the surrounding room is radiated by an antenna. Usually this pattern is measured at a adequate distance from the farfield known antenna. Simply put, it is the energy that radiates in some direction with regard to an isotropic antenna (a theoretical antenna that radiates in all directions equally). Like the 2D radiation pattern, a healthy antenna should also keep its 3D radiation pattern throughout the operation frequency range. It is very simple to observe the energy supplied in a particular direction from the 3D radiation pattern. Primary design tri band microstrip patch antenna 3D radiation pattern is shown in the following figure.

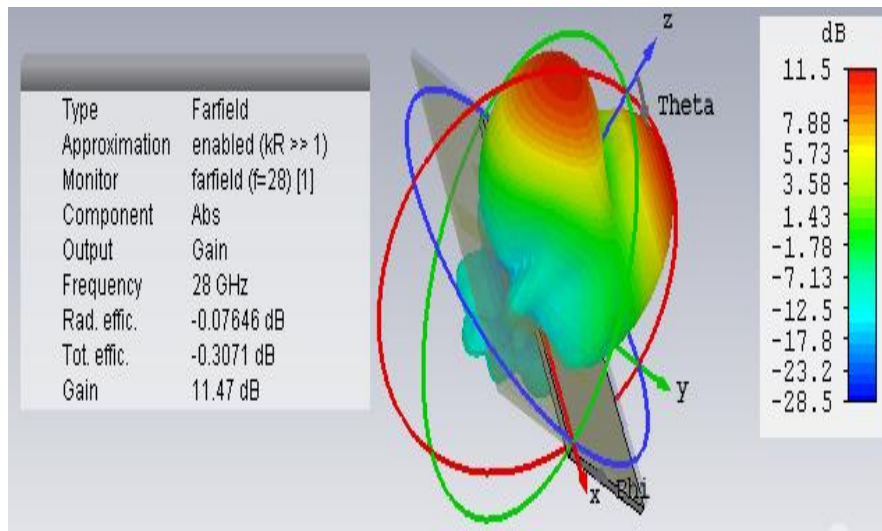

Figure 4.4 3D Radiation Pattern

### 4.1.5 Antenna Efficiency and Radiation Efficiency

Figure 4.7 Antenna Radiation Efficiencies for the primary designed microstrip tri band patch antenna. The effectiveness of the antenna is defined as the ratio of the effective aperture area to its actual physical area. It defines the proportion of radio frequency (RF) electricity actually capturing the physical aperture region. The tri band microstrip patch antenna met the normal antenna efficiency level of 93% for antenna and for radiation 98% efficiencies has been achieved from the simulation results at 28 resonant frequency.

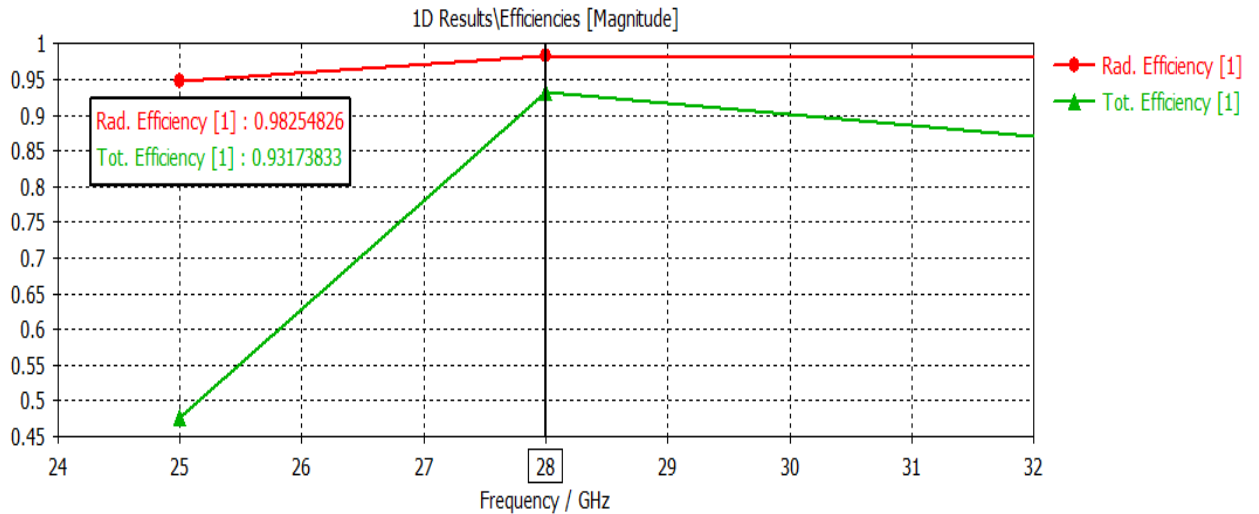

Figure 4.5 Efficiencies Plot at 28 GHz

### 4.1.6 Gain versus Frequency Plot

Gain versus frequency plot simply depicts the details gain of the proposed antenna for different frequencies in one plot and can be seen from the following diagram their respective gain for three different frequency bands.

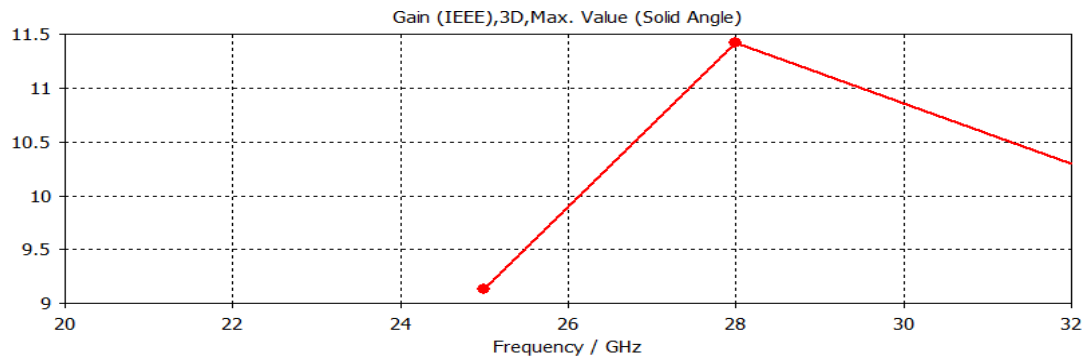

Figure 4.6 Gain Vs Frequency Plot

## 4.2 SAR Calculation Result

### 4.2.1 Radiation effect on Human Brain

In the rapid growth of wireless technology to higher frequencies making a big bad impact to health due to radiation effect. One of the most common impact falls due to radiation effect is on human brain tissue is the biggest dangerous thing to human health that can cause cancer and our designed antenna has rested with exact calculation to 1g of tissue that whether the designed antenna would fall impact to the users of radiation effect and need to be SAR value less than 1.7 W/kg to be safe. The following simulation result will show that the designed antenna is safe from the radiation effect of higher frequencies as its SAR calculated value is 0.378 W/kg which is too minimum and safe very efficiently.

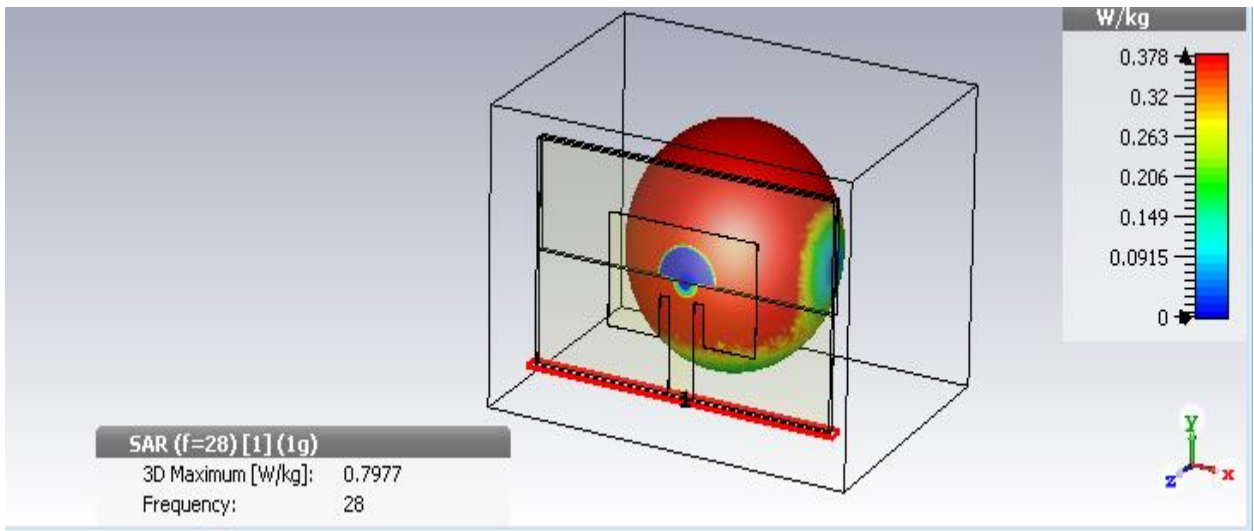

Figure 4.7 SAR Calculated Result at 28GHz

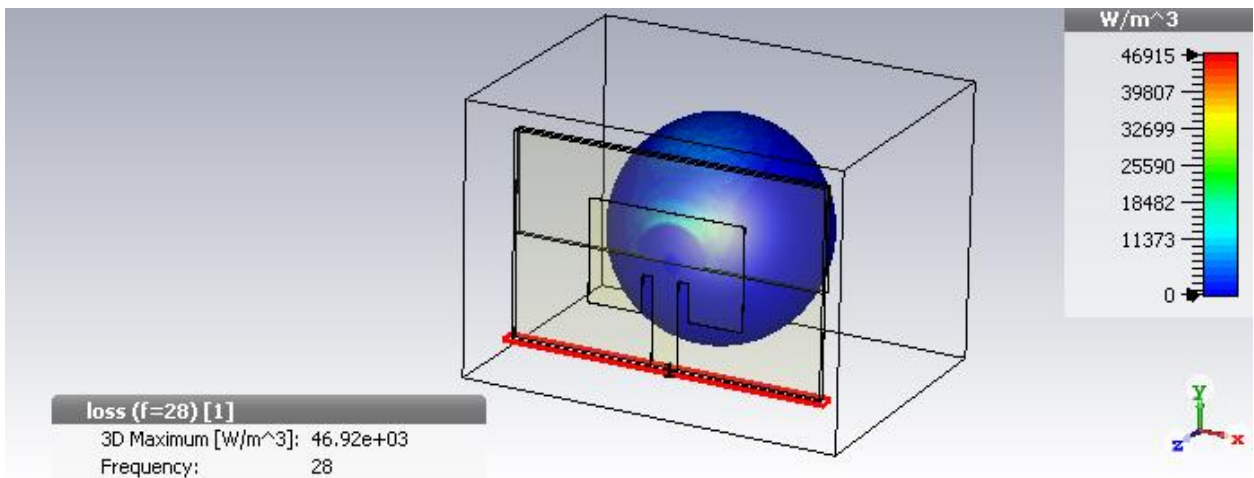

Figure 4.8 Power Loss at 28GHz

#### 4.1.4 Result of Final Single Element antenna.

TABLE 4.2 TOTAL SIMULATION RESULT OF SINGLE ELEMENT ANTENNA AT 28 GHZ

Parameters	Value	Standard [10]
Resonate Frequency	28 GHz	As per need
Bandwidth	1.84 GHz	As per need
Return loss (S11)	-13 dB	less than -10 dB
VSWR	1.002	2 - 1
Gain	11.5 dBi	6-9dBi
Directivity	12 dBi	5-8dBi
Antenna Efficiency	93%	70%
SAR Value	0.384 W/kg	< 2 W/kg

#### 4.2 Comparison with the existing 28GHz Single Band Antenna

In the following table, comparative views in-between proposed work with previous work. From those comparative views it can be seen that the proposed antenna designed by the three selected parameters satisfied the 5G requirements better than the previous work

Table 19TABLE 4.4 COMPARISON WITH THE EXISTING SINGLE ELEMENT ANTENNAS FOR 28 GHZ

Antenna ref.	year	Resonant Frequency (GHz)	Gain (dBi)	bandwidth	Efficiency
[46]	2019	28	7.02	2.12 GHz	90%
[47]	2019	28	6.9	1.73 GHz	86%
[48]	2020	28	7.87	1.1 GHz	83%
[49]	2020	38	6.9	1.67 GHz	90%
[50]	2018	28	9.82	1.29 GHz	99%
[51]	2017	60	5.48	4 GHz	-
[52]	2019	28	10.1	1.2 GHz	86.5%
[53]	2018	38	2	1.02 GHz	-
[59]	2019	30, 50	9.2, 10.6	2.09, 1.7 GHz	-
Proposed	2019	28	11.5	1.8 GHz	93%

## Chapter 5

### Conclusion

The main purpose of this work was to specify the design of the microstrip patch antenna according to the 5G requirements. The motivation of this work was that the antenna design at present time works with the specific requirement of 5G. Therefore, all 5G requirements are not fully implemented by such antenna. To make this work successful, three antenna design parameters are employed which are substrate elements, substrate heights and feeding techniques. Later, three parameters value fixed on these three antenna design parameters through antenna result through antenna result parameters analysis, which are Foam is as substrate element, substrate height is  $H_s=0.5\text{mm}$  and quarter wave transformer is as feeding technique respectively. After that, using those parameters single element antenna and antenna array designed at 28GHz those antennas satisfied the 5G requirements and shows better result than the previous work and calculated also SAR value and tested the antenna whether it is affective with radiation in 5G Technology.

#### 5.1 Achievements

In this thesis work, high gain single element microstrip patch antenna is designed and simulated successfully with  $50\Omega$  probe feed at both frequency of operation 28GHz. The proposed antenna operates at 28 GHz band with return loss below - 10dB. The VSWR of the simulated antenna is less than 1 through the whole frequency band which maintain the standard to exist between 1 and 2. The bandwidth of the antenna is around 1.8 GHz which completely covers the whole band of 28 GHz as declared by Federal Communications Commission (FCC) [54]. Single element Antennas gain is 11.5 dBi at 28GHz and which is better than the existing antennas found in literature review in terms of size. Also, tested SAR Value for 1g of tissue which is 0.348 W/kg and it less than as standard 2W/kg which is good and not risk in higher frequency communication and some of those are bulky in size to be incorporated in mobile phones. So, the proposed antenna array is a strong candidate to be used in future 5G mobile phones.

## **5.2 Limitations**

The proposed antenna is not facilitated with beam steering capability which will make this antenna more practical to be used in the mobile phones.

## **5.3 Future Work Field**

Beam steering facility can be incorporated to enhance the coverage angle of the antenna. Also, the designed and simulated antenna should be fabricated in practice to see the real environment performance and to compare the result of simulation with measured.

## References

- [1] <https://www.rfpage.com/evolution-of-wireless-technologies-1g-to-5g-in-mobile-communication>
- [2] P. Bevelacqua, "Antenna Basics", *Antenna-theory.com*, 2018. [Online]. Available: <http://www.antenna-theory.com/basics/main.php>. [Accessed: 06- Dec- 2018].
- [3] Mehta, Haard Patel, Darpit Joshi, Bhaumik Modi, and Hardik, "0G to 5G Mobile Technology: A Survey", *Journal of Basic and Applied Engineering Research*, Vol. 1, no. 6, pp. 56-60, October, 2014.
- [4] <https://support.chinavasion.com/index.php?/Knowledgebase/Article/View/284/42/1g-2g-3g-4g---the-evolution-of-wireless-generations>
- [5] "The 3D polar radiation patterns of dipole antenna with lengths, [Online], Available: [http://www.cisco.com/c/en/us/products/colateral/wireless/aironetwork-antennas/accessories/prod\\_white\\_paper](http://www.cisco.com/c/en/us/products/colateral/wireless/aironetwork-antennas/accessories/prod_white_paper), [Accessed:18 December 2017]
- [6] "overview of release 15" [online]: <https://spectrum.ieee.org/telecom/wireless/3gpp-release-15-overview> [accessed on 15 December 2018]
- [7] M. M. M. Ali and A. Sebak, "Directive antennas for future 5G mobile wireless communications," *2017 32th General Assembly and Scientific Symposium of the International Union of Radio Science (URSI GASS)*, Montreal, QC, 2017, pp. 1-4.
- [8] H. Jaafar, M. T. Ali, S. Subahri, A. L. Yusof and M. K. M. Salleh, "Improving gain performance by using air substrate at 5.8GHz," *2012 International Conference on Computer and Communication Engineering (ICCCE)*, Kuala Lumpur, 2012, pp. 95-98.
- [9] W. Hong; K. Baek; Y. Lee; Y. Kim; S. Ko, "Study and prototyping of practically large-scale mmWave antenna systems for 5G cellular devices," in *IEEE Communication Magazine*, 2014.
- [10] W. Hong *et al.*, "Multibeam Antenna Technologies for 5G Wireless Communications," in *IEEE Transactions on Antennas and Propagation*, vol. 65, no. 12, pp. 6231-6249, Dec. 2017.

- [11] M. Marcus, "WRC-19 Issues: Agenda Item 1.15 and the Use of 275–450 GHz", *IEEE Wireless Comm.*, Dec. 2016, p. 2–3.
- [12] A. Elfatimi, S. Bri and A. Saadi, "Single feed compact millimeter wave antenna for future 5G applications," *2018 International Conference on Intelligent Systems and Computer Vision (ISCV)*, Fez, 2018, pp. 1-4.
- [13] S. Das, M. Samsuzzaman, M. N. Rahman, M. T. Islam and M. T. Islam, "Broadband Elliptical Slotted Patch Antenna for 5G Communications," *2018 International Conference on Computer, Communication, Chemical, Material and Electronic Engineering (IC4ME2)*, Rajshahi, 2018, pp. 1-4
- [14] W. Ahmad, A. Ali and W. T. Khan, "Small form factor PIFA antenna design at 28 GHz for 5G applications," *2016 IEEE International Symposium on Antennas and Propagation (APSURSI)*, Fajardo, 2016, pp. 1747-1748.
- [15] D. Imran, M. M. Farooqi, M. I. Khattak, Z. Ullah, M. I. Khan, M. A. Khattak and H. Dar, "Millimeter Wave MicroStrip Patch Antenna for 5G Mobile Communication in 2018.
- [16] Siwar Louati, Larbi Talbi and Mohamed Ould Elhassen, "Design of 28 GHz Switched Beamforming Antenna System based on 4x4 Butler Matrix for 5G Applications," *2018 Fifth International Conference on Internet of Things: Systems, Management and Security (IoTSMMS)* pp. 19-20.
- [17] B. Yu, K. Yang, C. Sim and G. Yang, "A Novel 28 GHz Beam Steering Array for 5G Mobile Device with Metallic Casing Application," in *IEEE Transactions on Antennas and Propagation*, vol. 66, no. 1, pp. 462-466, Jan. 2018.
- [18] J. Bang and J. Choi, "A SAR Reduced mm-Wave Beam-Steerable Array Antenna With Dual-Mode Operation for Fully Metal-Covered 5G Cellular Handsets," in *IEEE Antennas and Wireless Propagation Letters*, vol. 17, no. 6, pp. 1118-1122, June 2018.
- [19] M. A. Saada, T. Skaik and R. Alhalabi, "Design of Efficient Microstrip Linear Antenna Array for 5G Communications Systems," *2017 International Conference on Promising Electronic Technologies (ICPET)*, Deir El-Balah, 2017, pp. 43-47.

- [20] N. Ojaroudiparchin, M. Shen and G. F. Pedersen, "A 28 GHz FR-4 compatible phased array antenna for 5G mobile phone applications," *2015 International Symposium on Antennas and Propagation (ISAP)*, Hobart, TAS, 2015, pp. 1-4.
- [21] S. X. Ta, H. Choo and I. Park, "Broadband Printed-Dipole Antenna and Its Arrays for 5G Applications," in *IEEE Antennas and Wireless Propagation Letters*, vol. 16, pp. 2183-2186, 2017.
- [22] M. E. Shorbagy, R. M. Shubair, M. I. AlHajri and N. K. Mallat, "On the design of millimetre-wave antennas for 5G," *2016 16th Mediterranean Microwave Symposium (MMS)*, Abu Dhabi, 2016, pp. 1-4
- [23] J. Saini and S. K. Agarwal, "Design a single band microstrip patch antenna at 60 GHz millimeter wave for 5G application," *2017 International Conference on Computer, Communications and Electronics (Comptelix)*, Jaipur, 2017, pp. 227-230.
- [24] W. A. W. Muhamad, R. Ngah, M. F. Jamlos, P. J. Soh and H. Lago, "Gain enhancement of microstrip grid array antenna for 5G applications," *2016 URSI Asia-Pacific Radio Science Conference (URSI AP-RASC)*, Seoul, 2016, pp. 1827-1829.
- [25] E. A. Abbas, A. T. Mobashsher and A. Abbosh, "Polarization reconfigurable antenna for 5G cellular networks operating at millimeter waves," *2017 IEEE Asia Pacific Microwave Conference (APMC)*, Kuala Lumpur, 2017, pp. 772-774.
- [26] S. Alkaraki *et al.*, "Compact and Low-Cost 3-D Printed Antennas Metalized Using Spray-Coating Technology for 5G mm-Wave Communication Systems," in *IEEE Antennas and Wireless Propagation Letters*, vol. 17, no. 11, pp. 2051-2055, Nov. 2018
- [27] J. Bang and J. Choi, "A SAR Reduced mm-Wave Beam-Steerable Array Antenna With Dual-Mode Operation for Fully Metal-Covered 5G Cellular Handsets," in *IEEE Antennas and Wireless Propagation Letters*, vol. 17, no. 6, pp. 1118-1122, June 2018, doi: 10.1109/LAWP.2018.2836196.
- [28] T. Hamed and M. Maqsood, "SAR Calculation & Temperature Response of Human Body Exposure to Electromagnetic Radiations at 28, 40 and 60 GHz mmWave Frequencies," *Progress In Electromagnetics Research M*, Vol. 73, 47-59, 2018.

- [29] T. Li and Z. N. Chen, "Design of dual-band metasurface antenna," *2018 International Workshop on Antenna Technology (iWAT)*, Nanjing, 2018, pp. 1-3.
- [30] W. Lin, R. W. Ziolkowski and T. C. Baum, "28 GHz Compact Omnidirectional Circularly Polarized Antenna for Device-to-Device Communications in the Future 5G Systems," in *IEEE Transactions on Antennas and Propagation*, vol. 65, no. 12, pp. 6904-6914, Dec. 2017.
- [31] S. Padmanathan, A. A. Al-Hadi, P. J. Soh, M. F. Jamlos and F. C. Seman, "Dual-port 28 GHz pattern reconfigurable quadruple parasitic IFA design for MIMO 5G mobile terminal," *2017 IEEE Asia Pacific Microwave Conference (APMC)*, Kuala Lumpur, 2017, pp. 791-794.
- [32] M. R. Laghari, I. H. Sadhayo, K. A. Memon, and K. Yaseen, "Modeling and Analysis of 5G Antenna Radiation Effect on Human Head by Calculating Specific Absorption Rate (SAR) using Adult Brain Model," *jictra*, pp13-10, dec, 2020.
- [33] M. S. Sharawi and M. Ikram, "Slot-based connected antenna arrays for 5G mobile terminals," *2018 International Workshop on Antenna Technology (iWAT)*, Nanjing, 2018, pp. 1-3.
- [34] D. Shen, C. Ma and X. Zhang, "Substrate Integrated Gap Waveguide Circularly Polarized Slot Antenna," *2018 IEEE Asia-Pacific Conference on Antennas and Propagation (APCAP)*, Auckland, 2018, pp. 460-461
- [35] B. Xu *et al.*, "Radiation Performance Analysis of 28 GHz Antennas Integrated in 5G Mobile Terminal Housing," in *IEEE Access*, vol. 6, pp. 48088-48101, 2018.
- [36] Z. U. Khan, Q. H. Abbasi, A. Belenguer, T. H. Loh and A. Alomainy, "Empty Substrate Integrated Waveguide Slot Antenna Array for 5G Applications," *2018 IEEE MTT-S International Microwave Workshop Series on 5G Hardware and System Technologies (IMWS-5G)*, Dublin, 2018, pp. 1-3.
- [37] S. Zhang, I. Syrytsin and G. F. Pedersen, "Compact Beam-Steerable Antenna Array with Two Passive Parasitic Elements for 5G Mobile Terminals at 28 GHz," in *IEEE Transactions on Antennas and Propagation*, vol. 66, no. 10, pp. 5193-5203, Oct. 2018.

- [38] M. Ikram, Y. Wang, M. S. Sharawi and A. Abbosh, "A novel connected PIFA array with MIMO configuration for 5G mobile applications," *2018 Australian Microwave Symposium (AMS)*, Brisbane, QLD, 2018, pp. 19-20.
- [39] Kamal, Md & Islam, Md & Uddin, Md & Imran, A.. (2018). Design of a Tri-Band Microstrip Patch Antenna for 5G Application. 1-3.  
10.1109/IC4ME2.2018.8465627.
- [40] S. Subramanian, S. K. Selvaperumal, V. Thangasamy and C. Nataraj, "Modified Triple Band Microstrip Patch antenna for Higher 5G bands," *2018 Fourth International Conference on Advances in Electrical, Electronics, Information, Communication and Bio-Informatics (AEEICB)*, Chennai, 2018, pp. 1-5.
- [41] D. N. Arizaca-Cusicuna, J. Luis Arizaca-Cusicuna and M. Clemente-Arenas, "High Gain 4x4 Rectangular Patch Antenna Array at 28GHz for Future 5G Applications," *2018 IEEE XXV International Conference on Electronics, Electrical Engineering and Computing (INTERCON)*, Lima, 2018, pp. 1-4
- [42] Zhang S, Chen X, Syrytsin I, and Pedersen G.F, "A Planar Switchable 3-D-Coverage Phased Array Antenna and Its User Effects for 28-GHz Mobile Terminal Applications," *IEEE Trans. Antennas Propagation*, 2017, 65, 6413–6421.
- [43] Syrytsin I, Zhang S, Pedersen G.F, Ieee S.M, and Morris A, "Compact Quad-Mode Planar Phased Array with Wideband for 5G Mobile Terminals," *IEEE Trans. of Antennas Propagation*, 2018, 77, 345-350.
- [44] Design of 28/38 GHz Dual-Band Triangular-Shaped Slot Microstrip Antenna Array for 5G Applications
- [45] N. Ashraf, O. Haraz, M. A. Ashraf, and S. Alshebeili, "28/38-ghz dual-band millimeter wave siw array antenna with ebg structures for 5g applications," in *Information and Communication Technology Research (ICTRC)*, 2015 International Conference on. IEEE, 2015, pp. 5–8.
- [46] Zeeshan Lodro<sup>1</sup>, Naila Shah<sup>1</sup>, Erum Mahar<sup>1</sup>, Syed Bilal Tirmizi<sup>1</sup>, Mir Lodro<sup>1</sup>, " mmWave Novel Multiband Microstrip Patch Antenna Design for 5G Communication" In *iCoMET 2019*.
- [47] D. Imran, M. M. Farooqi, M. I. Khattak, Z. Ullah, M. I. Khan, M. A. Khattak and H. Dar, "Millimeter Wave MicroStrip Patch Antenna for 5G Mobile Communication in 2018.

- [48] U. Rafique, H. Khalil and Saif-Ur-Rehman, "Dual-band microstrip patch antenna array for 5G mobile communications," *2017 Progress in Electromagnetics Research Symposium - Fall (PIERS - FALL)*, Singapore, 2017, pp. 55-59.
- [49] <http://www.emtalk.com/mpacalc.php>
- [50] M. A. Nassar, H. Y. Soliman, A. Ghoneim and S. Abuelenin, "Beam steering antenna arrays for 28-GHz applications," *Loughborough Antennas & Propagation Conference (LAPC 2017)*, Loughborough, 2017, pp. 1-4.
- [51] M. Ikram, Y. Wang, M. S. Sharawi and A. Abbosh, "A novel connected PIFA array with MIMO configuration for 5G mobile applications," *2018 Australian Microwave Symposium (AMS)*, Brisbane, QLD, 2018, pp. 19-20.
- [52] A. F. Kaeib, N. M. Shebani and A. R. Zarek, "Design and Analysis of a Slotted Microstrip Antenna for 5G Communication Networks at 28 GHz," *2019 19th International Conference on Sciences and Techniques of Automatic Control and Computer Engineering (STA)*, Sousse, Tunisia, 2019, pp. 648-653
- [53] I. Gharbi, R. Barrak, M. Menif and H. Ragad, "Design of patch array antennas for future 5G applications," *2017 18th International Conference on Sciences and Techniques of Automatic Control and Computer Engineering (STA)*, Monastir, 2017., pp. 674-678.
- [54] W. Hong *et al.*, "Multibeam Antenna Technologies for 5G Wireless Communications," in *IEEE Transactions on Antennas and Propagation*, vol. 65.