



**Bachelor of Science in Electronics And
Telecommunication Engineering**

**Vehicle accident prevention detection and emergency
response using wireless technology**

Submitted by

Nur Mohammad Al Kawsar

T-181007

Mohammad Rayhan Hossen Murad

T-181029

Supervised by

Mohammed Ibrahim

Assistant Professor

Department of ETE

International Islamic University Chittagong

Department of Electronic and Telecommunications Engineering
International Islamic University Chittagong
Kumira, Sitakunda, Chattagram

DEDICATION

This thesis is dedicated to all of our honored parents and teachers.

CERTIFICATE OF APPROVAL

The research project, "Vehicle accident prevention detection and emergency response using IoT technology," submitted by Rayhan Hossen Murad(T-181029) and Nur Mohammad Al Kawsar(T-181007) to the Department of Electronic and Telecommunications Engineering (ETE) of International Islamic University Chittagong (IIUC) has been accepted as satisfactory for the partial fulfillment of the requirements for the Degree of Bachelor in Electronic and Telecommunication Engineering.

Approved by

Mohammed Ibrahim

Supervisor

Assistant Professor

Department of Electronics and Telecommunications Engineering

Faculty of Science and Engineering

International Islamic University Chittagong

Kumira, Sitakunda, Chittagong.

CANDIDATES DECLARATION

The work described in this thesis has not been submitted anywhere for the granting of any degree or diploma, and it is being declared that it does not contain any statements that are illegal.

1. Nur Mohammad Al Kawsar

T-181007

2. Mohammad Rayhan Hosen

Morad T-181029

Acknowledgements

In the name of Allah, the Most Forgiving, the Most Merciful. All thanks and glory belong to Allah (SWT), who has provided us with a wealth of chances and showered us with His mercy and guidance throughout life. And may Allah's peace and blessings be upon His Prophet Muhammad (pbuh), who has been a source of wisdom and inspiration for us. We sincerely thank and owe our thesis advisor, IIUC Mohammed Ibrahim sir, lecturer in the Department of Electronic and Telecommunications Engineering, for his initiative in this area of study, insightful advice, and support throughout the research process. We also praise him for giving us the greatest facilities in the division and for his prompt advice. We also appreciate Mohammad Abdul Gafur sir, our thesis' convener, for his commitment and sacrifice. We also want to sincerely thank all of our teachers for their dedication to us during the course of our academic careers. We also think back on how much our parents have helped us throughout our lives. Additionally, we thank our friends and well-wishers for helping us finish this thesis work, whether directly or indirectly.

Abstract

Road accident is a very unwanted incident to all road users. We all have to travel in road by vehicle. The safety of vehicle is a very desired thing. We all know that technology is being advancing recently. In this study we proposed a system which will prevent vehicle from accident, if accident occurred it will detect accident and notify to registered person. To accomplish our desired outcome. We build an LED display using 12 LED pin to cover all direction of vehicle each direction has 3 light to indicate distance between the host and other vehicle. The LED light glow on the basis of distance. If vehicle get vibrated or overturned the accelerometer detect accident occurred and it will send message to registered person. The number of registered is included in GSM module by code. Our proposed LED light display has many benefits beside prevention of accident like blind spot detection, overtaking of vehicle, breaking distance measurement.

TABLE OF CONTENTS

Contents

Contents

Chapter: 01	9
Introduction.....	9
Overview of the problem:	10
Accidental History in Bangladesh	11
Risk Factors of vehicle's clash:.....	11
Significance of study.....	12
Research Objectives:	13
Chapter 2	15
Technical Description	15
Elements Of Wireless Technology:	15
Evolution of wireless technology:	16
Feature of Wireless Technology:	16
Advantage of wireless Technology:.....	17
Disadvantage of Wireless Technology:.....	17
Applications of wireless Technology:	18
Future of wireless Technology:	18
Global Positioning System:	19
Wireless Technology In Accident prevention, detection and response system:	19
Arduino:.....	20
Ultrasonic sensor:.....	21
LCD Display:.....	21
Chapter: 03	28
Literature Review	28
A comparison study of above mentioned research papers.....	33
Chapter: 04	34
Proposed Design.....	34
Proposed Design:.....	34
System Design:	35
Accident Prevention:	35
2) Accident Detection:.....	36
3) Emergency Response:	37
Circuit Diagram:.....	38
Components required:	38
Circuit Pictures	39
Circuit Description:	41
Program Code:.....	42
Chapter: 05	43
Results	43
Accident detection and Emergency Response:	44
Conclusion	45
Future scope of this work:.....	45
References.....	47

LIST OF FIGURES

Figure 1 Figure 1: Road accident rates in Bangladesh	11
Figure 2 Elements of Wireless Technology[10]	15
Figure 3 LED light	23
Figure 4 accelerometer	24
Figure 5 GSM module	25
Figure 6 GPM Module	26
Figure 7 Multimeter	27
Figure 8 Code for accident detection	36
Figure 9 Circuit Diagram	38
Figure 10 circuit diagram	38
Figure 11 LCD display	39
Figure 12 Accelerometer sensor	39
Figure 13 Accelerometr and display	39
Figure 14 Main Diagram	39
Figure 15 LED light display.....	40
Figure 16 LED light.....	40
Figure 17 Power source.....	40
Figure 18 Code.....	42
Figure 19 Output Display	43
Figure 20 Output display 2	44
Figure 21 Output display 3	44

Chapter: 01

Introduction

Modern transportation systems have largely adopted advanced vehicle safety technologies, which are anticipated to improve traffic safety. However, less effort has been taken to determine the impact of vehicular technology on the traffic stream, with the major focus of these technologies being on assisting specific vehicles that are equipped with them. This study presented a technique to reduce the accidental events of vehicles, a technology that holds promise for reducing injury severity and preventing traffic accidents. (jeong, n.d.) Multiple sensors are used by collision avoidance technology systems to give drivers awareness of their immediate surroundings. These systems can detect nearby objects or other cars and road users, such as pedestrians and cyclists. (Centre for road safety, n.d.) Vehicles equipped with collision avoidance systems are less likely to be involved in collisions that result in injuries, according to the Institute for Highway Safety. It has been demonstrated that this safety technology lowers fatalities, serious injuries, and auto accidents. [1]

Incorporating technology in vehicles is essential nowadays. To help riders, passengers and pedestrians to make life more safer. In this study we tried to build a project and express our views on that topic. Studied lots of recent papers on the particular issue.

How sensors are being used and it helps riders and passengers recently we saw iPhone 14 is being released with a technology accident alert system. Peoples supported on that technology and hoped it will be more effective in future. Others brand also working on that technology to make technology for useful for human life. [2]

So, working in this project it's a very demanded skill to learn more about accident prevention technologies and detection of accidents via different sensors and also

responding at emergency situation. Because people get fear to help an injured person so calling to ambulance automatically is also a part of this project.

Overview of the problem:

Nowadays transportation has become a part and parcel of life. No one can think life without it. At the same time transportation also responsible for deadly damages. Transportation not only for peoples but also for goods, important documents, animals. Any material shifting to a new place to another. Vehicles transportation is the most useful way of transportation.

As it is very crucial so there must be a secure transportation is required. Recently technology making life easier more comfortable accessible and easier. It is possible to build a technology which will assist in secure vehicle transportation.

Road accident causes many damages taking form vehicles to life including goods, environment polluted gas, medicals, injuries, road blocks, victim families to hamper. So harms causes by road accident which is uncountable and very pathetic.

This problem is literally a great concern so taking action against it must be necessary. Minimizing clash in road must be a great initiative. In this search we tried to build a technology which will assist to avoid collision among vehicles, in case any collision happened it will notify by texting or calling. To achieve this. We chossed IoT, IoT is newly emerging technology, IoT is integrated networks of sensors to accomplish a specific task. Prevention of accident using could be a great options using IoT. Many researchers gives their ideas on prevention of accident, detection and emergency response. Similarly we tried to give an easy solution to a great problem.

Accidental History in Bangladesh

There is a rich statistics of road accidental history in Bangladesh. Everyday on average eight person are dying because of road crash. A report is being shown that 60 deaths corresponds to 10,000 bikes. Another report shown that 43% accidents increased between 1982 to 2000 and 400% fatalities expanded at the same period. It means not only accidents increased but severity of accidents also grown. As day by day population are increasing so its expected that road clash will being rising rapidly[3]

Table 1 Road accident rates in Bangladesh

Year	Number of Accidents	Number of Casualties	
		Killed	Injured
1992	4,012	2,317	4,509
1998	3,533	2,358	3,297
1999	3,948	2,893	3,469
2000	3,970	3,058	3,485
2001	2,925	2,388	2,565
2002	3,941	3,053	3,285
2003	4,114	3,334	3,740

Figure 1 Figure 1: Road accident rates in Bangladesh

Figure 1: Road accident rates in Bangladesh

Over the past few years, Bangladesh has seen an alarming increase in the number of traffic accidents. From 2020 to 2021, the number of accidents and fatalities grew steadily. In comparison to January through December of 2020, which had 5,431 fatalities and 7,379 injuries on the roads, at least 6,284 people perished and 7,468 others were injured, according to the Bangladesh Road Safety Foundation's (RSF) annual report.[4]

Risk Factors of vehicle's clash:

A safe transport system for all road users is the aim of the safe system approach to road safety. Such an approach understands that the system should be built to be forgiving of

human mistake and takes into account people's sensitivity to significant injuries in traffic accidents. Safe roads and roadsides, safe speeds, safe vehicles, and safe road users are the cornerstones of this strategy, all of which must be addressed to prevent fatal crashes and lessen catastrophic injuries. (seema, 2022)

1. Speeding,
2. Driving under the influence of alcohol and other psychoactive substances,
3. Not using of motorcycle helmets, seat-belts, and child restraints,
4. Distracted driving,
5. Unsafe road infrastructure,
6. Unsafe vehicles,
7. Inadequate post-crash care,
8. Inadequate law enforcement of traffic laws.

Injuries by traffic can be prevented. Governments must act to address road safety in a comprehensive way. This requires for participation from numerous sectors, including transportation, law enforcement, health, and education, as well as initiatives that address the safety of roads, vehicles, and road users.

Designing safer infrastructure, incorporating road safety features into land-use and transportation planning, enhancing vehicle safety features, improving post-crash care for victims of traffic accidents, establishing and enforcing laws relating to key risks, and increasing public awareness are all examples of effective interventions.

Significance of study

Everyday we hear on news or watches on TV that peoples died on accident, loved one dies people's crying that scenario is not new for us. As technology improving it helping us in life through many ways. So action should be taken to tackle that issue with the help of

technology this study is a little effort to solve that problem. The best way to solve a problem is prevention, we focus on prevention of accident and after that responding for emergency help. As this issue is so critical it has lots of significance, some of them are mention below:

1. A milestone to safety of vehicles, we already knew that vehicles transportation is a basic need to for everyone so securing safety it's mandatory demand to fulfill.
2. Helping passengers, riders to safe their life.
3. Incorporating of technologies in vehicles or modernizing the transportation system.
4. Pre-collision Concept, The pre-collision concept is another technical advance that is concerned with the overall safety of drivers. Additionally, this is solidifying the idea of reducing traffic accidents moving forward. The same technology prompts the motorist if their focus is off the road ahead and somewhere else.
5. Reducing collision or clashes on the road is our very extreme desires so this study support to reduce accidents.
6. In the last ten years, the auto industry has seen significant changes and continues to be developing quickly. As we progress to the concept of a smart city, technologies like artificial intelligence, big data, 5G, and the internet of things are changing the driving experience, improving our roads, and providing safety, comfort, and lower fuel emissions.[5]
7. Studies like this open the door to newly coming technology like Fuel efficiency riders, Predictive vehicle's technology, Self-driving vehicle's, Cars-as-a-service (CaaS) etc. [6]

To improve the way our vehicles run today, some of the brightest minds in the tech sector have collaborated with automotive businesses.

Research Objectives:

This project's primary goal is to stop accidents from occurring because of excessive vehicle proximity, overtaking, and crowded conditions. The employed electronic devices will

undoubtedly be able to communicate a spontaneous message and the precise location to the police and ambulance in order to locate the victim if the accident occurs due to other circumstances.

Some of them are pointed as:

1. Creation of a technology to help prevention of vehicles accidents.
2. Detection of an accident through technology to
3. Informing to responsible bodies at emergency situation.
4. It's life a saving technologies
5. It is a safety technology for vehicle's
6. Minimizing road clashes among vehicles
7. Advancing to vehicle industry through technology.
8. An easily installing setup which has less technical difficulties.
9. Able to support any vehicles, not specified to a particular genre
10. An IoT based projects also using advanced technology.

Chapter 2

Technical Description

Wireless Technology: Wireless technology is any technology that enables communication without the use of wires or cables. People and other things can communicate over very vast distances with this kind of technology. In wireless technology, RF and IR waves are used. The terms "radio frequency" and "infrared," respectively, [7]

Through the use of wireless technology, two or more entities can communicate with one another over distances without the need for any kind of wires or cables. Both radio frequency (RF) and infrared (IR) communications are included in this. [8]

Elements Of Wireless Technology:

The three components of a typical wireless communication system are the transmitter, the channel, and the receiver. The block diagram of a wireless communication system is displayed in the following image. [9]

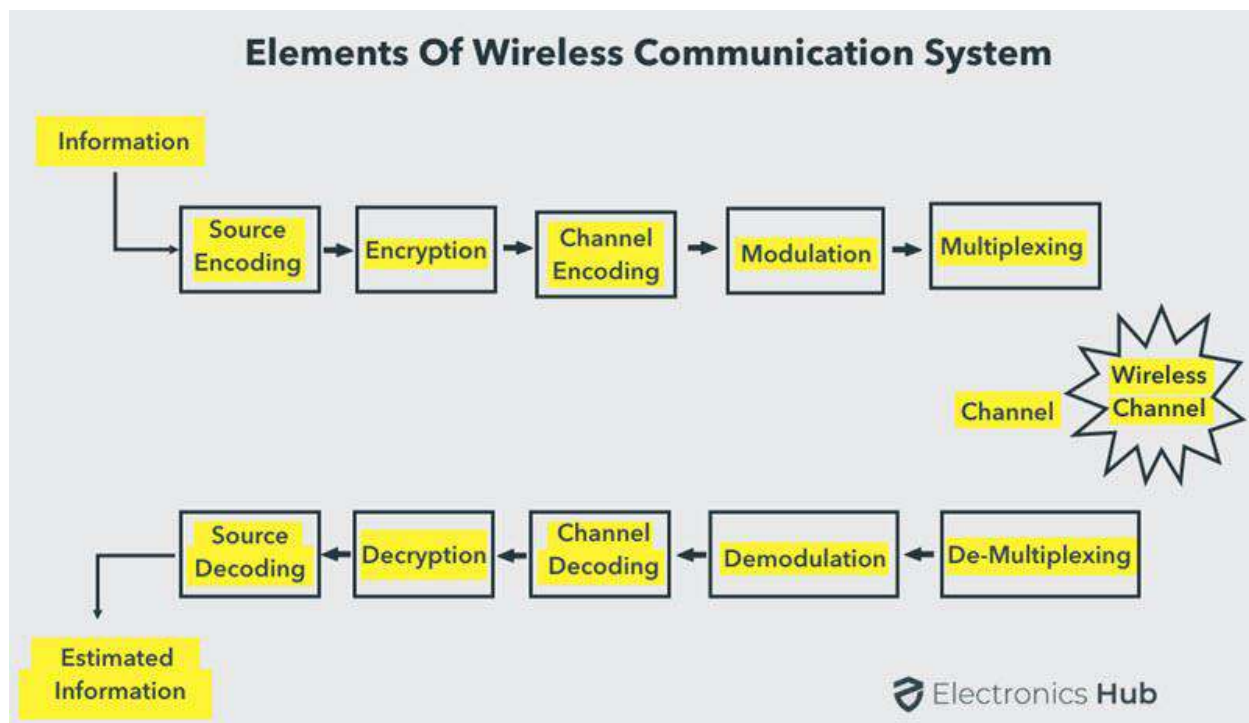

Figure 2 Elements of Wireless Technology [10]

Evolution of wireless technology:

Understanding the fundamentals of wireless network technology is helpful before delving into the newest iteration. While much has been accomplished since the 1880s, the following are some of the most significant turning points in wireless communication history:

The telegraph and mobile phones were both developed in quick succession after the discovery of radio waves in 1880.

The first transatlantic radio message was a brief letter sent in 1901 between Britain and Canada.

A framework was built in 1922 with the discovery of FM frequencies and the invention of the portable radio.

In 1970 This infrastructure helped Ethernet and high-speed packet transfers evolve. In 1983, the renowned Motorola cell phone debuts, sparking the development of the 1G network.

The 3G network becomes live in 2001.

Nearly seven years prior to the launch of the first iPhone, the 3G network becomes operational in 2001.

The 4G or LTE network opens in 2007 after more than two years of testing.

During the 2018 Olympic Winter Games in South Korea, Intel will be bringing its 5G network.

As seen, businesses in the telecom sector are constantly coming up with new ideas.[10]

Feature of Wireless Technology:

With its useful qualities, wireless technology has evolved to bring about several improvements.

The transmitted distance can range from a few meters (for instance, the remote control of a television) to thousands of kilometers (for example, radio communication).

Cellular telephony, wireless internet access, wireless home networking, and other uses for wireless communication are all possible.

GPS devices, garage door openers, wireless computer mouse, keyboards, and headsets, headphones, radio receivers, satellite television, broadcast television, and cordless telephones are more examples of applications for radio wireless technology.[11]

Advantage of wireless Technology:

Improved Efficiency: Faster data flow between partners and customers as well as within enterprises results from improved data connectivity. On sales calls, for example, salespeople can use this to remotely check stock levels and prices.

Better coverage and mobility: You are confined to one place by wires. By going wireless, you can move around without losing your connection and even connect to office networks without using additional cables or adaptors.

Flexibility: While away from the workplace, wireless office workers can still be productive because they can be networked without using a dedicated computer. New working practices, such working from home or having direct access to corporate data while on the premises of a client, could result from this.

Cost saving: Installing wireless networks can be simpler and less expensive, especially in older structures or if the landlord forbids the installation of cables. Costs are lower because there are fewer wires and cables. The comparatively low cost of wireless routers, the lack of the necessity for trenching, drilling, and feeding wires inside walls, as well as other physical connection techniques, all contribute to this. Additionally, there is no need for wire maintenance.

Adaptability: Devices can be integrated into networks quickly and easily, and installations may be modified with great flexibility.[12]

Disadvantage of Wireless Technology:

Communication is less secure because it takes place in a public setting.

Unreliability more susceptible to intrusion. Increased likelihood of jamming

Comparably, the transmission speed is slower.

It has constrained communication bandwidth and is vulnerable to security vulnerabilities on the network.

Wireless networks are vulnerable to hacking.

When wireless networks are installed, special consideration must be given to radio frequency.

Although installing a wireless network costs a lot of money, wireless networks are typically inexpensive.[13]

Applications of wireless Technology:

Security systems, television remote controls, Wi-Fi, cell phones, wireless power transfer, computer interface devices, and numerous wireless communication-based projects are examples of applications for wireless communication. Projects based on wireless communication typically use a variety of wireless communication technologies, such as Bluetooth, GPS, GSM, RFID, and Zigbee.[14]

Future of wireless Technology:

Ad-Hoc Networks:

A WLAN known as an ad-hoc network allows mobile or portable devices to connect to the network but only when they are in close vicinity. Information is transmitted utilizing multihop routing in a peer-to-peer method with no established infrastructure. Ad-hoc networks can be used by a group of nearby soldiers to share information between their notebook computers utilizing RF waves.[15]

Sensors Network: The most recent wireless networks are sensor networks, which use a large number of sparse, immobile sensors to be placed randomly around an area in order to sense and broadcast certain environmental physical characteristics. A "data centric basis" is used to aggregate the sensor data.[16]

Global Positioning System:

Global Positioning Systems (GPS) are space-based radio positioning systems that may be used by users with the appropriate equipment anywhere on the surface of the Earth to deliver 24-hour, three-dimensional position, velocity, and time information. The first GPS system that enables intelligent vehicle tracking and navigation is the NAVSTAR system, which is run by the US Department of Defense. It can be used for a variety of military purposes, including target localization and information gathering, command and control, mine detection, testing combat aircraft, missile guidance, and artillery pointing, to mention a few. With the use of GPS, surveys may be conducted in practically any weather. Both search and rescue operations and precision farming in agriculture can benefit from GPS technology. In cars, GPS-based navigation has been made available by automakers. A four-inch monitor asks drivers where they're going, shows a color map of the neighborhood, and scrolls down a list of pre-selected areas of interest like hotels, conference centers, or a particular street address.[17]

Wireless Technology In Accident prevention, detection and response system:

Now a days wireless is being used to detect accident ,prevention and response system in worldwide among many car manufacturing company. During and after crashes, an accelerometer has been employed as a vehicle's crash or rollover detector. When a violent collision is detected using accelerometer signals, the vibration sensor sends a signal to the microcontroller, which then activates the GPS-GSM module. The GPS module will use the GSM module to transmit the vehicle's real-time satellite coordinates to a website where the operator may observe the accident's locations and dispatch assistance if needed. To determine the system's efficiency in handling collision detection, the full system is simulating. [18]

Arduino:

The single-board microcontrollers and microcontroller kits for creating digital devices

are designed and produced by Arduino, an open-source hardware and software company, project, and user community. While its software is distributed under the GNU Lesser General Public License (LGPL) or the GNU General Public License (GPL), the company's hardware products are licensed under the Creative Commons Attribution-Share Alike (CC BY-SA) license, allowing anyone to produce Arduino boards and distribute the company's software. From the official website or through accredited dealers, Arduino boards are available for purchase.

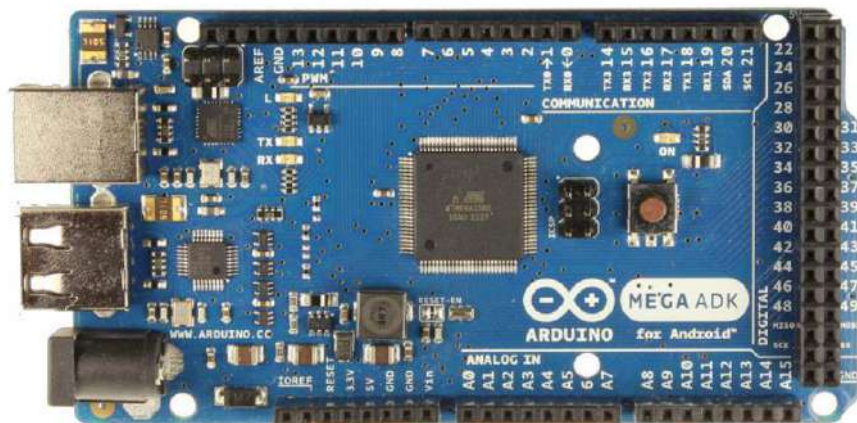

Figure 4 Aurdunio Mega

Different types of microprocessors and controllers are used in Arduino board designs. The boards have a variety of extension boards (called "shields"), breadboards (for prototyping), and other circuits that can be interfaced to the sets of digital and analog input/output (I/O) pins on the boards. The boards have serial communications interfaces, some of which support USB (Universal Serial Bus), which are also used to load programs. The C and C++ programming languages, as well as a standard API known as the Arduino language, which was modeled after the Processing language and used with a modified version of the Processing IDE, can be used to program the

microcontrollers. The Arduino project offers an integrated development environment (IDE) and a command line tool created in Go in addition to using conventional compiler tool chains [19]

Ultrasonic sensor:

An ultrasonic sensor is a piece of technology that uses ultrasonic sound waves to measure a target object's distance and then turns the sound that is reflected back into an electrical signal. The speed of audible sound is greater than the speed of ultrasonic waves (i.e. the sound that humans can hear). The transmitter (which generates sound using piezoelectric crystals) and the receiver are the two major parts of an ultrasonic sensor (which encounters the sound after it has travelled to and from the target).[20]

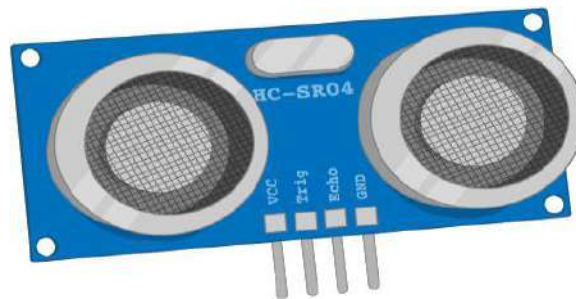

Figure 5 Ultrasonic Sensor [21]

LCD Display:

"Liquid Crystal Display" is referred to as LCD. In TVs and computer monitors, LCD is a flat panel display technology that is widely utilized. Additionally, it is utilized in the screens of mobile gadgets including laptops, tablets, and smartphones.

In addition to looking different than clunky CRT (Cathode Ray Tube) monitors, LCD screens also perform very differently. An LCD has a backlight that supplies a light source to individual pixels organized in a rectangular grid rather than shooting

electrons at a glass panel. Red, Green, and Blue (RGB) sub-pixels are present in every pixel and can be turned on or off. It appears dark when all of a pixel's sub-pixels are off.[22]



Figure 6 LCD Display[23]

LED Light:

Light-emitting diode is what it stands for. Up to 90% more light is produced by LED lighting devices than by incandescent bulbs. How do they function? Visible light is produced when an electrical current flows through a microchip and ignites the tiny light sources known as LEDs. The heat that LEDs emit is absorbed into a heat sink to prevent performance difficulties.[24]

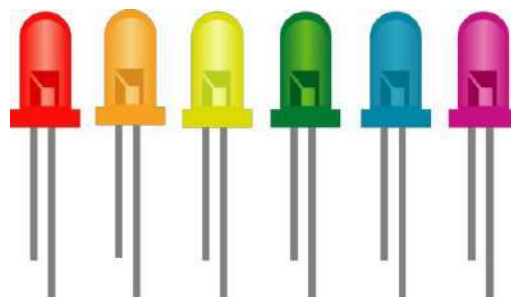

Figure 3 LED light

Figure 1.4: LED Light [25]

Accelerometer:

An electrical sensor called an accelerometer monitors the acceleration forces acting

on an object in order to pinpoint its location in space and track its motion. The rate of change in an object's velocity is known as acceleration and is a vector quantity (velocity being the displacement of the object divided by the change in time).

Acceleration forces come in two flavors: static forces and dynamic forces. Static forces are those that are continually exerted on the object (such as friction or gravity). Dynamic forces are "moving" forces that are used to affect an item at different rates (such as vibration, or the force exerted on a cue ball in a game of pool). Because of this, accelerometers are employed, for instance, in automotive accident safety systems. When a car is subjected to a strong dynamic force, the accelerometer—which detects a sudden deceleration—sends a signal electronically to an embedded computer, which then inflates the airbags.[26]

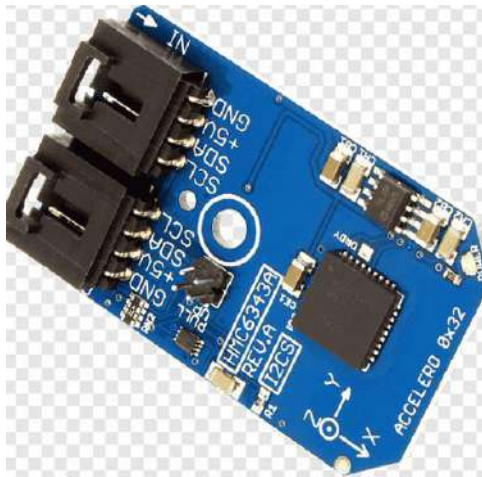

Figure 4 accelerometer
[26]

GSM Module:

Cellular communication networks use the Global System for Mobile Communication (GSM) standard. The GSM standard is one of the most widely used cell technologies today.

GSM modules provide wireless data communication and connectivity. These gadgets are small, portable, and surprisingly power-efficient for the amount of work they can accomplish. In addition to many other uses, they can be used to track communication projects, connect a remote site monitoring system with your LAN, and more.

A GSM module is a specific kind of device that uses a SIM card and requires a mobile operator subscription to function, much like a cell phone or pager. A GSM modem resembles a phone from the perspective of a mobile operator. The ability to run more applications on a module makes it different from a cell phone.

Because cellular connections do not require a special subscription to a different service provider, they can be a quick and effective way to begin using SMS notifications in network monitoring solutions. Since GSM modules use existing networks, they are generally more affordable than expanding your infrastructure to include hardware that enables direct connections with your remote sites for sending and receiving alarm notifications.[28]



Figure 5 GSM module

GPS Module:

Global Positioning System is known as GPS. Both satellites and ground-based

control installations are part of the system. A surface-mount chip in a GPS sensor interprets signals from GPS satellites using a tiny rectangular antenna, which is frequently positioned on top of the GPS chip.

- A GPS module is often a tiny board on which the GPS sensor and other components are placed.
- A GPS receiver is a device that also has a data display and other parts, such as a memory for data storage.[30]



Figure 6 GPM Module

Multimeter:

A multimeter, commonly referred to as a volt-ohm meter, is a portable tester used to gauge resistance, voltage, and other electrical quantities. Multimeters are useful for a wide range of tasks, from straightforward testing, such as gauging battery voltage, to problem finding and intricate diagnostics. They are available in analog and digital variants. When diagnosing electrical issues with motors, appliances, circuits, power supply, and wiring systems, they are one of the tools electricians favor.[32]



Figure 7 Multimeter

Chapter: 03

Literature Review

The author of this paper shows, An accident prevention and detection system has been built for vehicles. The author tries to signify the problem of accident occurrence and action taken after in response. Sometimes if we take proper step at that situation calling to ambulance the victim could get saved his life. So it's crucial and life saving technology. They build an IoT based technology where they used accelerometer to check head movement of drowsiness driver. GSM and GPS module for sending messages and location of vehicles to registered person. Besides they used smoke sensor to check smoke and vibration sensor to help accident detection. They also used a motor to reducing speed when other vehicles get close to, the distance is measured by ultrasonic sensors. All these sensors equipped with Arduino to build a system to assist vehicle on accident preventing and emergency response.[34]

This paper focuses the accident prevention from drunken driver, whenever any drunken person try to drive the vehicles it wouldn't take ignition. They optimize their system as such that it check if a driver is drunken or not. They believe that most the accidents occurs because of drunken driver. In their system they used alcohol sensor for drunk detection, DC motor showing as vehicle engine to make automated stop for drunken drivers. A heart beat sensors equipped in driver sit belt to mechanize therapeutic crisis. This paper signifies accident avoidance from drunken driven from various angles.[35]

They build an accident prevention method in hairpin bend road, or at hilly track. Most of the accident occurs at bend area of road because both vehicles doesn't know their presence and they get collided with each other. The idea given in this paper is that in the both sides of road they installed ultrasonic sensors and LED whenever a vehicles comes to other side of road LED will blink that's how driver will know if any vehicle has presented and they also used GSM and GPS sensor which help if any accident occurs it will notify to nearby hospitals by giving location.[36]

They build an IoT tech-based accident detection and reporting system. Many sensors embedded with vehicles which helps rider not only present situation of vehicle but also surroundings and help against accidents. They build an app to know the information of speed, gravitation force, pressure, sound and location, for detection of accident speed is a key parameter. Collecting these data from mobiles sensors and sending it to web servers and notification system is also added to notify the selected person when configuring the app and notifying to nearby hospitals through GPS. The special things of this paper is they didn't create any external hardware system to support their idea rather they used smartphone sensors to facilitate their proposed system. This system fully based on IoT. The functionality of how an IoT system works, It's depict of proposed system. Explanation of that projects at each layer helps reader to understand it properly. Many business organization trying to build such system to detection precisely and response system, most of them build at hardware level makes them expensive along technical trouble issues, considering a situation where the detection device get damaged at accident occurring so there will be means of using such system, therefor they seems choosing smartphone is a nice option. [37]

This paper proposed an accident prevention method, whenever any vehicles get close to another the vehicles give alarm the driver with LED light nearby vehicles showing with distances. They used many cameras to see vehicles around vehicles. That is how they create prevention scheme using sensors, and Arduino. They also integrated GSM module to notify if accident occurred. This smart system is useful for rider to safely drive their vehicle. Accident information is not only sent to registered number but nearby police station and hospitals to help the victim. Their idea is simple and short but they used many sensors which unnecessary and costly four camera would be very expensive to integrate in projects. [38]

Preventing fatalities from hilly terrains became an issue of research, the paper proposed a system that alerts the driver of the vehicle on one side of the road so that another driver will be notified using LED light. Ultrasonic is the key element to implement this idea. If an ultrasonic sensor senses the vehicle from one side, it will blink the LED light to the other side. The given idea has two significant problems, one is if a car crosses a side of the road when it reaches the other end the LED will be blinking, so the car will blink the LED for twice which is a false alarm, second is if any vehicles are stopped nearby on a curved part of the road, the LED keeps blinking. So they solved the problem using programming in a micro-controller. They used two extra green lights to solve the issues. When any vehicle crosses the other end after crossing the first one at a second time the green LED will be blinking, which is a positive sign for the other end of the vehicle.[39]

Quantifying the Effectiveness of IoT Technologies for Accident Prevention,,

IoT improved sensors technologies and wireless internet. It has lots of applications such as Health-care, Logistics, Manufacturing, Smart Homes and smart cities are the common areas of IoT implementation. A research found that IoT can help in construction sites for accident prevention. Many wearable instruments, helmet equipped with different sensors give helpful information regarding the safety of workers. At very recent studies show that IoT has been used in many safety management technologies and their applications. A large portion of them are reducing accident events. This paper developed a method to measure the efficiency of IoT technologies at construction to reduce accidental cases. It helps the user to justify or encourage to use safety gear properly.[40]

A blind spot of vehicles causes accidental events such as automobile collisions, obstacles and many more. To tackle this issue researchers proposed protection against blind spots using technologies, if obstacles are detected by ultrasonic sensors putting that in blind spot an LED will blink at a given display meter,

They named it BSAPS (Blind spot Accident Prevention System), Several research is being done for eliminating damage caused by blind spots. They proposed a system using ultrasonic

sensor to avoid collision caused by blind spot that consist an audible alarm, LED meter, time delay circuit are primary components of building that system.[41]

Developing countries or low income afford two-wheelers than four wheelers but there is more accidental case for two wheeler comparing to four-wheeler, Probable cause are not using helmet, alcohol consuming, drowsiness, riding vehicles close proximity, not abiding traffic rules,even not having proper license, these are very common reasons why two-wheeler happen mishaps. They build a system which check detection by vibration sensors, accelerometer for detection, GPS and GSM for location of spot and informing registered person and nearby hospitals by sending text message. It also determines whether the driver is drowsy or in an unable to drive state, which can cause pedal confusion and, in some cases, unintended acceleration or turning of the steering wheel in the wrong direction, resulting in a collision with another vehicle or a concrete road barrier.[42]

Radar is a technology for detecting objects that uses radio waves to calculate an object's distance, altitude, direction, or speed. But today, it can be used to avert mishaps in a variety of geological and climatic conditions, such as mountainous areas, beyond just detecting aircraft, ships, satellites, guided missiles, etc.

regions and the terrain, particularly the national highways in various sections of the nation that are hit by heavy.

During the winter, there is often extremely little room for mistake and even greater smog, which can be lethal. In their project, they concentrated on an overview of and talking about how our Arduino radar system functions.[43]

Accident prevention and safety assistance using IOT and machine learning,,

Our daily life heavily rely on transportation, whose advancement has made many of our tasks much better. However, in recent years, distracted driving, speeding, and drowsy

driving have all contributed to deadly road accidents.

Alcohol use, drowsiness, and other disruptive behaviors require the driver to be made aware of them in order to avoid an accident. In order to prevent accidents and assist drivers with safety, a prototype is created in this study employing a Raspberry Pi, a Pi Camera, and sensors for tracking eye movements, yawning detection, poisonous gas detection, and alcohol intake. Vehicles now have Internet of Things and machine learning-enabled systems that send the driver's behavior and driving patterns to the cloud so that emergency situations can be handled quickly. A sound system that is designed to warn the driver of potential distractions can save many lives by doing so. Through the collected and stored dataset from cloud services, machine learning and cloud services are used to identify fatigued drivers. Experimental testing of the device demonstrates its effectiveness and efficiency.

In the summary, studying the above mentioned papers, many researchers show their works on different areas of concerns. There works contains multiple technologies. But when it comes to applying a technology many consideration should be made like costing, work efficiency, exaggerated hardware so in our project we at first tried to embed different technology but it would be sophisticated as a project so we build a system which is very simple in technology, cost efficient, made it workable as much as possible aligning with real life. A comparison should be made on the basis of different things. [44]

A comparison study of above mentioned research papers.

Ref.	Features	Limitations	Tools (sensors)
[1]	Emergency response after accident occurrence	System became complex	Main sensors are GPS & GSM
[2]	Detection of drunken drivers, Automate stopping ignition,	But only specifies on drunken drivers	Alcohol & heartbeat sensor
[3]	Preventing accident at bending road, hilly road	Significant limitation there has a chance of double indication of a vehicle	Ultrasonic sensors , LED light
[4]	Accident Reporting system, App showing the vehicles conditions		All basic phone sensors like: Speed, Pressure,GPS
[5]	Alerting rider giving him surroundings information	Overwhelmed by Sensors,	Camera & ultrasonic, GSM, GPS
[6]	Accident prevention from hilly road, Helping rider with nearby vehicles	Issues of False alarming	Ultrasonic sensors, LED
[7]	Quantifying the effectiveness of IoT tech in Construction sites		Comparison studies of different papers
[8]	Display will show vehicles in blind spot	Detection of Blind spot by sensors could be tricky	Ultrasonic sonic sensors, LED display
[9]	Accident Prevention for bikers, signifies on important issues	Implementation could be hard	Smoke, gas, camera, GPS, GSM
[10]	Use of Radar technology for accident preventing form smog	There could be many limitations they didn't mentioned	Ultrasonic sensors,
[11]	Emergency response, Able to recognize driver behavior by the help of Machine learning	Only applicable when internet is on	Machine learning tools, Camera

Chapter: 04

Proposed Design

Proposed Design:

Safety in vehicles is necessary for its riders and passengers. Incorporating technology to avoid collision is became hot research, Many researches shows their ideas and implementation of ideas in vehicles in different area of concerns, We tried to show an idea of preventing vehicles from accident.

Our proposed design is putting ultrasonic sensors around a vehicle if any vehicle or Objects comes to its proximity the LED display shows the distance of other vehicles by indicating by LED light. The LED light display designed as with distance showing with light, how far the other vehicle and objects from our system's car.

With the help the display the rider will be able to know the vehicles around him.

Another feature of this design is if the vehicle got accident the system will call and send sms to registered person along sending GPS

coordinates. If we put these coordinates to any map application, it will show the place where accident happened. Accident occurrence will be determined by accelerometer. A fixed threshold valued will be coded as to determine accident occurrence, when system detects accident happened it will automatically send sms and GPS location to registered person.

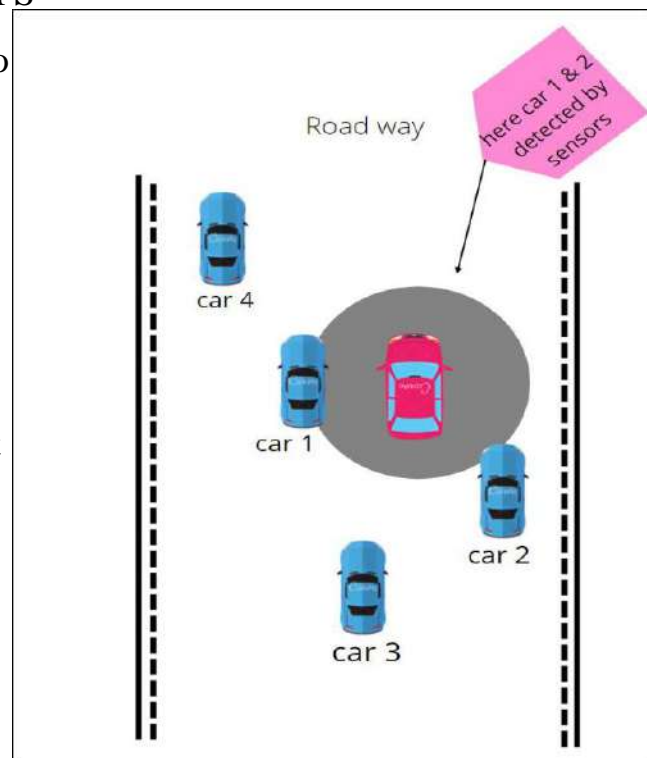

Figure 11 Proposed Architecture

System Design:

The proposed system has three parts:

- 1) Accident Prevention ,,
- 2) Accident Detection &,,
- 3) Emergency Response.

Accident Prevention:

To avoid collisions vehicles from one another we designed an ultrasonic & Led's using to avoid close proximity of vehicles from one another. The Ultrasonic sensors placed as it cover the four side of vehicle to notify the system what are surrounded by it. If any vehicle come closer to system's vehicle the ultrasonic sonic sensor always measuring distance to its facing side. When ultrasonic sensors find any objects it will send it to micro-controller, doing computing the Arduino will blink the light measuring distance the object seen ultrasonic sensor. There are four ultrasonic sensor used to cover the whole vehicles, all ultrasonics works similar. We coded if any vehicle comes to within 30cm the farthest LED will be blinking, if any vehicle comes to 20cm the second nearest LED will be blinking, If any vehicles comes to very close within 10cm the closset LED will be blinking, that's how the rider get notify what are the things surrounded by him.

In this display of LED light indicating 1,2,3 means 1= <10cm,, 2= <20cm, 3= <30cm. If any vehicles come to this range of distances the corresponding light will be blinking.

The four Ultrasonic sensor's covers the all side of vehicles direction.

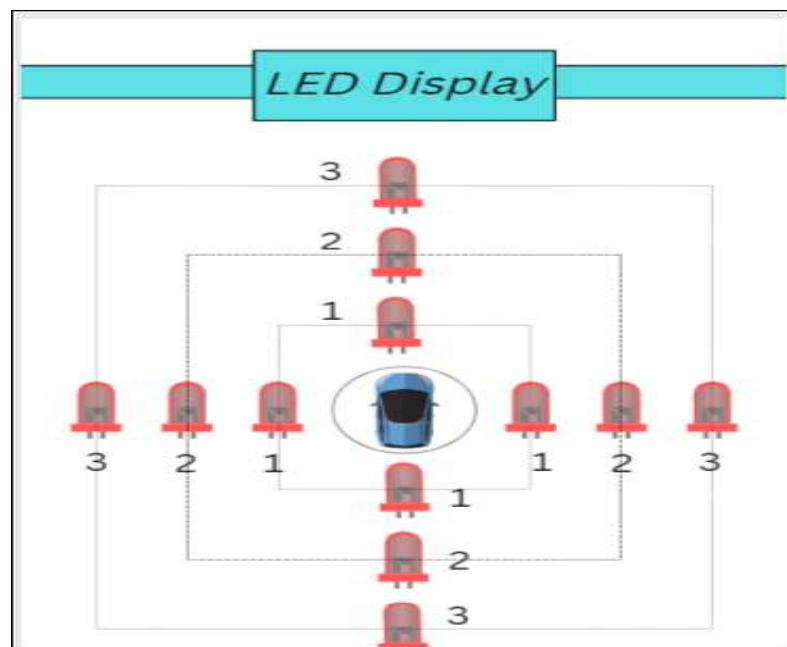

Figure 12 LED display

2) Accident Detection:

Detection of accident occurrence is determined by using accelerometer sensors threshold value of orientation of vehicle is set by code so that if vehicles get rotated irrationally and crossed the limiting values of predetermined by code, accident will be determined.

Accident will be determined by the following values:

Determination of accident is done by a papers namely “Improved Crash Detection Algorithm for vehicle crash detection” in this paper an algorithm is created based on three axis, there is a magnitude value which is related to vibration of vehicles that’s defines whether accident happened or not?

```
void Impact()
{
  //-----
  time1 = micros(); // resets time value
  //-----
  int oldx = xaxis; //store previous axis readings for comparison
  int oldy = yaxis;
  int oldz = zaxis;

  xaxis = analogRead(xPin);
  yaxis = analogRead(yPin);
  zaxis = analogRead(zPin);

  //-----
  //loop counter prevents false triggering. Vibration resets if there is an impact. Don't detect new changes until that "time" has passed.
  vibration--;
  //Serial.print("Vibration = "); Serial.println(vibration);
  if(vibration < 0) vibration = 0;
  //Serial.println("Vibration Reset!");

  if(vibration > 0) return;
  //-----
  deltax = xaxis - oldx;
  delty = yaxis - oldy;
  deltz = zaxis - oldz;

  //Magnitude to calculate force of impact.
  magnitude = sqrt(sq(deltax) + sq(delty) + sq(deltz));
  //%%%%%%%%%%%%%%%%%%%%%%%%%%%%%%%%%%%%%%%%%%%%%%%%%%%%%%%%%%%%%%%%%%%%%%%%
  if (magnitude >= sensitivity) //Impact detected
  {
    updateflag=1;
    // reset anti-vibration counter
    vibration = devibrate;
  }
  //%%%%%%%%%%%%%%%%%%%%%%%%%%%%%%%%%%%%%%%%%%%%%%%%%%%%%%%%%%%%%%%%%%%%%%%%
  else
  {
    //if (magnitude > 15)
    //Serial.println(magnitude);
    //reset magnitude of impact to 0
    magnitude=0;
  }
}
```

Figure 8 Code for accident detection

We experimented in our project we found that 50 is the standard value of detection of accident. The magnitude value is adjusted based the vehicle according to vibration of vehicles. The paper named this as impact function, we used it.

3) Emergency Response:

After detection of accident an emergency response should be made otherwise victim could lose his life. This kinds of event is not new, many people dies every year because of late approaching to hospital. So an emergency response should be added to every vehicles so that life could be saved. To accomplish this we used three sensors accelerometer, GPS anohter GSM. These three module help us to response at emergency time. After reaching to a threshold value, system decides accident occurred now taking gps coordinates from gps sensors ans sms is sent to emergency number, or call, That is how emergency response occurred.

The graph below shows and demonstration of how emergency response will occur.

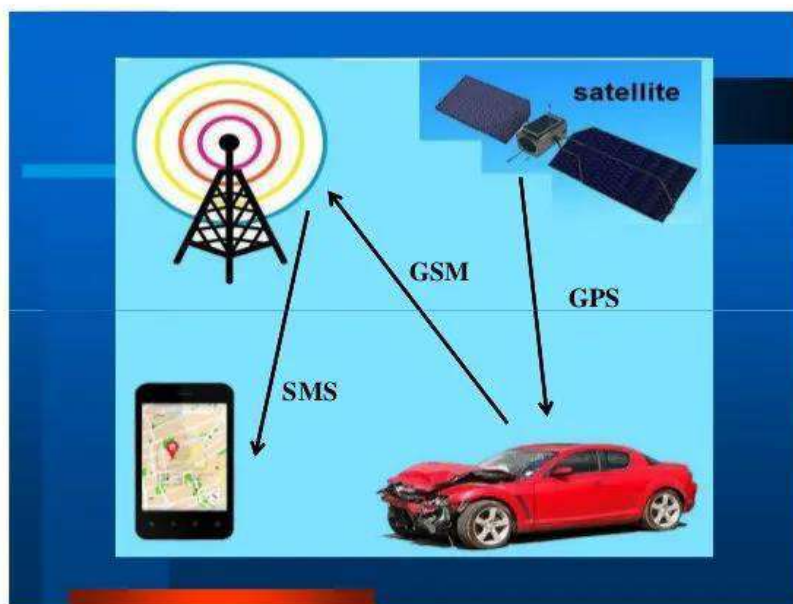

Figure 13 overview of gsm gps working

Circuit Diagram:

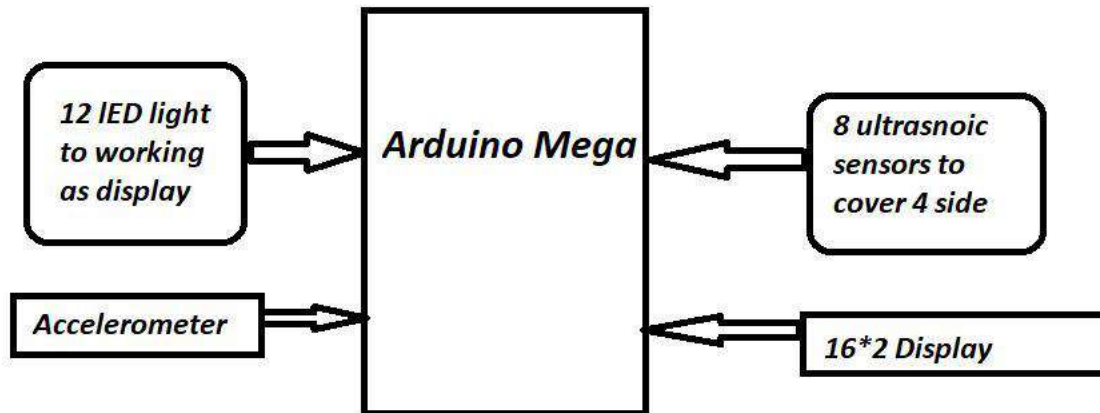

Figure 10 circuit diagram

Components required:

1. Arduino Mega
2. Accelerometer
3. 16*2 display
4. LED light
5. extra circuit throughole board
6. power source
7. Ultrasonic sensors
8. Connecting wires

Circuit Pictures

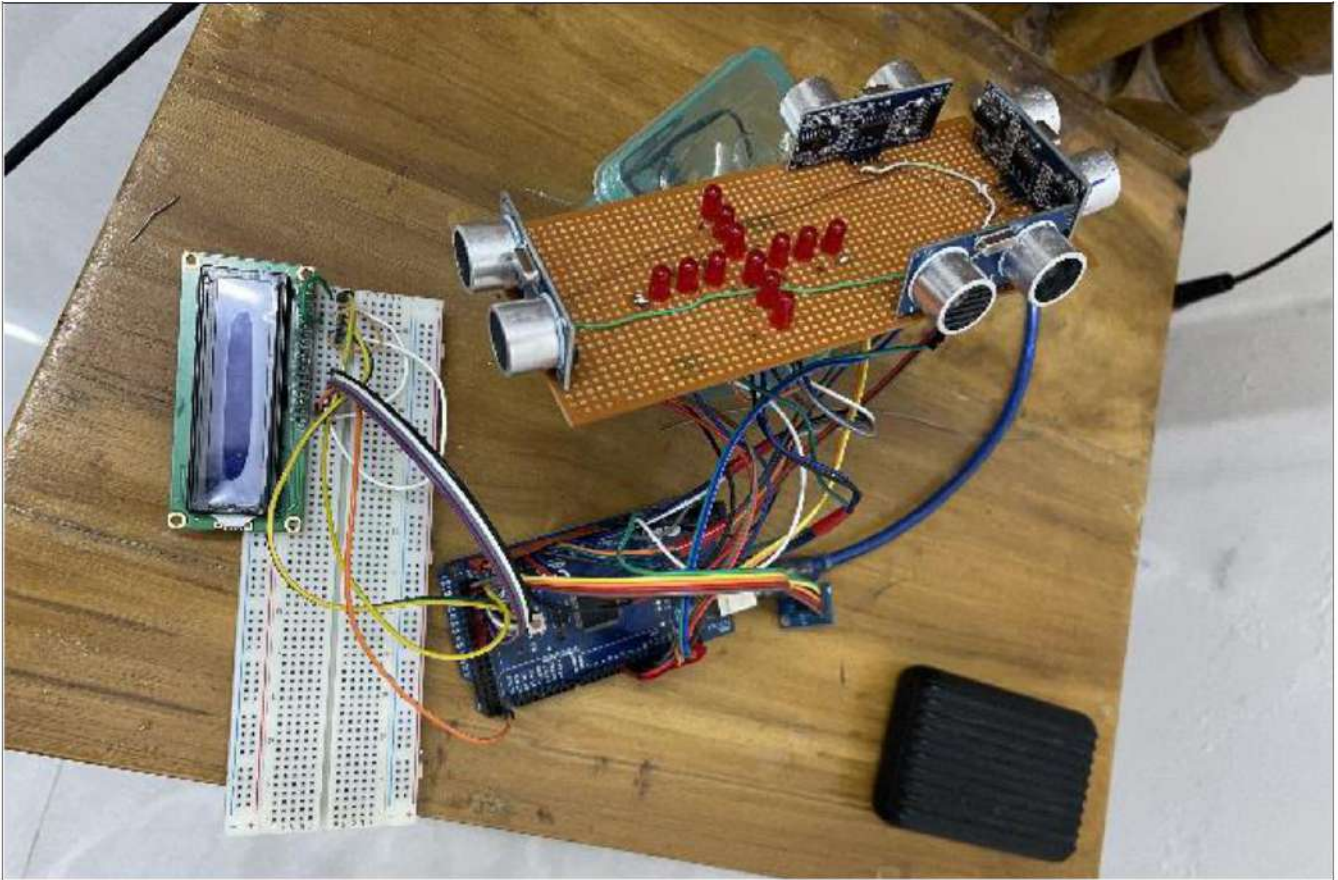

Figure 14 Main Diagram

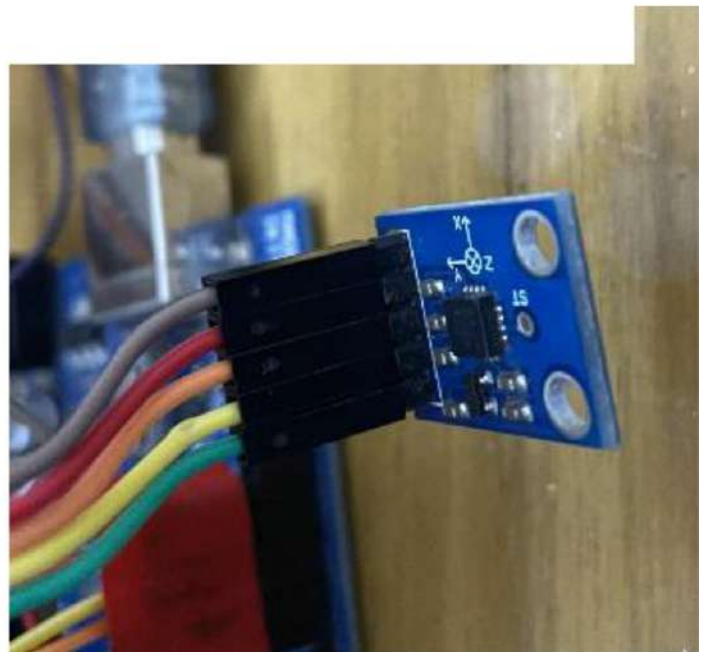

Figure 13 Accelerometr and display

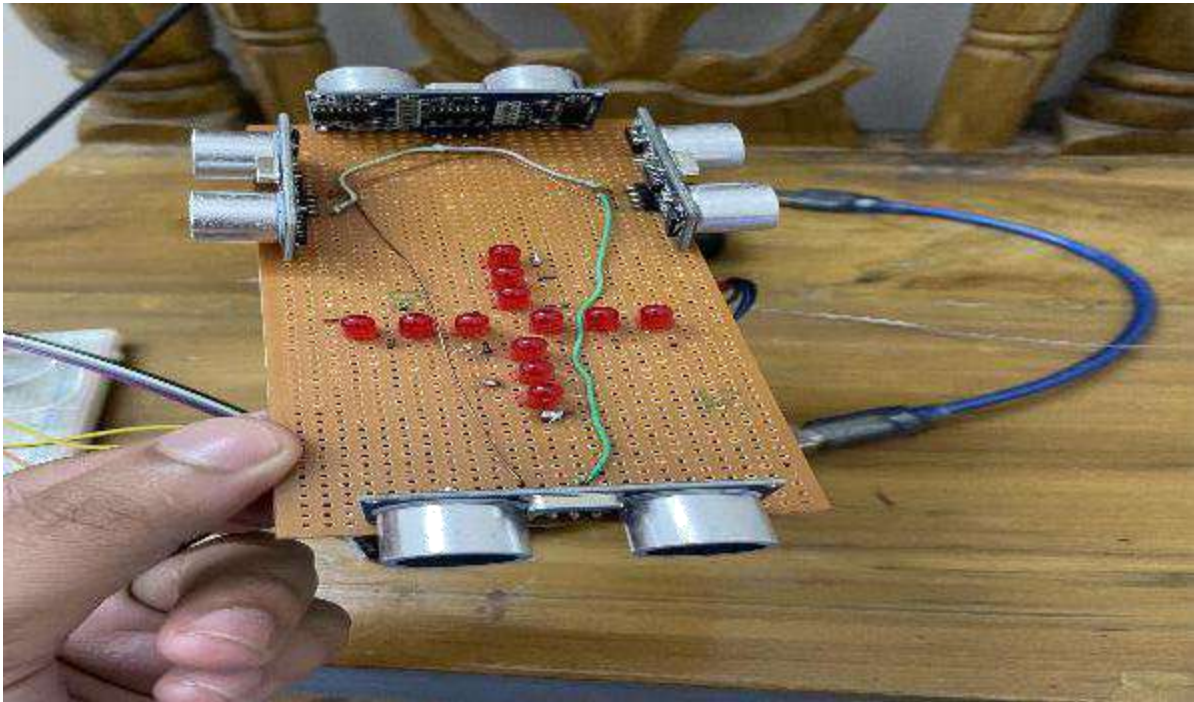

Figure 15 LED light display

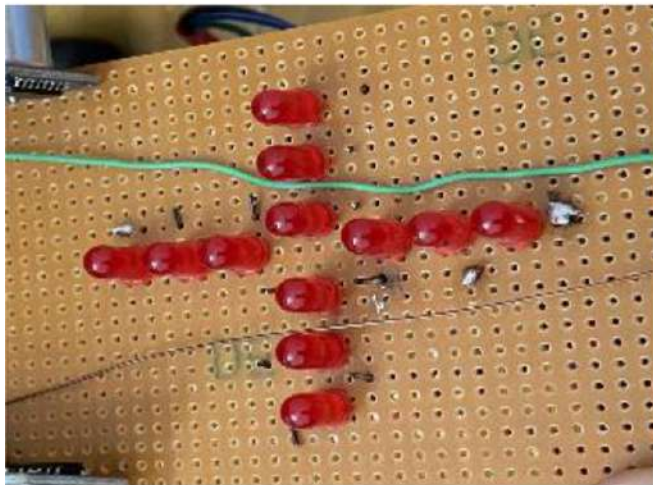

Figure 17 Power source

Circuit Description:

In this circuit we used four ultrasonic sonic sensors connected to Arduino's 8 analog pin with four trig and four echo pin of ultrasonic sensor. And other 8 pin of ultrasonic sonic sensor's are ground and power. The placement of sensors are in four sides of direction so that it can cover all side of vehicle. If any object detect by ultrasonic sensor's it will glow light. A display of light we build as display showing other vehicles around a vehicle. The negative pin of display are connected to all together to ground and other 12 pin of display are connected to Arduino for working as needed for ultrasonic sensors.

The GSM module connected two of Arduino's pin. GSM also powered separately. GSM module is said to be power hungry. GPS module to connected to two of Arduino's pin and two pin of power and ground powered by Arduino's pin. A sim card must inserted to GSM module which must have few balance to generate call. We used Robi sim card in our project. The accelerometer sensors are connected to 3 pin of Arduino's that's how connection are made. If we vibrate to accelerometer sensor's a change will be showing to display which will indicate that "Accident Detected" and "SMS sending" , "call generating".

Circuit may look complex cause there are many components and connecting wire used so it may look a little bit tight.

Program Code:

```
File Edit Sketch Tools Help
Acciden_Prevention_Final_Code
#include<LiquidCrystal.h>
LiquidCrystal lcd(42,40,52,50,48,46);
#define x A13
#define z A14
#define y A15

int xsample=0;
int ysample=0;
int zsample=0;

#define samples 10

#define minVal -100
#define MaxVal 100

const int trigPin1 =6;
const int echoPin1 = 7;
const int trigPin2 = 8;
const int echoPin2 = 9;
const int trigPin3 = 10;
const int echoPin3 = 11;
const int trigPin4 = 12;
const int echoPin4 = 13;

const int LED1 = A0;
const int LED2 = A1;
```

Figure 17 Code

```
pinMode(trigPin1 , OUTPUT);
pinMode(echoPin1 , INPUT);
pinMode(trigPin2 , OUTPUT);
pinMode(echoPin2 , INPUT);
pinMode(trigPin3 , OUTPUT);
pinMode(echoPin3 , INPUT);
pinMode(trigPin4 , OUTPUT);
pinMode(echoPin4 , INPUT);

pinMode(LED1 , OUTPUT);
pinMode(LED2 , OUTPUT);
pinMode(LED3 , OUTPUT);
pinMode(LED4 , OUTPUT);
pinMode(LED5 , OUTPUT);
pinMode(LED6 , OUTPUT);
pinMode(LED7 , OUTPUT);
pinMode(LED8 , OUTPUT);
pinMode(LED9 , OUTPUT);
pinMode(LED10 , OUTPUT);
pinMode(LED11 , OUTPUT);
pinMode(LED12 , OUTPUT);
```

Figure 18 Code

```
File Edit Sketch Tools Help
Acciden_Prevention_Final_Code
void setup()
{
    Serial.begin(9600);
    Serial1.begin(9600);

    lcd.begin(16,2);
    lcd.print("Accident Alert ");
    lcd.setCursor(0,1);
    lcd.print(" System ");
    delay(2000);
    lcd.clear();
    lcd.print("Initializing");
    lcd.setCursor(0,1);
    lcd.print("Please Wait...");
    delay(1000);

    lcd.setCursor(0,1);
    lcd.print("Acceleromiter");
    for(int i=0;i<samples;i++)
    {
        xsample+=analogRead(x);
        ysample+=analogRead(y);
        zsample+=analogRead(z);
    }
}

Acciden_Prevention_Final_Code
void loop()
{
    digitalWrite(trigPin1, LOW);
    delayMicroseconds(2);
    digitalWrite(trigPin1, HIGH);
    delayMicroseconds(10);
    digitalWrite(trigPin1, LOW);
    duration = pulseIn(echoPin1, HIGH);
    distance = duration/58.2;

    if ( distance <= 10 )
    {
        digitalWrite(LED1, HIGH);
    }
    else
    {
        digitalWrite(LED1, LOW);
    }
    if ( distance <= 20 )
    {
        digitalWrite(LED2, HIGH);
    }
    else
    {
        digitalWrite(LED2, LOW);
    }
}
```

Chapter: 05

Results

Performing all the required task to accomplish our desired output we have received a result.

LED light display

In the accident prevention side we check the LED display if something comes to its proximity the LED start glowing.

We fix the code as if something come within 30cm the last LED of one side will glow. something comes within 20cm the middle LED of will glow. something come within 30cm the closest LED will glow.

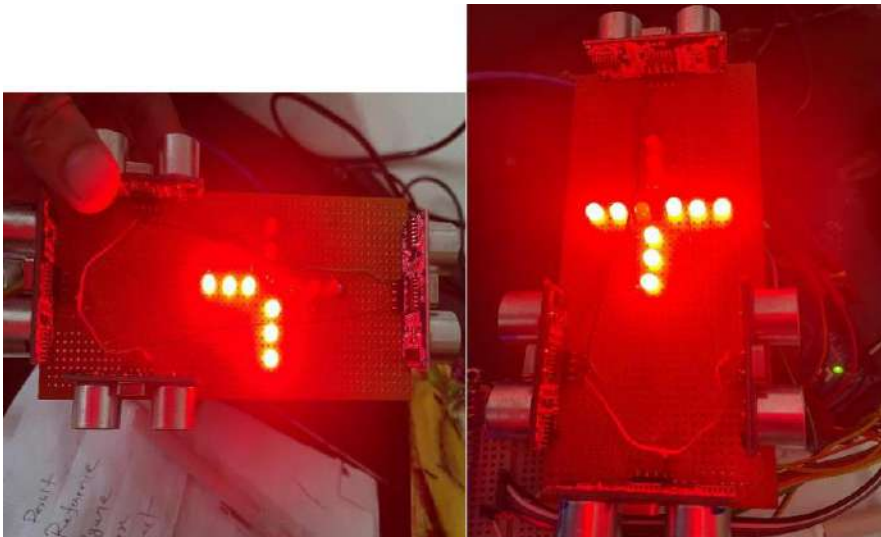

Figure 19 Output Display

In these two figures we can that one has three side block another is two side is blocked by obstacle that why the LED is blinking

Accident detection and Emergency Response:

Accident detected through accelerometer sensors if accelerometer changes its position from certain standard, it detects accident. It starts sending SMS to registered person in GSM circuit.

Here we did this job using an LCD display, this display shows the detection and emergency response. Below in the figure

+

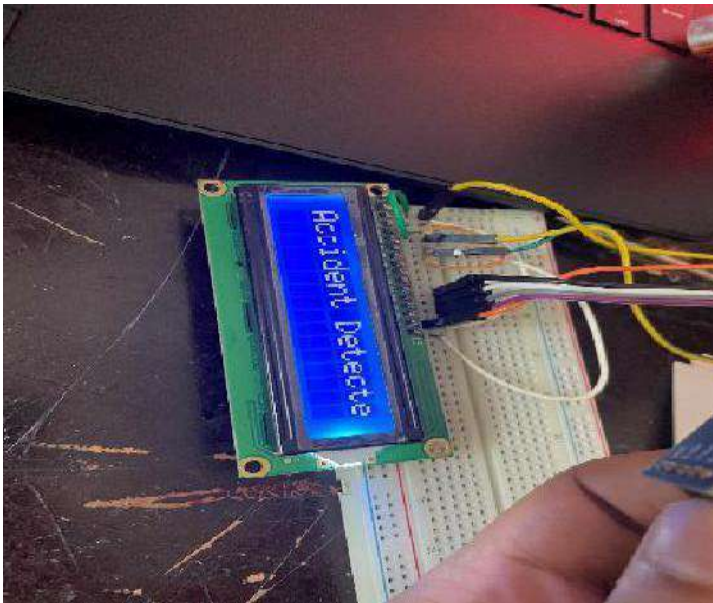

Figure 20 Output display 2

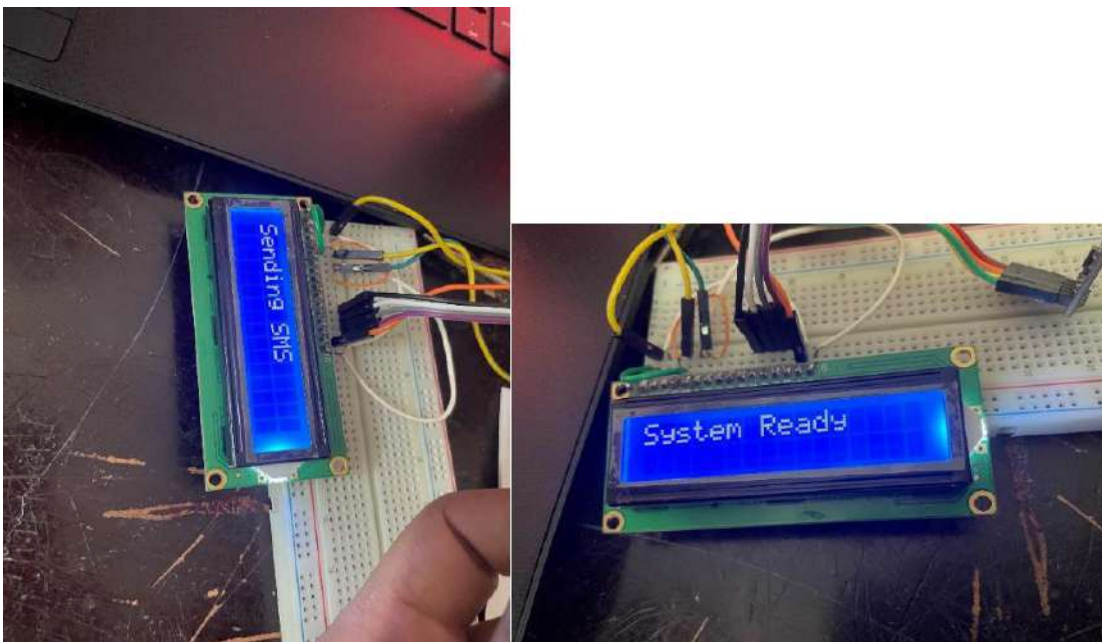

Figure 21 Output display 3

Chapter: 06

Conclusion

A lot of study is being done to support that technology, we have experienced lots of difficulties, especially creating the project, there has been many issues

Technology will never completely replace vigilant attention to detail and safe driving habits. But technology is a terrific complement since it can work to make accidents less likely. Different approaches put out by various writers assist us in effectively reserving and also reducing the necessity to ensure the safety of a vehicle. Users must be aware of the systems that randomly select different drivers for the Turkish Journal of Computer and Mathematics Education Vol.12 No.7 scheme, depending on the real-time prevention system. In order to give solutions for all threads, this article simplifies the context for all users while pioneering numerous algorithms. The intended system has the capacity to send accident information to the host Android device using an IOT-enabled application in the event of an accident.[45] With the ongoing development of science and technology in this century, a greater focus is placed on vehicle safety.

efficient, which makes installing it in a car simple. Unfortunately, if an accident does occur, the system recognizes it, and with the use of GPS, the precise location may be determined and relayed to an emergency unit using a GSM module. By alerting the rescue team in time, this helps to save many lives.

Overall, this system targets normal people and is simple to install in all kinds of vehicles. It is also quite economical. [46]

Finally we can conclude that lots of things involve to a single thing. Taking lots of papers to find out what we have been expected or what we deserved to solve the issue need to support the outcome we have desired.

Future scope of this work:

Everyday technology is being updated. New technology is replacing old technologies.

Accident prevention technology is possible to update on the basis of experiences gathered by this. There are numerous option to integrate

The system power can be powered up by engine heat or engine battery,

Every vehicle has an engine heating issue, this heating of the engine is kind of a waste for the vehicle, we can use this heat to produce power and can charge the battery. This can be used as a power source for technology we used in vehicles.

Technology aspects that help lower auto accidents may offer a way to address driver error. Automated systems that alert drivers of risky moves, such as drifting into another lane, and cutting-edge systems that begin steering or braking to avoid crashes may be able to mitigate some of the most prevalent driving habits that cause auto accidents. Here are nine instances of current technologies that help lessen automobile collisions.

1. Forward collision system
2. Lane departure technology
3. Blind spot detection
4. Automated emergency braking system
5. Backup Cameras
6. Cross-traffic Alert system
7. Rear crash imminent braking
8. Driver Monitoring system
9. Autonomous cruise control

When systems don't work as intended, technological advancements meant to increase safety might actually cause accidents. If this occurs, a City personal injury lawyer may be able to help with informed advice and capable representation. For a free case review, give us a call or fill this form.

Above mentioned technologies are the future scope of this type of technology advancement. Working on that is a great opportunity to enhance knowledge of transportation technology.

References

- [1] Jeong, Eunbi, and Cheol Oh. "Evaluating the effectiveness of active vehicle safety systems." *Accident Analysis & Prevention* 100 (2017): 85-96.
- [2] [Collision avoidance technology - Road Safety Technology - Research - NSW Centre for Road Safety](#)
- [3] [Road Accident: A Major Concern of Bangladesh \(cgs-bd.com\)](#)
- [4] [The Impact of Technology in Auto Industry - Importance of Technology](#)
- [5] [The Impact of Technology on the Automotive Industry - Arnia Software](#)
- [6] [The Future of Technology in the Automotive Industry | by Karl Utermohlen | Towards Data Science](#)
- [7] <https://marketbusinessnews.com/financial-glossary/wireless-technology/>
- [8] <https://www.encyclopedia.com/computing/news-wires-white-papers-and-books/wireless-technology>
- [9] <https://www.electronicshub.org/wp-content/uploads/2021/04/Elements-of-Wireless-Communication-System.jpg>
- [10] <https://worldwidesupply.net/blog/blogevolution-wireless-network-technology/#:~:text=1880%3A%20It%20all%20started%20with,radio%2C%20a%20framework%20was%20established>
- [11] https://www.tutorialspoint.com/wireless_communication/wireless_communication_overview.htm
- [13] <https://roboticsbiz.com/advantages-and-disadvantages-of-wireless-technologies/>
- [14] <https://www.geeksforgeeks.org/advantages-and-disadvantages-of-wireless-communication/>
- [15] <https://www.elprocus.com/types-of-wireless-communication-applications/#:~:text=Applications%20of%20wireless%20communication%20involve,various%20wireless%20communication%20Dbased%20projects.>
- [16] Malladi, R., & Agrawal, D. P. (2002). Current and future applications of mobile and wireless networks. *Communications of the ACM*, 45(10), 144-146.
- [17] Estrin, D., Govindan, R., Heidemann, J., & Kumar, S. (1999, August). Next century challenges: Scalable coordination in sensor networks. In *Proceedings of the 5th annual ACM/IEEE international conference on Mobile computing and networking* (pp. 263-270).
- [18] Kumar, S., & Moore, K. B. (2002). The evolution of global positioning system (GPS) technology. *Journal of science Education and Technology*, 11(1), 59-80.
- [19] Alshamsi, H., Kępuska, V. and Alshamsi, H., 2016. Real time vehicle tracking using arduino mega. *International Journal of Science and Technology*, 5(12), p.624.
- [20] <https://www.fierceelectronics.com/sensors/what-ultrasonic-sensor>
- [21] https://www.nicepng.com/downpng/u2w7y3a9t4u2i1a9_ultrasonic-distance-sensor-ultrasonic-sensor-png/
- [22] <https://www.orientdisplay.com/knowledge-base/lcd-basics/what-is-lcd-liquid-crystal-display/>
- [23] https://www.pngitem.com/download/hoiiTRx_display-lcd-datasheet-lcd-display-16x2-display-lcd/
- [24] https://www.energystar.gov/products/lighting_fans/light_bulbs/learn_about_led_bulbs
- [25] <https://pixabay.com/vectors/led-diode-light-emitting-26354/>
- [26] <https://www.fierceelectronics.com/sensors/what-accelerometer>
- [27] <https://www.pngegg.com/en/png-xahox/download>
- [28] <https://www.dpstele.com/rtu/cellular/gsm-module.php#:~:text=A%20GSM%20module%20is%20a,looks%20just%20like%20a%20phone.>
- [29] https://www.kindpng.com/downpng/hJwTbw_x_microchip-gsm-module-hd-png-download/
- [30] <https://www.rfwireless-world.com/Terminology/GPS-Sensor-function-and-working.html>
- [31] <https://www.electronicwings.com/storage/PlatformSection/TopicContent/113/description/pin%20description.jpg>
- [32] <https://www.liveabout.com/multimeter-what-is-a-multimeter-844780>
- [33] https://www.nicepng.com/downpng/u2t4y3t4o0w7e6o0_digital-meter-png-free-download-uni-t-ut139c/
- [34] Verma, Ayush, and Rohit Anand. "IoT-Based Smart System For Accident Detection And Prevention." *Mukt Shabd Journal*.
- [35] Vimalkumar, S., Hemalatha, P. and Kalaivani, J., 2018. A review on smart IOT car for accident prevention. *Asian J Appl Sci Technol*, 2(1), pp.287-292.
- [36] Palanisamy, R., Kumar, P.S., Kiran, M.P., Mahto, A., Irfan, M. and Bhowmick, M., 2020. Arduino based accident prevention and auto intimation system. *Indonesian Journal of Electrical Engineering and Computer Science*, 17(3), pp.1275-1280.
- [37] Bhatti, F., Shah, M.A., Maple, C. and Islam, S.U., 2019. A novel internet of things-enabled accident detection and reporting system for smart city environments. *Sensors*, 19(9), p.2071.
- [38] Meena, K., Amuthadevi, C. and Kumar, G.S., 2018. Internet of Things based accident prevention and detection system. *International Journal of Engineering & Technology*, [S. 1.], 7(2.4), pp.85-87.
- [39] Nanda, S., Joshi, H. and Khairnar, S., 2018, August. An IOT based smart system for accident prevention and detection. In *2018 Fourth International Conference on Computing Communication Control and Automation (ICCCUBEA)* (pp. 1-6). IEEE.
- [40] Yeo, C.J., Yu, J.H. and Kang, Y., 2020. Quantifying the effectiveness of IoT technologies for accident prevention. *Journal of Management in Engineering*, 36(5), p.04020054.
- [41] Mahapatra, R.P., Kumar, K.V., Khurana, G. and Mahajan, R., 2008, December. Ultra sonic sensor based blind spot accident prevention system. In *2008 international conference on advanced computer theory and engineering* (pp. 992-995). IEEE.

- [42] Nanda, S., Joshi, H. and Khairnar, S., 2018, August. An IOT based smart system for accident prevention and detection. In *2018 Fourth International Conference on Computing Communication Control and Automation (ICCUBEA)* (pp. 1-6). IEEE.
- [43] Jain, A., Thakrani, A., Mukhija, K., Anand, N. and Sharma, D., 2017. Arduino based ultrasonic radar system using Matlab. *International Journal for Research in Applied Science & Engineering Technology (IJRASET)*, 5(4), pp.215-218.
- [44] Uma, S. and Eswari, R., 2022. Accident prevention and safety assistance using IOT and machine learning. *Journal of Reliable Intelligent Environments*, 8(2), pp.79-103.
- [45] Reddy, P.D., 2021. A Novel Review on Modular Multilevel Converter for Induction Motor Drive Applications. *Turkish Journal of Computer and Mathematics Education (TURCOMAT)*, 12(10), pp.6303-6309.
- [46] Anand, S.J., 2021. Iot-based secure and energy efficient scheme for precision agriculture using blockchain and improved leach algorithm. *Turkish Journal of Computer and Mathematics Education (TURCOMAT)*, 12(10), pp.2466-2475.