

International Islamic University Chittagong
Department of Electrical and Electronic Engineering

Final Assignment Test Autumn-2020
 Course Code: CHEM-2301
 Time: 5 hours (Writing 4 hours 30 minutes + 30 minutes submission time)
 Section: 3F

Program: B.Sc. Engg. (EEE)
 Course Title: Chemistry
 Full Marks: 50 (Written 30 + Viva/Viva-Quiz-20)
 Set: E

[Answer each of the questions (1-5) from the followings; Figures in the right margin indicate full marks.]

- 1(a). Establish the relation between specific conductance and equivalent conductance. CO1 An 03
- 1(b). CO2 E 03

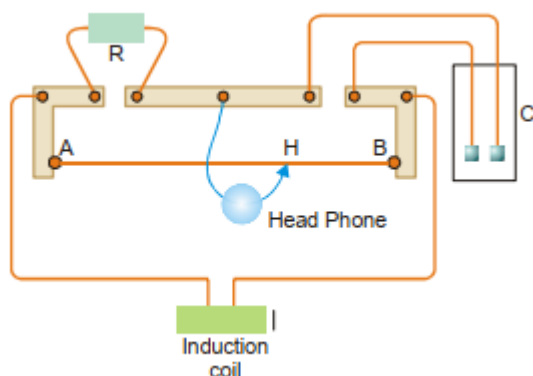

Figure: 01

A conductance cell containing a decinormal solution of a salt occupying a volume between two platinum electrodes 2.5 cm apart and 6.2 cm² area is connected with Wheatstone bridge. A resistance (R= summation of last two digit of your metric id) is unplugged when sliding contact is moved across a 10 m wire until the headphone is minimum at 7 m. Calculate equivalent conductance of the cell.

- 2(a). Discuss the Raoult's law for the determination of molecular mass of a non-volatile solute? CO1 U 03
- 2(b). Calculate the normality of a solution containing 28.0 g of Cu(OH)₂ dissolved in sufficient water to make 400 ml of solution? CO2 E 03
- 3(a). Explain by a suitable example, how equilibrium changes with temperature for exothermic and endothermic reaction. CO1 C 03
- 3(b). For the reaction $N_{2(g)} + 3H_{2(g)} \rightleftharpoons 2NH_{3(g)}$; $K_p = X.60 \times 10^{-x}$ at 400°C. Calculate ΔG° for the reaction.; [Given, X = summation of last two digit of your metric id, and ($R = 8.314J K^{-1} mol^{-1}$)] CO2 E 03
- 4(a). Derive an expression for the dependence of rate constant of a reaction with temperature and also show its graphical diagram. CO1 An 03
- 4(b). The rate constant of a second order reaction is $5.70 \times 10^{-(x+2)} dm^3 mol^{-1} sec^{-1}$ at 25°C and $1.64 \times 10^{-(x+4)} dm^3 mol^{-1} sec^{-1}$ at 40°C. Calculate the activation energy of the reaction. [Given, x= last one digit of your metric id and $R = 8.314 JK^{-1} mol^{-1}$]. CO2 E 03

5(a).	Distinguish between physical adsorption and chemical adsorption.	CO1	An	03
5(b).	Show diagrammatically the different types of adsorption isotherms obtained for adsorption of gases on solids.	CO2	Ap	03
6.	Viva: The time of viva will be declared in Google classroom.			20