

# Development of an Automatic Street Light Management System

By

Md. Jahir Uddin (ET111056)

Galib Anwar (ET111072)



BACHELOR OF SCIENCE IN ELECTRICAL & ELECTRONIC ENGINEERING

Department of Electrical & Electronic Engineering  
International Islamic University Chittagong

November, 2015

This page is blank

# **Development of an Automatic Street Light Management System**

By

Md. Jahir Uddin (ET111056)

Galib Anwar (ET111072)

A project submitted as partial fulfillment for the degree of  
**BACHELOR OF SCIENCE IN ELECTRICAL & ELECTRONIC ENGINEERING**

Department of Electrical & Electronic Engineering  
International Islamic University Chittagong

November, 2015

## Recommendation

This is to certify that **MD. Jahir Uddin** (ET111056) and **Galib Anwar** (ET111072), students of International Islamic University (IIUC) under the department of Electrical and Electronic Engineering, carried out the project titled “**Development of an Automatic Street Light Management System**”. To the best of knowledge, the matter embodied in the project had not been submitted to any other University for the award of the Degree.

---

Supervisor

Engr. S.M. Taslim Reza

Assistant Professor, Dept. of EEE

International Islamic University, Chittagong

## CANDIDATES DECLARATION

This project is titled as “**Development of an Automatic Street Light Management System**”, submitted by **MD. Jahir Uddin** (ET111056) and **Galib Anwar** (ET111072), Session: spring11-Autumn15, under the supervision of Engr. S.M. Taslim Reza has been accepted as satisfactory in partial fulfillment of the requirement for the degree of Bachelor of Science in Electrical & Electronic Engineering.

It is hereby declared that this project or any part of this is a result of our own work except for the excerpts that have been cited clearly in the references.

**1. Signature:** .....

Name: MD. Jahir Uddin

Matric ID: ET111056

**2. Signature:** .....

Name: Galib Anwar

Matric ID: ET111072

## **Acknowledgement**

First of all we want to thank Almighty Allah (SWT) for giving us opportunity to complete this entire project properly.

It gives us immense pleasure to express our deepest sense of gratitude and sincere thanks to our highly respected and esteemed guide Engr. S.M. Taslim Reza, Assistant Professor, dept. of EEE, IIUC, for his guidance throughout our dissertation work. It was real pleasure to work under his guidance.

We are also indebted to our parents and well-wishers who are taking lot of pains for progress in our life and for their sacrifices, blessing and constant prayers for our advancement.

We express our indebtedness of our friends for their help and valuable suggestions to complete this paper work and also for tolerating our mistakes and immaturity.

At last but not least, we are also thankful to those who have directly or indirectly helped us and encouraged us to complete this project. We feel sorry for not being able to express our appreciation to each of our well-wishers and ask forgiveness for our improper behavior with anyone who was intending to help us.

November, 2015

MD. Jahir Uddin  
&  
Galib Anwar

## **Abstract**

Nowadays, human life has become too much busy for manual work. It is rare to find time even to switching the lights wherever necessary. This project is basically organized for the developing modern society among us. For a developing country the most important content is to save its electrical energy. We tried here to develop such a street light system where we can reduce both cost and manual function. This project is developed in such a way that the percentage of manual work is almost demolished. Two types of sensors are used here. Light Dependent Sensor usually known as LDR is used to detect day & night, which will help to operate the system to run automatically and infrared sensors are used here for detecting the movement of the roads. Arduino Mega is used as the brain of this project which controls the full system. A GSM shield is used here to send alert messages in case there occurs any problem on the system or for safety issues. The programming language used in this prototype version is C Language. Finally the system is designed and implemented in its prototype version.

# Table of Contents

TITLE PAGE .....	iii
RECOMMENDATION .....	iv
CANDIDATES DECLARATION.....	v
ACKNOWLEDGEMENT.....	vi
ABSTRACT.....	vii
TABLE OF CONTENTS.....	viii
LIST OF FIGURES .....	x
LIST OF TABLE .....	xi
REFERENCES.....	32
APENDIX A .....	33
APENDIX B .....	35

## **CHAPTER 1: INTRODUCTION**

1.1 Introduction.....	1
1.2 Problem Statement .....	2
1.3 Objective .....	2
1.4 Project Outline .....	2

## **CHAPTER 2: LITERATURE REVIEW**

2.1 Introduction.....	4
2.2 Summary of Previous Work.....	4
2.3 Current Technology .....	5
2.4 Advantage of Street Lighting.....	5
2.5 Summary.....	6

## **CHAPTER 3: METHODOLOGY**

3.1 Introduction.....	7
3.2 Components Used .....	7

3.2.1	Obstacle Detector Sensors .....	7
3.2.1.1	Infrared Sensors .....	8
3.2.1.2	Ultrasonic Sensors .....	9
3.2.1.3	Motion detector Sensors .....	10
3.2.2	GSM Shield.....	11
3.2.3	Arduino Mega(2560) .....	12
3.2.4	Surface Mounted Device LED.....	14
3.2.5	LDR.....	15
3.2.6	Real Time Clock .....	15
3.3	Design & Implementation.....	17
3.3.1	Flow Chart .....	17
3.3.2	Circuit Design .....	19
3.3.2.1	Object Detecting Circuit .....	21
3.3.2.2	Light Intensity Control Circuit.....	21
3.3.2.3	GSM Notification Circuit .....	22
3.3.2.4	Real Time Clocking Circuit .....	23
3.4	Summary .....	24

## **CHAPTER 4: RESULT & CALCULATION**

4.1	Introduction.....	25
4.2	Result .....	26
4.3	Calculation .....	28
4.4	Summary .....	29

## **CHAPTER 5: CONCLUSION**

5.1	Introduction .....	30
5.2	Limitation.....	30
5.3	Future Development.....	31

## List of Figures

<b>Fig. 3.1</b> Basic principle of IR obstacle detector	8
<b>Fig. 3.2</b> IR sensor (fc51)	9
<b>Fig. 3.3</b> Ultrasonic obstacle detector	10
<b>Fig. 3.4</b> SIM900 GSM shield	11
<b>Fig. 3.5</b> Arduino Mega (2560)	12
<b>Fig. 3.6</b> Pin configuration Arduino 2560	14
<b>Fig. 3.7</b> Surface Mounted Device	15
<b>Fig. 3.8</b> Light Dependent Resistors	16
<b>Fig. 3.9</b> Pin Configuration of RTC (ds1307)	17
<b>Fig. 3.10</b> Flow Chart of the system	18
<b>Fig. 3.11</b> Circuit Diagram	19
<b>Fig. 3.12</b> Block Diagram of the Controller	20
<b>Fig. 3.13</b> Block Diagram of IR sensor	21
<b>Fig. 3.14</b> Intensity Control & Load check circuit	22
<b>Fig. 3.15</b> Real Time Clocking Circuit	23
<b>Fig. 4.1</b> Overall view of the project	25
<b>Fig. 4.2</b> (a) Empty roads of the project. (b) Notifying while the system started. (c) System is operational	26
<b>Fig. 4.3</b> (a) Residential lamps are off. (b) While passing a vehicle (c) LDR is operating the system (d) Receiving message while we disconnect any lamp	27

## **List of Table**

Table 4.1 Calculation of the project

29

# Chapter 1

## Introduction

### 1.1 Introduction

For building a modern civilization it must have to be equipped with modern facilities and technology. With modern technology there comes energy consumption. We can't create infinite power for our growing need, so we have to utilize what we have. In this contrary, we must reduce the energy consumption. People of this modern age came out from their traditional manual work and advanced themselves to the automatic section. In this way we can work faster, improve our product quality, less number of workers needed, in a word this is highly efficient.

In this project, we designed an automated street lighting system which not only be used as an energy efficient system but also be a cost effective and user friendly system. Our traditional street lights are mostly used with High Pressure Sodium (HPS) lights, Halogen lights and tube lights. All of these products are highly effective for their work but as well as they also consume most of the power from grid. According to study global grid based electricity consumption for lighting was about 2650 TW in 2005, which was an equivalent of 19% of total global electricity consumption. European office buildings dedicate about 50% of their electricity for lighting, whereas the share of electricity for lighting is around 20-30% in hospitals, 15% in factories, 10-15% in schools and 10% in residential buildings[1]. Traditional street light systems are manually controlled and a number of workers are need to be employed here. Organizing this huge amount of workers and operating them in right ways is very difficult and obviously costly. So, an automated street light system is much more preferable in our society.

There is a number of recent activity around the world about the automated street light system. Some of them are switched automatically, some are operated through GSM, and some are weather based. In our project I tried to add most of the feature in a cost effective way. Day by day the society is changing with new technology and services. More integrated circuits are coming day by day. We tried our best to equip the system with all the features that are minimal criteria for the system.

## **1.2 Problem Statement**

People now a days wants to do everything in automatic basis. This twenty first century thought us how to reduce our work and let the machine deal with the necessary work. In this regard while we focus on our local street lights we see how we waste our electrical energy there. Most of the time we see that streets lamps are switched on during morning. So, we decided to do the project on the street lamp on an automatic basis. While searching in the web we found lots of projects and papers regarding this subject. But we found many different limitations in almost all paper. It's obvious that there must be some limitation in every projects. But we believe our project covers most of the limitation from previous work. We are also successful to reduce the cost of our load in daily purpose.

## **1.3 Objective**

Our main goals of this project are as follows:

- Automatic switching of the street lights.
- Controlling light intensity according to real time clock
- Controlling light intensity after detection of human and vehicle.
- Notifying if fault occurs to the system through sms.

## **1.4 Project outline**

This project report is divided into five (5) chapters. A brief description of each chapter are given here.

Chapter 2: It discuss about the history and literature importance of this project. The history of the development of The Design of Street Light is discussed briefly. Why we need to have a street lighting system and why all the advancement are needed are described from different point of view.

Chapter 3: This is for the hardware description unit. All the major equipment that are required for the implementation and design of the project are discussed in this chapter. All the major equipment description and its operations are discussed clearly with relevant figure. In this chapter we also

discuss about how the project was done, its procedure and all other related works are given here. All the block diagram, flow charts, circuit design are noted here.

Chapter 4: This chapter stated about the results and output of the projects. It also have some note on the development of this project. The future scopes and improvements are described.

Chapter 5: The conclusion of the project report.

Finally the references are written in chronological order. At last the legends are used in the project report for stating a clear conceptions.

## Chapter 2

### Literature Review

#### 2.1 Introduction

There are some vital parts of the society that we could never argue about. As the technology is rising more accurate and advanced systems came into play. Like this we can't argue about the importance of street light in our society. If we go back around two hundred years we couldn't find any lamps over the streets. At the very beginning there was only manual system of the streets lights. Then along with the advancement of the technology it became automatic. But at present we are encouraged to think about the power consumption of the system. System needs to be operated automatic but it must be power consuming. The power generation is getting limited day by day. Sourced of renewal energy are always welcome. But most of the time they are not cost effective. So, it gives us the idea of using our limited power in such a way that we can effort it. Using the limited power in our daily work and make ensure that rest of the people can also attain that.

Keeping that idea in mind we tried to implement a system where it will be automatic in operation and power consuming.

#### 2.2 Summary of Previous Work

Uses of street lights were first seen in 18<sup>th</sup> century. It came by the improvement of Francois-Pierre Ami Argand, a brilliant scientist and inventor. He was a Swiss scientist who was invented the Argand lamp, a great improvement on the traditional oil lamp. These types of lamps were first used in street lights [2]. There was also some improvements in this field in different criteria. Like developing of Oil lamp, Gas light, Carcel lamp during 19<sup>th</sup> century. But the most important invention of this century is electrical lamps. Also there came different white lamps and colorful one too. But after the invention of electric lamps it became most popular around the world. After that demonstration of neon light, fluorescent lamp, sodium vapor lamps came into play.

The first street to be lit by an incandescent light bulb was in Mosley Street, Newcastle upon Tyne. The street was lit by Joseph Swan's incandescent lamp on 3 February 1879 [3]. Consequently, Newcastle was one of the first cities in the world to be fully lit up by lighting [4]. The first in the United States, and second overall, was the Public Square road system in Cleveland, Ohio, on April 29, 1879. Wabash, Indiana holds the title of being the third electrically lit city in the world, which took place on February 2, 1880 [5].

Incandescent lamps were primarily used for street lighting until the advent of high-intensity discharge lamps. They were often operated at high-voltage series circuits. Series circuits were popular since the higher voltage in these circuits produced more light per watt consumed. Furthermore, before the invention of photoelectric controls, a single switch or clock could control all the lights in an entire district. To avoid having the entire system go dark if a single lamp burned out, each street lamp was equipped with a device that ensured that the circuit would remain intact.

### **2.3 Current Technology**

Today, street lighting commonly uses high-intensity discharge lamps, often HPS high pressure sodium lamps [6]. Such lamps provide the greatest amount of photopic illumination for the least consumption of electricity. However, white light sources have been shown to double driver peripheral vision and improve driver brake reaction time by at least 25%; to enable pedestrians to better detect pavement trip hazards [7] and to facilitate visual appraisals of other people associated with interpersonal judgments. Studies comparing metal halide and high-pressure sodium lamps have shown that at equal photopic light levels, a street scene illuminated at night by a metal halide lighting system was reliably seen as brighter and safer than the same scene illuminated by a high pressure sodium system.[8] High pressure sodium lights are most popular till now. These types of lights are highly suitable for highway. But in residential area where pedestrian, bicycle and vehicles or animals that doesn't carry headlights we cannot use sodium lights. A study shows that human eye can bear a minimum amount of light intensity. This range of intensity on human eye is measured by the S/P ratio. When S/P ration is higher than it's referred as a desirable intensity. Important thing is that for sodium light it needs to be reduced by 25% for the S/P ratio test [9].

New street lighting technologies, such as induction lights, emit a white light that provides high levels of scotopic lumens allowing street lights with lower wattages and lower photopic lumens to replace existing street lights. UK is currently undergoing a project to see 6000 of its street lights converted to LED and will be closely followed by Hastings in early 2014. Photovoltaic-powered luminous lights are gaining wider acceptance.

## **2.4 Advantages of Street Lighting**

Major advantages of street lightings are given bellow

- Preventing from accidents and increase in safety issue
- Studies have shown that darkness results in a large number of crashes and fatalities, especially those involving pedestrians, Street lighting has been found to reduce pedestrian crashes by approximately 50%.
- lighted intersections and highway interchanges tend to have fewer crashes than unlighted intersections and interchanges
- Towns, cities, and villages use the unique locations provided by lampposts to hang decorative or commemorative banners.

## **2.5 Summary**

Despite all the efforts of previous works that have been done this system will be more cost effective and user friendly. We cannot convert our usual lamps of the streets in a day. It's a long process. What we can do is to make the system as low power consuming as possible. To do so we think our project is well suited. This is the part of the motivation of this project.

## **Chapter 3**

### **Methodology**

#### **3.1 Introduction**

This chapter describes the importance and necessity of the equipment that we used in the project. Only the vital elements of this project are described here. A project cannot run with some simple resistor or capacitor. There are a lot more than that. They are as follows.

#### **3.2 Components Used**

The main components that we used in our project are given serially bellow:

- Infrared Obstacle Detector Sensor
- Global System for Mobile Communications (GSM) shield
- Arduino Board Mega
- Surface Mounted Device (SMD) light
- Light Dependent Resistor (LDR)
- Real Time Clock (RTC)

The components that we used here are described below.

##### **3.2.1 Obstacle detector Sensors**

Obstacle detectors are used in this project to ensure if there is any vehicle in the roads. It helps the controller to decide when to dim the light and when to switch off the light. As we know, we don't have much traffic after 10PM-12PM. At that time full intensity of street lights are totally a wastage of energy. Though we see in local areas that after 12PM some City Corporation lights are switched off. But they can't detect any creature in the streets. So, accident might happen or theft, robbery can occur. So, to remove all these types of problems we used obstacle detectors on the roads.

Now obstacle detectors can be of different types. We studied some potential sensors to use as obstacle detector. Three types of obstacle detectors are widely used for this purpose. They are briefly described below.

### 3.2.1.1 Infrared Sensor

Infrared technology addresses a wide variety of wireless applications. The main areas are sensing and remote controls. In the electromagnetic spectrum, the infrared portion is divided into three regions: near infrared region, mid infrared region and far infrared region. The wavelengths of these regions and their applications are shown below.

- Near infrared region — 700 nm to 1400 nm — IR sensors, fiber optic
- Mid infrared region — 1400 nm to 3000 nm — Heat sensing
- Far infrared region — 3000 nm to 1 mm — Thermal imaging

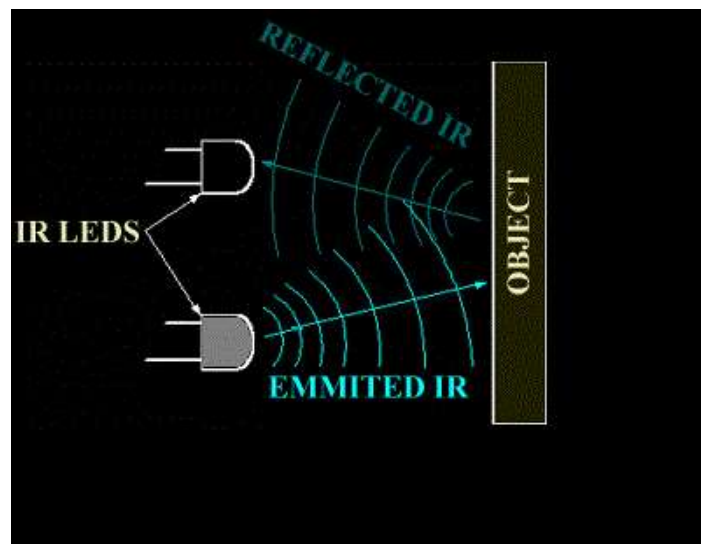

Fig. 3.1: Basic Principle of IR Obstacle Detector

Pin configuration of IR (fc51) is given here:

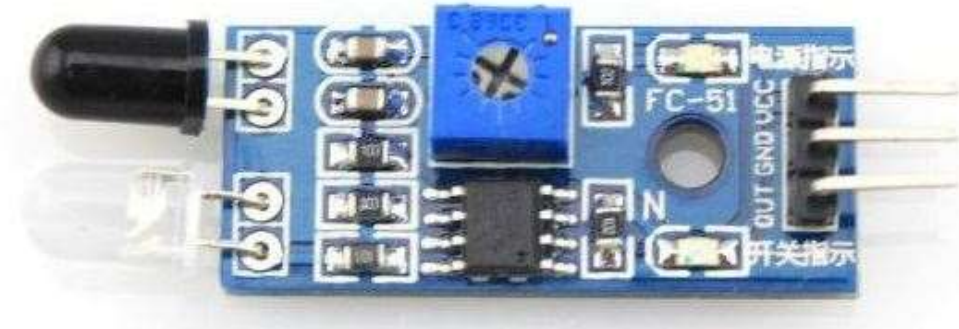

Fig. 3.2: IR Sensor (fc51)

Some important features of IR sensor are:

- Detection distance: 2 ~ 30cm
- Detection angle: 35°
- VCC is around 3.3V-5V

An infrared sensor emits and/or detects infrared radiation to sense its surroundings. The basic concept of an Infrared Sensor which is used as Obstacle detector is to transmit an infrared signal, this infrared signal bounces from the surface of an object and the signal is received at the infrared receiver. That means there will be a infrared transmitter and there will be a infrared receiver. IR transmitter will transmit the signal and if it gets any obstacle in front it will bounce that signal back to the sensor where IR receiver will receive the signal. Next IR receiver will activate the controller to do whatever necessary.

### 3.2.1.2 Ultrasonic Sensor

Ultrasonic sound sensors are used to detect if there is any moving element near any subject or thing. They are mainly used for the blind people to check if there is any obstacle near him. That same principle could be used in our project of Automatic Street Light.

There are two ports as usual one transmits the signal and other receive it. It continuously transmit signals in its running time.

This types of sensors can detect any motion from 4-5meter away. It sends out pulses of ultrasonic waves and measures the reflection off a moving object. When a moving element come close to the sensor it gives randomly higher signal to the controller. And when the element moves away from the sensor it gives lower signal [10].

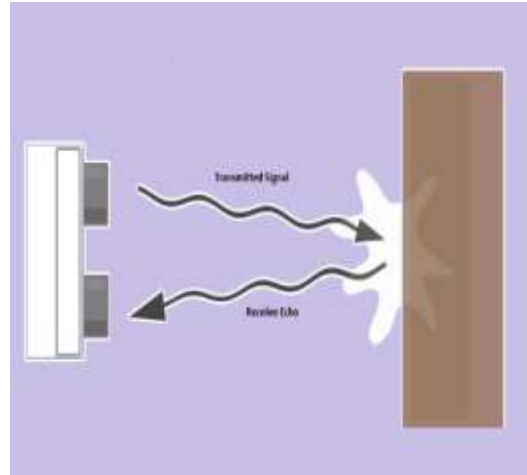

Fig. 3.3: Ultrasonic Obstacle detector

In this way the detector can sense if there is any moving subject near him. An active motion detector should try to eliminate as much noise or false data as possible. To do so, it often analyzes the Doppler Effect frequency variations in echoes, as well as amplitude changes. This type of detector is fairly complex and often includes a programmable microcontroller.

In terms of our project the sensor will detect if there is any vehicle on the road. As the vehicle come close to the sensor it will send message to the controller that a moving element is coming so the lights need to be switched on. And when the vehicle will cross the range of the sensor the controller will do what next it needs to do.

### 3.2.1.3 Motion Detector Sensor

An electronic motion detector contains an optical, microwave, or acoustic sensor, and in many cases a transmitter for illumination. However, a passive sensor only senses a signal emitted by the moving object itself. Changes in the optical, microwave, or acoustic field in the device's proximity are interpreted by the electronics based on one of the technologies listed below. Most inexpensive motion detectors can detect up to distances of at least 15 feet (5 meters). Specialized systems are more expensive but have much longer ranges. Motion detectors have found wide use in domestic and commercial applications. One common application is activation of automatic door openers in businesses and public buildings.

From above all those types of sensors, some are cheap and flexible for work. Again some have complexity among them. Regarding all these factors it seems to us that infrared sensors are very helpful and they have a good range of working area then other. More over motion sensors, vibrating

sensors, ultrasonic sensor can pick up any sounds, noise, or any types of vibrating element in the process. Where infrared will pick up only the transmitted signal into the receiver.

### 3.2.2 G.S.M Shield

The SIM900 GSM/GPRS Shield provides you a way to use the GSM cell phone network to receive data from a remote location. The shield allows you to achieve this via any of the three methods:

- Short Message Service
- Audio
- GPRS Service

A GSM shield is like a cell which can be operated and compatible around the globe. Its unique feature gives the best uses of security protocols. It can transfer data through SMS between two machine located in two different places. Remote control appliance can be easily controlled by GSM shield. Using its GPRS system it can be used as vehicle detector or controller.



Fig. 3.4: SIM900 GSM shield

Here are some unique feature of the SIM900 are given bellow:

- Power supply +5V
- Quad-Band 900/ 1800 / 1900 MHz would work on GSM networks in all countries.
- Short Message Service – so it can send small amounts of data over the network.
- Speaker and Headphone jacks for sending DTMF signals or play recordings.
- SIM Card holder and GSM Antenna
- Low power consumption - 1.5mA(during sleep mode)

### 3.2.3 Arduino Mega(2560)

Arduino is an open-source prototyping platform based on easy-to-use hardware and software. Arduino boards are able to read inputs - light on a sensor, a finger on a button, or a Twitter message and turn it into an output- activating a motor, turning on an LED, publishing something online. All this is defined by a set of instructions programmed through the Arduino Software.

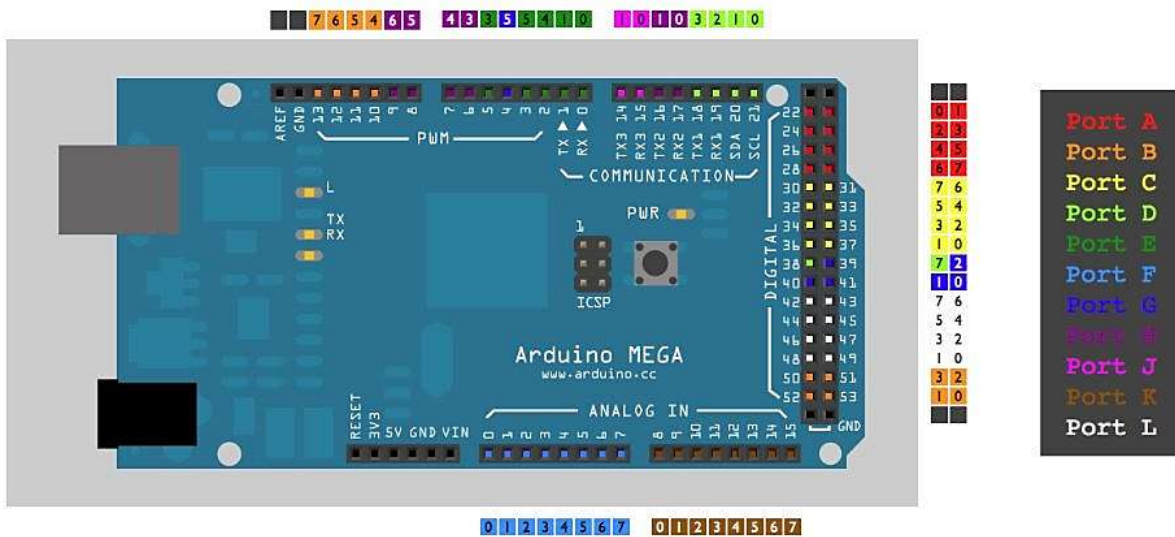

Fig. 3.5: Arduino Mega (2560)

Which is a build in function of Arduino. The Arduino Mega (2560) is a microcontroller board based on the ATmega2560.

There are many other microcontrollers and microcontroller platforms available for physical computing. Parallax Basic Stamp, Netmedia's BX-24, Phidgets, MIT's Handyboard, and many others offer similar functionality. All of these tools take the messy details of microcontroller programming and wrap it up in an easy-to-use package. The boards are built around the AVR microcontroller as the base. Software libraries to run on the board are written and made available for free. Using Arduino is much better then microcontroller because microcontroller doesn't have its own enrich libraries.

Arduino also simplifies the process of working with microcontrollers, but it offers some advantage for teachers, students, and interested amateurs over other systems:

- Inexpensive
- Cross-platform
- Open source and extensible software
- Open source and extensible hardware
- Simple, clear programming environment

The pin configuration of Arduino Mega (2560) is given here:

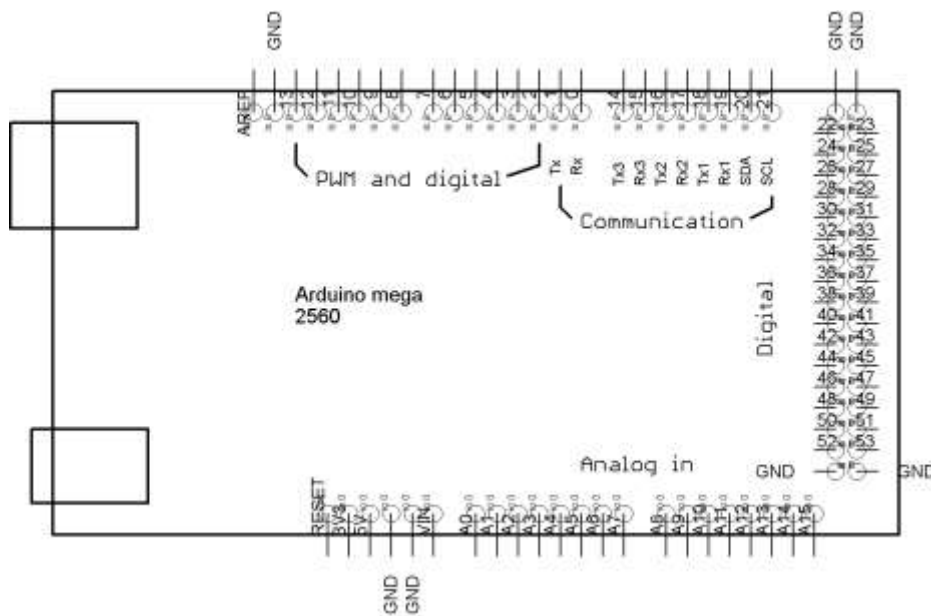

Fig. 3.6: Pin Configuration Arduino 2560

### 3.1.4 Surface Mounted Device LED

Surface Mounted Device LED is commonly known as “SMD LED”. An SMD LED Module is a type of LED module that uses Surface-mount technology (SMT) to mount LED chips are printed on PCB circuit boards. It is a self-contained Surface-Mount LED device designed either to function on its own or to plug into a compatible unit [11].



Fig. 3.7: Surface Mounted Device

There are some special feature which makes SMD as a useful device and also it makes itself a better device then normal LED.

The features that cannot be ignored in this device are given bellow:

- Creates very less heat during running condition.
- Requires low voltage and current to run.
- Consumes low power than normal LED but gives high brightness.
- Size of a SMD is smaller than LED.
- It requires (2-3.6)V and (0.02-0.03)A
- Under normal current and voltage condition life span of SMD can reach to 100,000hr.
- SMD consists of three light emitting source.

All these features make the product much more effective than normal LED. It's a cost effective way to design our street light management project. On the other hand in many comparative steps local LED's are not up to the upgraded mark as SMD. Considering all these features and benefits we used SMD in our project.

### 3.1.5 LDR

LDR stands for light dependent resistor. It is a passive electronic component, basically a resistor which has a resistance that varies depending of the light intensity. A photo resistor is made of a high resistance semiconductor that absorbs photons and based on the quantity and frequency of the absorbed photons the semiconductor material give bound electrons enough energy to jump into the conduction band. The resulting free electrons conduct electricity resulting in lowering resistance of the photo resistor. The number of electrons is dependent of the photons frequency. LDRs or Light Dependent Resistors are very useful especially in light/dark sensor circuits. Normally the resistance of an LDR is very high, sometimes as high as 1000 000 ohms, but when they are illuminated with light resistance drops dramatically. The resistance is very high in darkness, almost high as 1M $\Omega$  but when there is light that falls on the LDR, the resistance is falling down to a few K $\Omega$ .

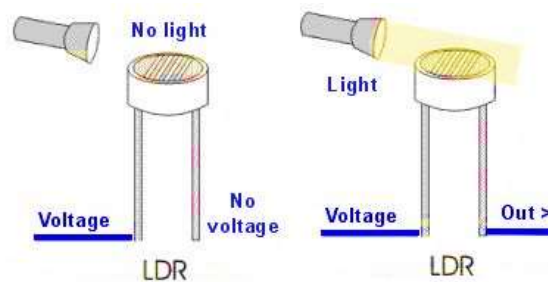

Fig. 3.8: Light Dependent Resistors

LDR were used in this project for switching purpose. When the sunlight comes it turn OFF the system and when the night falls it switches ON the system. It does its work automatically. So, no one needs to go and switch the lights on the roads. Less human resource means less cost.

### 3.1.6 Real Time Clock

A real-time clock (RTC) is a computer clock that keeps track of the current time. Most often in the form of an integrated circuit. Although the term often refers to the devices in personal computers, servers and embedded systems, RTCs are present in almost any electronic device which needs to keep accurate time. The term is used to avoid confusion with ordinary hardware clocks which are only signals that govern digital electronics, and do not count time in human units. RTC should not be confused with real-time computing [12].

Some projects such as data-logger, Scheduling On/Off, clocking etc. will need to have consistent timekeeping that doesn't reset when the power is down or the program needs to reset. For these purposes we need to use RTC in our project. The pin diagram of the real time clocking device is given here.

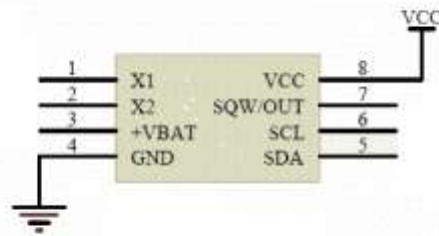

Fig. 3.9: Pin Configuration of RTC (ds1307)

Our project can be done without RTC but main purpose of this is to reduce complexity in time fixing method. As it can run by itself along with other devices [13].

The purpose of using this device are:

- Low power consumption.
- Frees the main system for time-critical tasks.
- Sometimes more accurate than other methods.
- Can operate under different power source.

RTCs often have an alternate source of power, so they can continue to keep time while the primary source of power is off or unavailable. This alternate source of power is normally a lithium battery in older systems, but some newer systems use a super capacitor, because they are rechargeable and can be soldered. The alternate power source can also supply power to battery backed RAM

## **3.2 Design & Implementation**

Here in this part we discussed about how we designed the circuit and implementation of it to fulfill our prototype version of Automatic Street Light Management System. In a brief discussion we could say Arduino is used as the brain of the project instead of a direct microcontroller, LDR is used to detect sunlight, Infrared Sensors are used to detect vehicle on the streets and RTC is used for clocking the system so that we could manage a well-furnished design for the streets.

Street lights of our project is divided into three types. They are as follows:

- Highway Roads
- Residential Roads
- By-Lane Roads

In all this sections the functions of street lights are almost identical. So, while describing the circuits here we meant roads in general for all the sections.

### **3.2.1 Flow Chart**

The system is designed by Arduino Mega2560 and developed on of C++ basic language. The Mega2560 executes program as bellow flow chart.

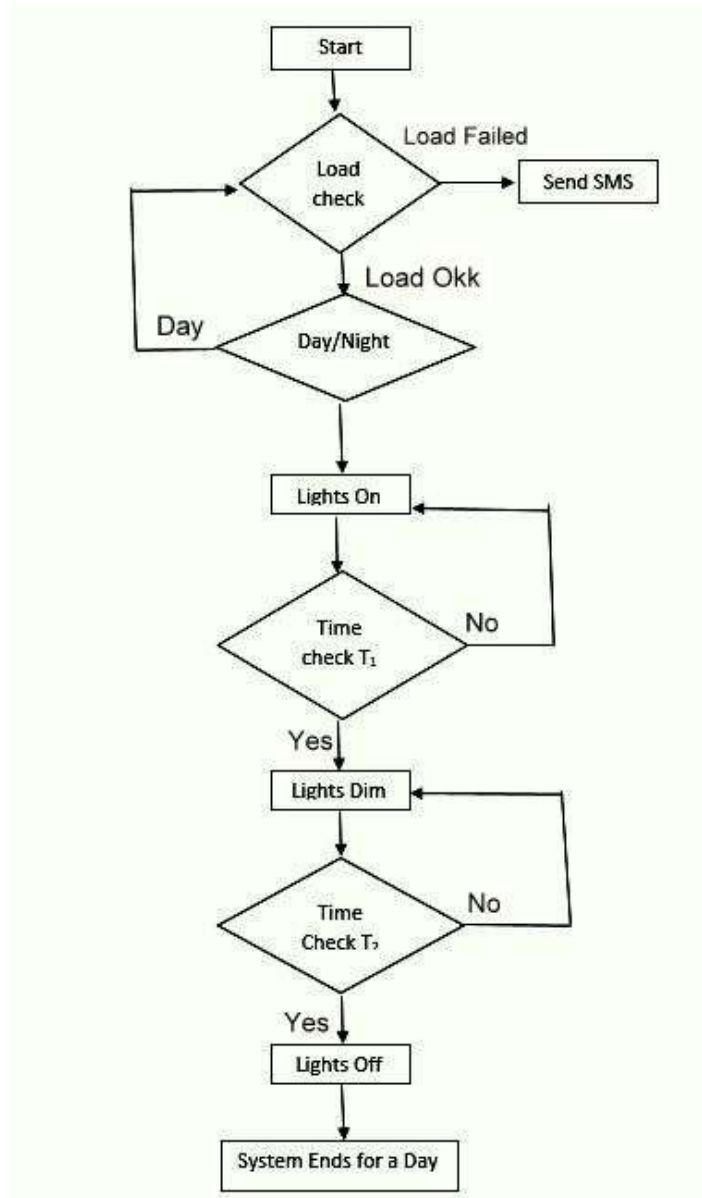

Fig. 3.10: Flow chart of the system

As the system starts first of all it checks for the load. If there is any failure to the load due to overheated, open connection or burglary happens it will send a message to the concern authority for help. If the load is ok then it will execute to its next decision. Next step is to check for day light presence. When LDR detects it is morning then the system will remain off. If it detect night then the system will run for the period of  $T_1$  time (described in general form as we have multiple streets for a locality). As the time comes it dims the intensity of the light. And again it searches for the

time  $T_2$ . As it comes it turns off the light. If any passersby come across the road after this time then the sensor will operate and it will turn on the light for five min's.

### 3.2.2 Circuit Design

The whole project is divided into smaller circuits. In this section we will discuss briefly about all the circuitry function. For describing the circuit easily we sectionalized the circuit in different categories. But first we attach our main circuit diagram here. As the diagram shows that it is very integrated, so it will be easier to understand the circuit in simpler view.

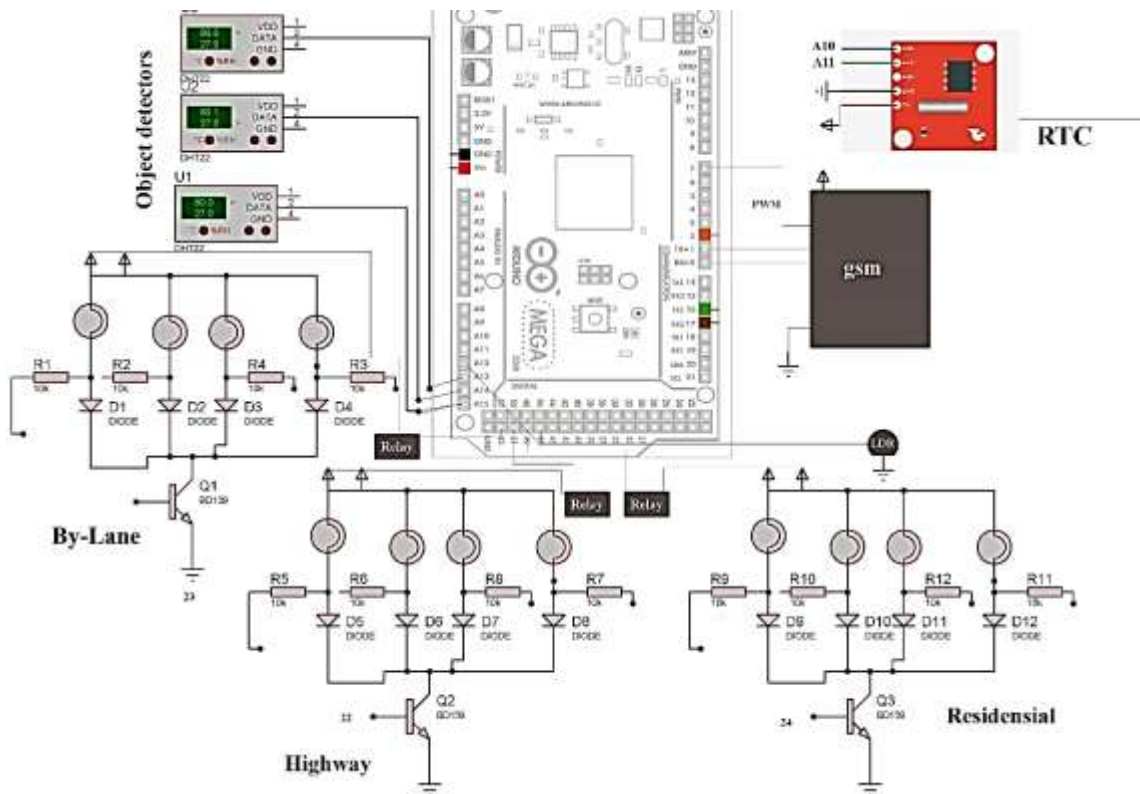

Fig. 3.11: Circuit Diagram of the system

Here, we enclosed the block diagram of the controller.

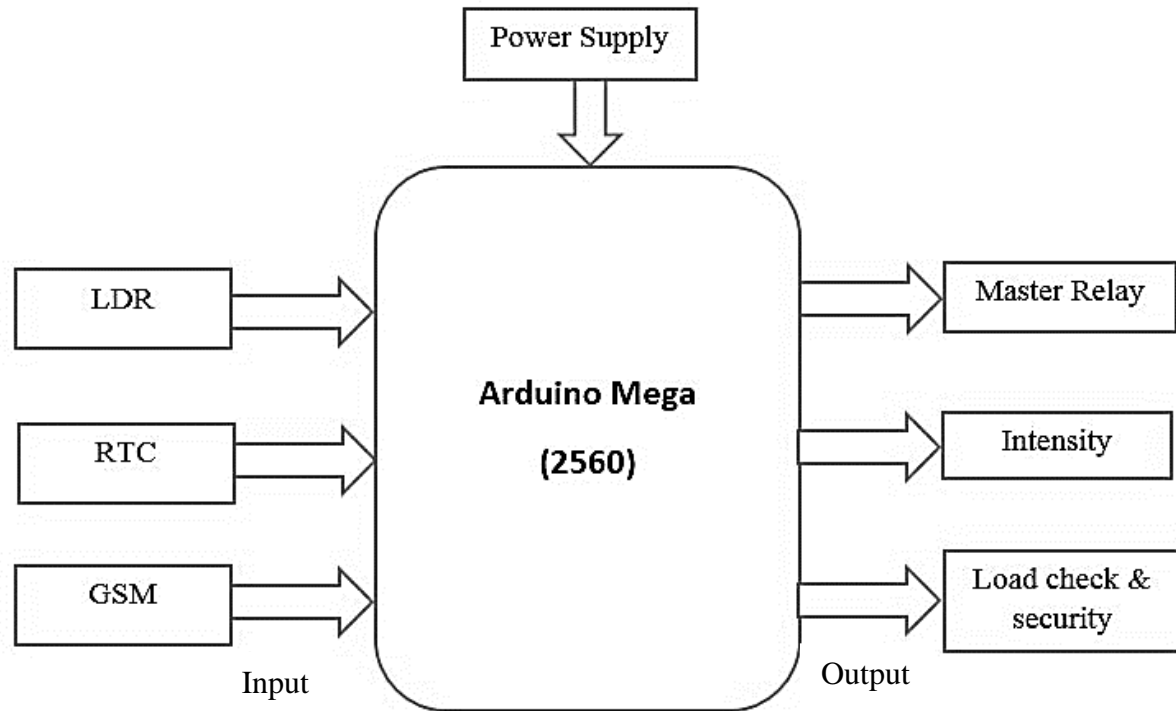

Fig.3.12: Block Diagram of the controller

Circuits were sectionalized into the following ways:

- Object Detecting Circuit
- Light Intensity Control Circuit
- GSM Notification Circuit
- Real Time Clocking Circuit

### 3.2.2.1 Object Detecting Circuit

The infrared sensor module is adaptable to the environment. It consists of a pair of infrared transmitter and receiver tube. When the transmitter sends the infrared rays it spread out to find any obstacles.

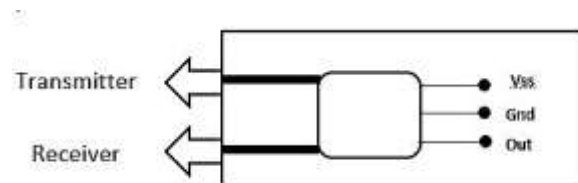

Fig. 3.13: Block Diagram of IR sensor

If it detects any obstacle then the receiver tube receives the signal and pass the signal to the controller. The controller then take the necessary steps as it is instructed. The IR module has three (3) pin attached with it. One is connected with 5V DC as VCC. This voltage is to operate the module. Another pin is the GND pin referred as the ground pin of the module. The last one is its output pin. This pin is connected with the input of the controller, as the controller receives the input from the sensor. It covers the range of at least 2~30cm area. Moreover it has a range of 35° detection angle.

### 3.2.2.2 Light Intensity Control Circuit

It's the basics of every device that when there is a full voltage applied to the device it operates with its full capacity and when it gets low voltage it runs in low its capacity. Same basic we applied to the lamps here. We used SMD lights for our project. As we applied 7V for them they run with

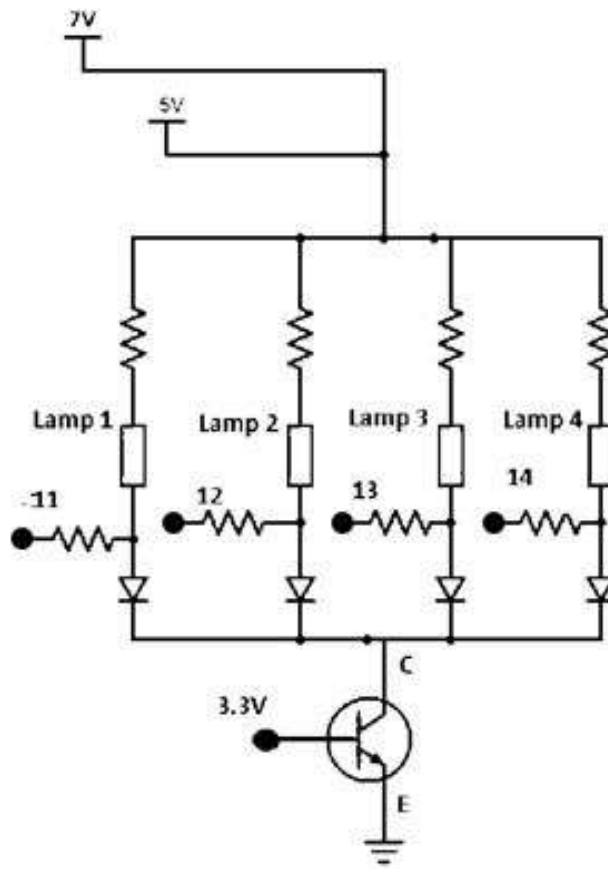

Fig. 3.14: Intensity control & load check circuit

full capacity. While controlling the intensity we programmed the controller so that it reduces its voltage during the specific period of time. Here, in our project, we proposed to dim the streets of Residential and By-Lane areas. So when the time comes the controller switches the line from 7V to 5V. The minimum requirement of a SMD is 3.60V. It gives full intensity when it gets 7V from the line. As soon as it gets the 5V line it dims the intensity. The figure 12 above shows the circuitry connections.

### 3.2.2.3 GSM Notification Circuit

It is obvious that a lamp can be over heated or can be damaged by any means. As it appears in our traditional system, it took more than a week to supply a new lamp. This happens not because of shortage problem but because of lack of resources. The authority doesn't even know that some

lamps of certain streets got failed. So, to overcome this problem we used a GSM shield. It will instantly send message when a light is off or not working. As we see the fig above we will see there are some external ports besides each lamp. Those are directly connected with GSM. GSM runs a program of possibility of failure in every five (5) min. As we see in the fig: 12 that, port 11, 12, 13, 14 of the circuit came out and they will be connected with the controller. An npn transistor is connected with the circuit at the bottom. This is because when the GSM check for any lamp failure it turn off the main line for a millisecond. Which is too fast for us to see. At that time the transistor uses its voltage approximately of 3.3 volt and keep the system running. If any lamp is failed to run it sends a message to the concern authority about the incident.

#### **3.2.2.4 Real Time Clocking Circuit**

An arduino board is obviously more capable than a microcontroller. But as it controls various functions it cannot run the time schedule on its own. So, we used a Real Time Clocking device for the purpose. Our street lights needs to control its intensity with the time. So, an RTC helps us to connect with the real timing. As soon as the clock touches 10PM it dims all the lights of the residential and by-lane streets. After 12PM all the streets of by-lane and residential gets totally off. But it doesn't mean when a passers-by passes through the lane the lamp will be off. There will be sensors activated after 12AM, which will run till the morning and if any passersby walks around the lamp will be ON again.

The fig shows the circuitry connection of the RTC:

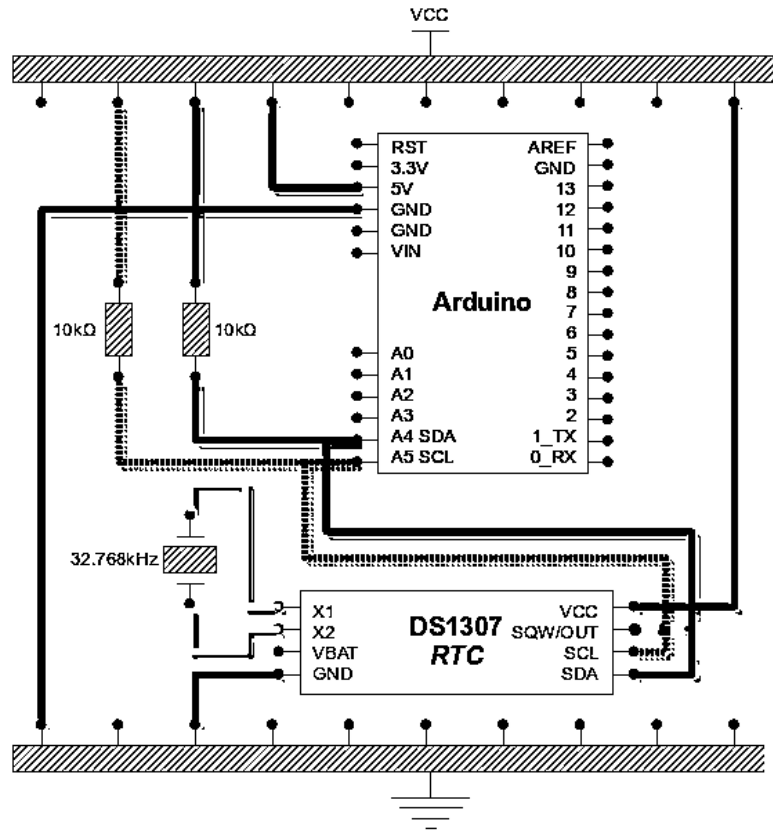

Fig. 3.15: Real time clocking circuit

The ground mood and the Vcc mood are specified with a single line in the diagram. There might be slightly change on the connection panel but all the workings are same.

### 3.3 Summary

At the end of this chapter we learned about the components that we used in the project in a brief way. We also included here about the circuitry problems and solutions. A flow chart is given for better understand of the project. All circuitry sections are described as much as possible.

## **Chapter: 4**

### **Design & Implementation**

Here in this part we discussed about how we designed the circuit and implementation of it to fulfill our prototype version of Automatic Street Light Management System. In a brief discussion we could say Arduino is used as the brain of the project instead of a direct microcontroller, LDR is used to detect sunlight, Infrared Sensors are used to detect vehicle on the streets and RTC is used for clocking the system so that we could manage a well-furnished design for the streets.

Street lights of our project is divided into three types. They are as follows

- Highway Roads
- Residential Roads
- By-Lane Roads

In all this sections the functions of street lights are almost identical. So, while describing the circuits here we meant roads in general for all the sections.

#### **4.1 Circuits Design**

The whole project is divided into smaller circuits. In this section we will discuss briefly about all the circuitry function. First of all the circuits were sectionalized into the following ways

- Object Detecting Circuit
- Light Intensity Control Circuit
- Timing Circuit
- GSM Notification Circuit

### 4.1.1 Object Detecting Circuit

The infrared sensor module is adaptable to the environment. It consists of a pair of infrared transmitter and receiver tube. When the transmitter sends the infrared rays it spread out to find any obstacles.

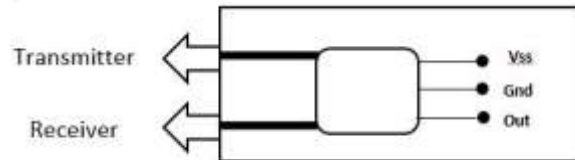

If it detects any obstacle then the receiver tube receives the signal and pass the signal to the controller. The controller then take the necessary steps as it is instructed. The IR module has three (3) pin attached with it. One is connected with 5V DC as VCC. This voltage is to operate the module. Another pin is the GND pin referred as the ground pin of the module. The last one is its output pin. This pin is connected with the input of the controller, as the controller receives the input from the sensor. It covers the range of at least 2~30cm area. Moreover it has a range of 35° detection angle.

### 4.1.2 Light Intensity Control Circuit

It's the basics of every device that when there is full voltage applied the device it operates with its full capacity. Same basic we applied to the lamps here. We used SMD lights for our project. As we applied 7V for them they run with full capacity. While controlling the intensity we programmed the controller so that it reduces its voltage during the specific period of time. Here, in our project, we proposed to dim the streets of Residential and By-Lane areas. So when the time comes the controller switches the line from 7V to 5V. The minimum requirement of a SMD is 3.60V. It gives full intensity when it gets 7V from the line. As soon as it gets the 5V line it dims the intensity.

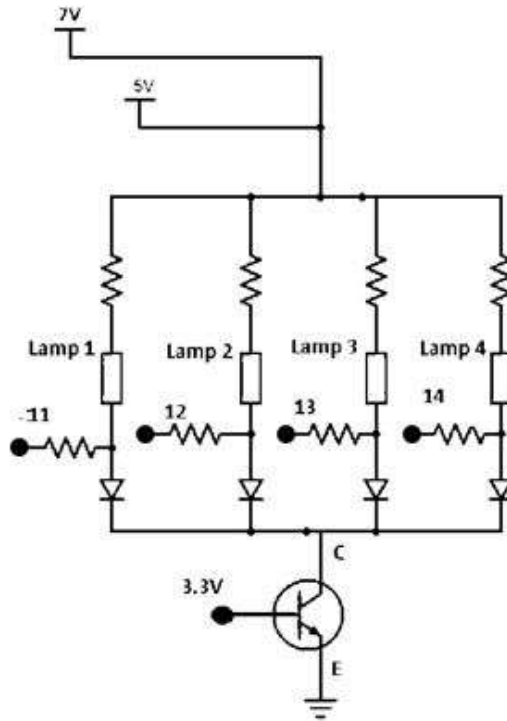

### 4.1.3 GSM Notification Circuit

It is obvious that a lamp can be over heated or can be damaged by any means. As it appears in our traditional system, it took more than a week to supply a new lamp. This happens not because of shortage problem but because of lack of resources. The authority doesn't even know that some lamps of certain streets got failed. So, to overcome this problem we used a GSM shield. It will instantly send message when a light is off or not working. As we see the fig above we will see there are some external ports besides each lamp. Those are directly connected with GSM. GSM runs a program of possibility of failure in every five (5) min. As we see in the fig:... that port 11, 12, 13, 14 of the circuit came out and they will be connected with the controller. An npn transistor is connected with the circuit at the bottom. This is because when the GSM check for any lamp failure it turn off the main line for a millisecond. Which is too fast for us to see. At that time the transistor uses its voltage approximately of 3.3 volt and keep the system running. If any lamp is failed to run it sends a message to the concern authority about the incident.

#### 4.1.4 Timing Circuit

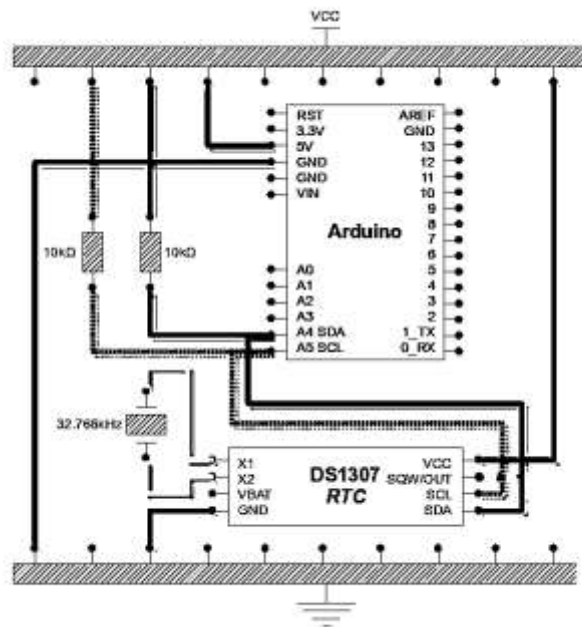

An arduino board is obviously more capable than a microcontroller. But as it controls various functions it cannot run the time schedule on its own. So, we used a Real Time Clocking for the purpose. Our street lights needs to operate its intensity with time. So, an RTC helps us to connect with the real timing. As soon as the clock touches 10PM it dims all the lights of the residential and by-lane streets. After 12PM all the streets of by-lane and residential gets totally off. But there are sensors, which will run all the time and if any passersby walks around the lamp will be ON again. The fig above shows the circuitry connection of the RTC.

include prevention of accidents and increase in safety.[36Rea, M. S., J. D. Bullough, C. R. Fay, J. A. Brons, J. Van Derlofske and E. T. Donnell. 2009. Review of the Safety Benefits and Other Effects of Roadway Lighting [report to the National Cooperative Highway Research Program]. Washington, DC: Transportation Research

**Board.] Studies have shown that darkness results in a large number of crashes and fatalities, especially those involving pedestrians; pedestrian fatalities are 3 to 6.75 times more likely in the dark than in daylight.[37Sullivan, J.M., and Flannigan, M.J. (1999) Assessing the Potential Benefit of Adaptive Headlighting Using Crash Databases, Report No. UMTRI-99-21. University of Michigan Transportation Research Institute.] Street lighting has been found to reduce pedestrian crashes by approximately 50%.[38Schwab, R.N., Walton, N.E., Mounce, J.M., and Rosenbaum, M.J. (1982) Synthesis of Safety Research Related to Traffic Control and Roadway Elements-Volume 2, Chapter 12: Highway Lighting. Report No. FHWA-TS-82-233. Federal Highway Administration.][40 Commission Internationale de l'Éclairage. (1992) Road Lighting as an Accident Countermeasure. CIE No. 93. Vienna, Austria: Commission Internationale de l'Éclairage.] Furthermore,.[41 Box, P.C. (1970) Relationship Between Illumination and Freeway Accidents. IERI Project 85-67 Illuminating Research Institute, New York April, pp. 1-83.] Towns, cities, and villages use the unique locations provided by lampposts to hang decorative or commemorative banners.**

## **1.1 Methodology**

Here we used Light Depending Resistors (LDR) for switching purpose. It detects intensity of light as in morning or night. An LDR automatically operates when the night rises. Again we used infrared sensors to detect movement in the roads. It helps the controller to change the intensity of

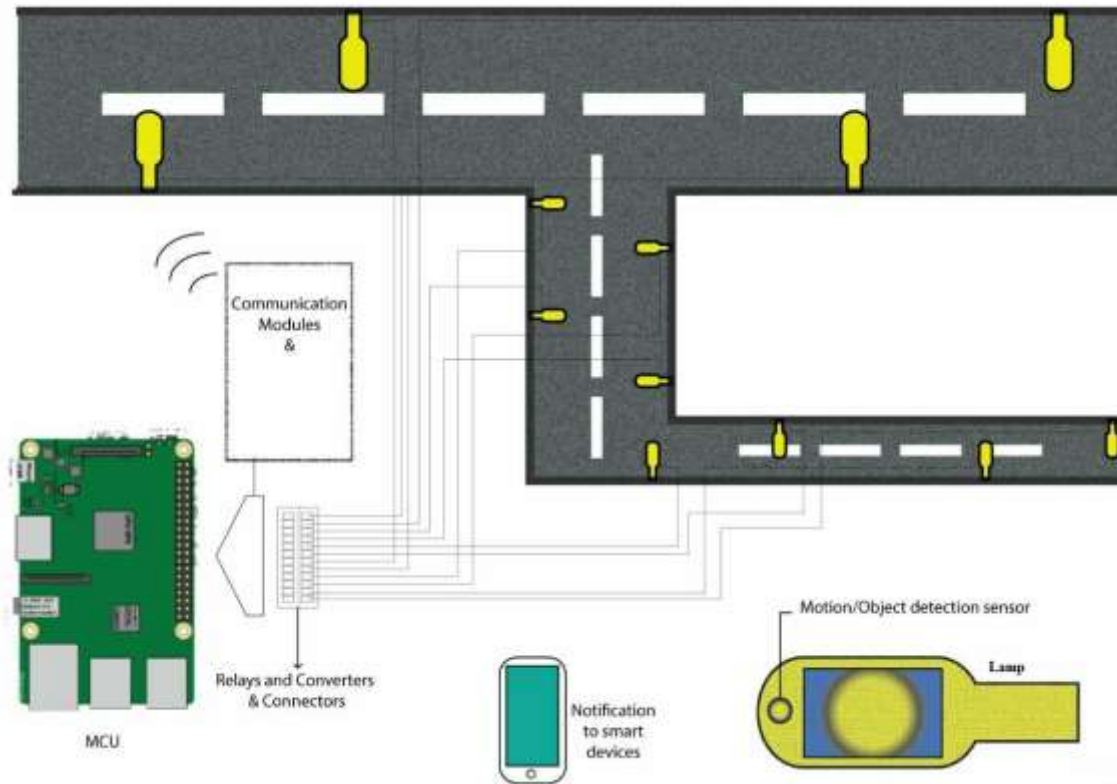

the light. Light intensity needs to be controlled because after a due time the number of vehicles on

Figure 1: Prototype of the project

the roads are very few. So, full intensity of light is just a wastage of the power.

Another most important thing is that failure of lights are very disturbing. Specially after 12AM people in the roads are very few. So, if there happens any failure or theft on the street lights then it will not be a safety zone for local people. To remove this types of hamper we used a Global System for Mobile Communications (GSM) shield. This a modem which is connected with the system and sends mobile notification if there any types of failure or theft happens.

## Chapter 4

### Result & Discussion

#### 4.1 Introduction

Every successful project has its own result and calculation. Without proper result no project could count as a standard one. If all the condition of the project were run successfully then there has to be some result. Here we enclosed some pics that says that we are successful in completing our project. All the pictures that are given bellow are only taken after the completion of the project.

The picture bellow fig: 4.1 is the total outlook of the project.

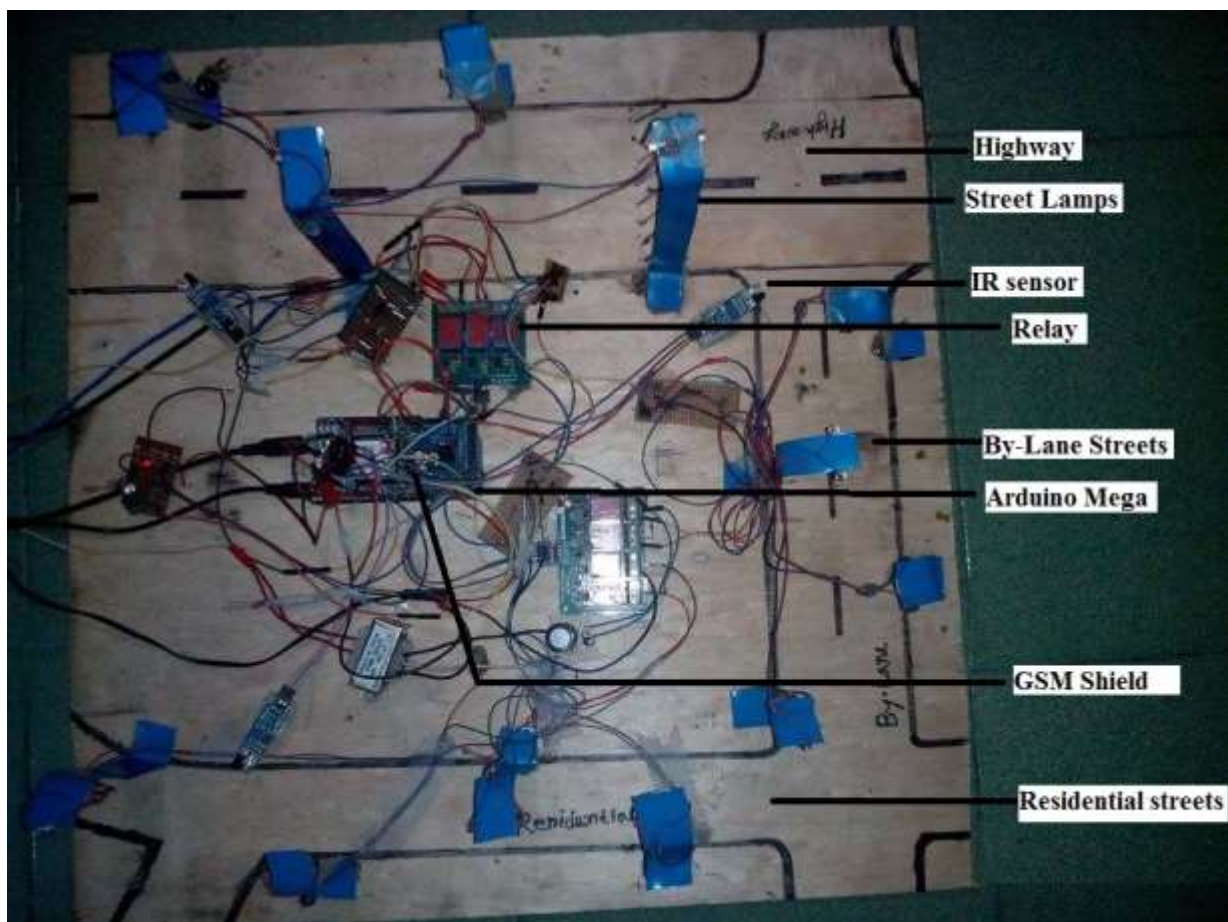

Fig. 4.1: Overview of the project

## 4.2 Result

Here are some pictures given to show the output of the project.



(a)

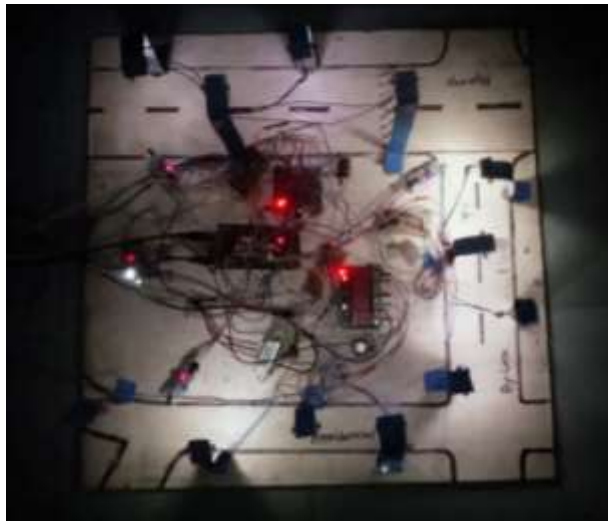

(c)

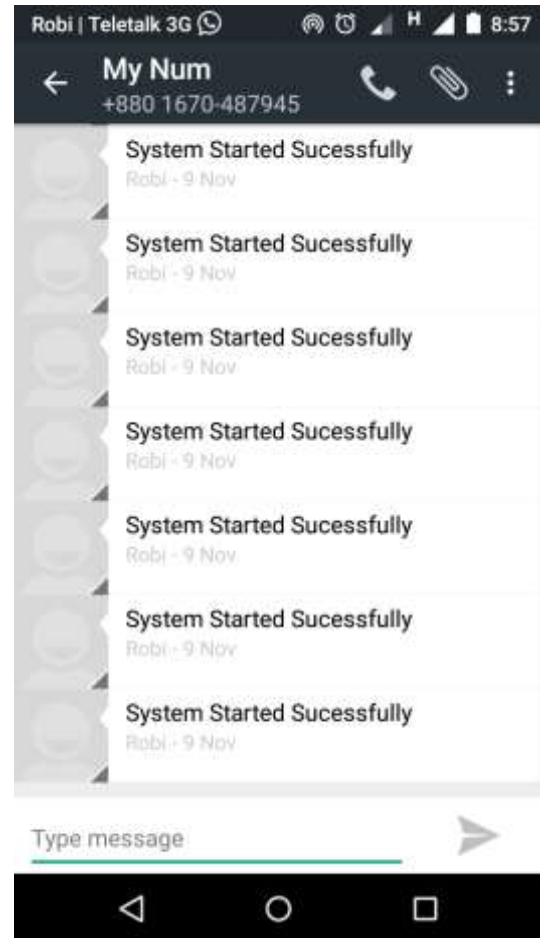

(b)

Fig.4.2: (a) Empty roads of the project. (b) Notifying while the system started. (c) System is operational

Here fig.4.2 (a) shows us the identification of each roads. We designed a wood to mark the streets. On the fig. (b) we see a bundle of message. This message were intercepted while the system is going to start. When the GSM shield says system is operational then the controller starts to operate the system. Which we see in fig. (c).

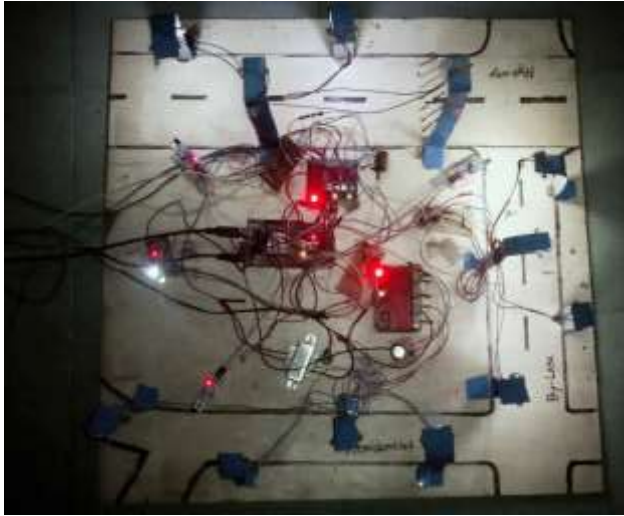

(a)

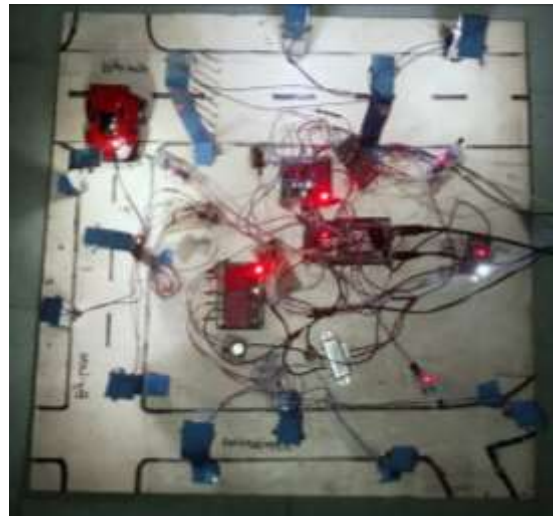

(b)

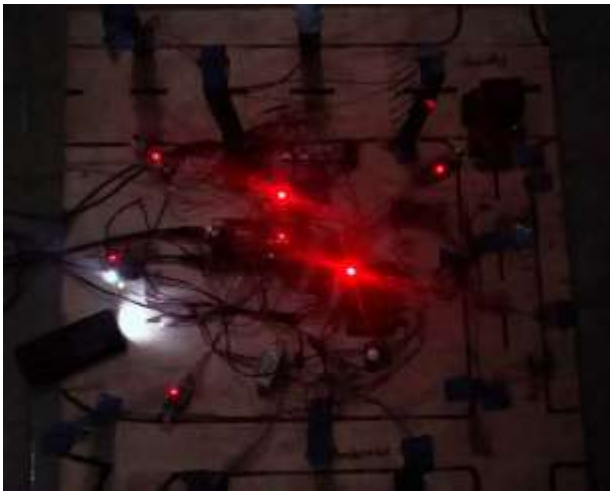

(c)

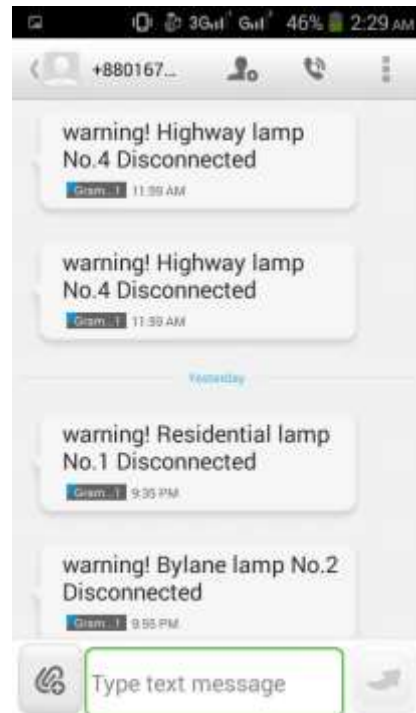

(d)

Fig.4.3: (a) Residential lamps are off. (b) While passing a vehicle (c) LDR is operating the system (d) Receiving message while we disconnect any lamp.

We designed our system in such a schematic way that it deals with real time clock. When it is 12PM all the residential lamps will be off and rest of the lamps will be dimmed. In fig. (a) we see the residential lamps are off. Now while the streets are dimmed or off if any vehicle or human

passes by then lamps will be on for few minutes giving the opportunity to cross the streets. Which we showed in fig. (b). Though our system is schedule based but if the sun showed up early then usual time the LDR takes the major and shut down the system. Fig. (c) shows when LDR gets any light it shut down the system instant. Now lamps might get robbed or may be failed or may be some fault can occur there. In that case the GSM shield come into the play and sends message indicating in which streets lamps are disconnected. That shows in fig. (d).

### 4.3 Calculation

Suppose, we have an area where 60 lamps were used. Among them 30 lamps were for highway purpose, 15 lamps for residential purpose and 15 lamps for by-lane purpose.

We also assume that,

- Highway lamps are 1000W
- Residential lamps are 700W
- By-lane lamps are 500W

Now when the intensity of the lamps were dimmed then we calculated the result by the following approximation value

- Highway lamps are 750W
- Residential lamps are 550W
- By-lane lamps are 350W

Again according to the Bangladesh Power Development Board charge of per KWh of street light is 3.25tk [14].

For a general purpose we can say we need street lamps from 6PM-5AM that is for 11hr.

Name	General Calculation		Project Calculation	
	Power Consume(KWh)	Cost (tk)	Power Consume(KWh)	Cost (tk)
High Way	330	1072.5	312	1013.7
Residential	115.5	375.375	106.5	346.13
By-lane	82.5	268.125	75.75	246.19
Total	528	1716	494.25	1606

Table 4. 1: Calculation of the project

#### 4.4 Summary

In this chapter we showed the results and output of our project in details. We also showed that our project can minimize a total of hundred and ten taka (110 tk) per day. Though we calculated this under some approximation, but it can be assured that this system will be better than our traditional one.

## **Chapter 5**

### **Conclusion**

#### **5.1 INTRODUCTION**

Our traditional street light is operated manually all over the country. The present system is like, the street lights will be switched on in the evening before the sun sets and they are switched off on the next day morning after there is sufficient light on the roads. Street lighting is a vital element in creating navigable, safe and successful cities. However, with 20% of the world's energy consumed by artificial lighting, perhaps it is time to rethink our approach for lighting purpose. That is what we tried to do in our project. Consuming energy and also human activities as much as possible was our main goal. We showed through our project that, street light management system can be digitalized with proper direction and it will help us to reduce the percentage of the use of the electricity in street lighting. Again as an automatic system it reduces the number of working people. Which is defiantly a plus point for the concern authority. Initial cost of the project may be high but for the long run purpose it will be a well suited system.

#### **5.2 Limitation of the Project**

While working in the project we found many limitations here. Some of our important limitations are described here:

- We cannot achieve full power from the line. For this lamps that are first in the row gets full voltage and glow brighter but the least one doesn't.
- As the system is controlled by program, we realize that when we put all the features at a time it interface with each other's conditions. Resulting a huge disturbance in the project.
- While demonstrating we couldn't use RTC, as it counts only real time. So we programmed the system for max five minutes here.

### **5.3 Future Development**

We believe our proposed street light management system will be the best cost effective system for a developing country. But on the contrary, considering the economic states of a country there might have some developments in this sector. Such as:

- Implementing solar panel for the system.
- Using facial recognition as sensor for more accurate purpose.
- Finding a suitable solution for low power consuming lamps.

## Reference

1. Prof. K.Y.Rajput, Gargeyee Khatav, Monica Pujari, "Intelligent Street Lighting System Using Gsm" International Journal of Engineering Science Invention Volume 2 Issue 3 March. 2013
2. Wolfe, John J. Brandy, Balloons, & Lamps: Ami Argand, 1750-1803; Southern Illinois University Press, 1999
3. Sir Joseph Wilson Swan. Home.frognet.net. Retrieved 16 October 2010.
4. "Electric lighting" <http://www.ncl.ac.uk>. Retrieved 2014-06-03
5. Cleveland, Public Art (brochure). Positively Cleveland. 2008. Retrieved 2009-05-18
6. Bullough, John, MS Rea & Y. Akashi, "Several views of metal halide and high pressure sodium lighting for outdoor applications" Lighting Research and Technology 2009. Retrieved November,14
7. Fotios S, Cheal C. "Using obstacle detection to identify appropriate illuminances for lighting in residential roads". Lighting Research & Technology, 2013
8. Rea, M. S.; J. D. Bullough & Y. Akashi. "Several views of metal halide and high pressure sodium lighting for outdoor applications" Lighting Research and Technology 2009
9. Fotios SA & Cheal C, "Predicting Lamp Spectrum Effects At Mesopic Levels". Part 1: Spatial Brightness, Lighting Research & Technology, 2011
10. "Technology comparison of Motion Sensors", <http://www.ecosirius.com/technology.html>
11. "LED Guideline, Panasonic group"; [https://www.vossloh-schwabe.com /uploads/tx\\_sbd downloader/LED\\_Grundlagen\\_2014\\_EN\\_01.pdf](https://www.vossloh-schwabe.com/uploads/tx_sbd downloader/LED_Grundlagen_2014_EN_01.pdf)
12. Application Note 10337 (PDF), ST Microelectronics, 2004, p. 2
13. "Enabling Timekeeping Function and Prolonging Battery Life in Low Power Systems", NXP Semiconductors, 2011
14. "Electricity Tariff"; <http://www.bpdb.gov.bd/download/tariff.pdf>, September 1, 1999.

## Appendix A

### Calculation

#### Calculating for General System:

$$\begin{aligned}\text{Highway} &= (30 \times 1000) \text{ W} \\ &= (30000/1000) \text{ KW} \\ &= 30 \text{ KW} * 11\text{Hr} \\ &= (330 \times 3.25) \text{ tk per KWh} \\ &= 1072.5 \text{ tk} \\ \text{Residential} &= (15 \times 700)/1000 \text{ KW} \\ &= (10.5 \times 11) \text{ KWh} \\ &= (115.5 \times 3.25) \text{ tk per KWh} \\ &= 375.375 \text{ tk} \\ \text{By-lane} &= (15 \times 500)/1000 \text{ KW} \\ &= (1.5 \times 11) \text{ KWh} \\ &= (82.5 \times 3.25) \text{ tk per KWh} \\ &= 268.125 \text{ tk} \\ \text{Total cost} &= 1072.5 + 375.375 + 24.375 \\ &= 1716\end{aligned}$$

#### Calculating for Proposed System:

No of lamps in each area and there power will be same in this calculation. It will help us understand that this project reduces cost than usual one.

#### Highway:

Lamp will be dimmed after 12AM. As the sensor will awake the light if any passersby or vehicle goes through the street, so we took an approximate of 3hr extra for full intensity.

$$\begin{aligned}\text{Full intensity} &= (30 \times 1000/1000) \times (6+3) \text{ KWh} \\ &= (270 \times 3.25)\end{aligned}$$

$$=877.5 \text{ tk}$$

$$\text{Low intensity} = (30*750/1000)*(2) \text{ KWh}$$

$$= (42*3.25)$$

$$=136.2 \text{ tk}$$

Residential:

Lamp will be dimmed after 10AM. As the sensor will awake the light if any passersby or vehicle goes through the street, so we took an approximate of 3hr extra for full intensity.

$$\text{Full intensity} = (15*700/1000)*(4+3) \text{ KWh}$$

$$= (73.5*3.25)$$

$$= 238.875 \text{ tk}$$

$$\text{Low intensity} = (15*550/1000)*(4) \text{ KWh}$$

$$= (33*3.25)$$

$$=107.25 \text{ tk}$$

By-Lane:

Lamp will be dimmed after 11AM. As the sensor will awake the light if any passersby or vehicle goes through the street, so we took an approximate of 3hr extra for full intensity.

$$\text{Full intensity} = (15*500/1000)*(5+3) \text{ KWh}$$

$$= (60*3.25)$$

$$= 195 \text{ tk}$$

$$\text{Low intensity} = (15*350/1000)*(3) \text{ KWh}$$

$$= (15.75*3.25)$$

$$= 51.1875 \text{ tk}$$

Therefore,

$$\text{Total cost} = 877.5+146.25+238.875+107.25+195+51.1875$$

$$= 1606$$

$$\text{Difference} = (1716-1606) \text{ tk}$$

$$=110 \text{ tk}$$

## Appendix B

### Program Code

```
/*=====
  shedule light intesity control part
===== */

#include <Time.h>
#include <TimeAlarms.h>

//===== for sms

#include "SIM900.h"
#include <SoftwareSerial.h>
//#include "inetGSM.h"
#include "sms.h"
MSGSMS sms;

int numdata;
boolean started=false;
char smsbuffer[160];
char n[20];

//=====
int ldrReading;//analog pin reading from ldr
```

```

const int highwayHigh = 53;
const int highwayLow = 52;
const int bylineHigh = 51;
const int bylineLow = 50;
const int resHigh = 49;
const int resLow = 48;
void setup()
{
  Serial.begin(9600);

  //===== for sms

  Serial.println("GSM Shield testing.");
  //Start configuration of shield with baudrate.
  //For http uses is raccomanded to use 4800 or slower.
  if (gsm.begin(2400)) {
    Serial.println("\nstatus=READY");
    started=true;
  }
  else Serial.println("\nstatus=IDLE");

  if(started) {
    if (sms.SendSMS("01830310839", "System Started Sucessfully"))
    Serial.println("\n gsm started");
  }
}

```

```

//=====

setTime(17,59,0,10,10,15); // set time to Saturday 8:59:00PM 10 10 2015
// create the shedule
Alarm.alarmRepeat(18,0,0, Evening); // evening every day
Alarm.alarmRepeat(18,01,0,TenPM); // 10PM every day
Alarm.alarmRepeat(18,02,0,ElevenPM); //11PM everyday
Alarm.alarmRepeat(18,03,0,MidNight); //12:01 Everyday
Alarm.alarmRepeat(18,05,0,Morning); //05:00am Everyday

Alarm.timerRepeat(15, lightcheck); // timer for every 15 seconds

pinMode(highwayHigh, OUTPUT);
pinMode(highwayLow, OUTPUT);
pinMode(bylineHigh, OUTPUT);
pinMode(bylineLow, OUTPUT);
pinMode(resHigh, OUTPUT);
pinMode(resLow, OUTPUT);
pinMode(22, OUTPUT);
pinMode(23, OUTPUT);
pinMode(24, OUTPUT);
pinMode(47,OUTPUT); //ldr to relay out pin
}
void loop(){
// read the input on analog pin 0:
int sensorValue1 = analogRead(A15);

```

```

// print out the value you read:
//Serial.println(sensorValue1);
//delay(1);
if(sensorValue1<50)
{
digitalWrite(highwayHigh, HIGH); // turn the LED on (HIGH is the voltage level)
digitalWrite(highwayLow,LOW);
delay(1999);          // wait for a second
digitalWrite(highwayHigh,LOW);
digitalWrite(highwayLow,HIGH);
}
// delay in between reads for stability

// read the input on analog pin 0:
int sensorValue2 = analogRead(A14);
// print out the value you read:
//Serial.println(sensorValue2);
//delay(1);
if(sensorValue2<50)
{
digitalWrite(bylineHigh, HIGH); // turn the LED on (HIGH is the voltage level)
digitalWrite(bylineLow,LOW);
delay(1999);          // wait for a second
digitalWrite(bylineHigh,LOW);
digitalWrite(bylineLow,HIGH);
}
// delay in between reads for stability

```

```

// read the input on analog pin :
int sensorValue3 = analogRead(A13);

// print out the value you read:
//Serial.println(sensorValue3);

//delay(1);

if(sensorValue3<50)
{
digitalWrite(resHigh, HIGH); // turn the LED on (HIGH is the voltage level)
digitalWrite(resLow,LOW);
delay(1999);          // wait for a second
digitalWrite(resHigh,LOW);
digitalWrite(resLow,LOW);
}

// delay in between reads for stability
=====//ldr works started

ldrReading=analogRead(A12); //get analog reading
if (ldrReading<20)
{
digitalWrite(47,HIGH);
}
else digitalWrite(47,LOW);
//Serial.println(ldrReading);
delay(10);

//ldr works end

digitalClockDisplay();

Alarm.delay(1000); // wait one second between clock display

```

```

digitalWrite(22,HIGH);
digitalWrite(23,HIGH);
digitalWrite(24,HIGH);
===== //these three pin for biasing BD139 transistor
}

//===== light check
void lightcheck() {
  int light11 = analogRead(A8);
  int light21 = analogRead(A9);
  int light31 = analogRead(A10);
  Serial.print("light value 11,21,31= ");
  Serial.print(light11);
  Serial.print(";");
  Serial.print(light21);
  Serial.print(";");
  Serial.print(light31);
  Serial.println();
  if(light11>800){
    sms.SendSMS("01759929678", "warning! Residential lamp No.1 Disconnected");
  }
  else if(light21>800){
    sms.SendSMS("01759929678", "warning! Bylane lamp No.2 Disconnected");
  }
  else if(light31>800){
    sms.SendSMS("01759929678", "warning! Highway lamp No.4 Disconnected");
  }
}

```

```
else{
    digitalWrite(13,LOW);
    Serial.println("Light Checked Passed");
}
```

```
}
```

```
=====// functions to be called when an alarm triggers:
```

```
void Evening(){
```

```
    Serial.println("evening: - turn lights on-high-all");
```

```
    digitalWrite(highwayHigh,HIGH);
```

```
    digitalWrite(bylineHigh,HIGH);
```

```
    digitalWrite(resHigh,HIGH);
```

```
    delay(100);
```

```
}
```

```
void TenPM(){
```

```
    Serial.println("10PM: - Highway High-Byline high-residensial-low");
```

```
    digitalWrite(highwayHigh,HIGH);
```

```
    digitalWrite(bylineHigh,HIGH);
```

```
    digitalWrite(resHigh,LOW);
```

```
    digitalWrite(resLow,HIGH);
```

```
    delay(100);
```

```
}
```

```
void ElevenPM(){
```

```
    Serial.println("11PM: - highway high-byline low-redensial-low");
```

```

digitalWrite(highwayHigh,HIGH);
digitalWrite(bylineHigh,LOW);
digitalWrite(bylineLow,HIGH);
digitalWrite(resHigh,LOW);
digitalWrite(resLow,HIGH);
delay(100);
}

void MidNight(){

Serial.println("MidNight: - highway low-byline low-residencial off");

digitalWrite(highwayHigh,LOW);
digitalWrite(highwayLow,HIGH);
digitalWrite(bylineHigh,LOW);
digitalWrite(bylineLow,HIGH);
digitalWrite(resHigh,LOW);
digitalWrite(resLow,LOW);
delay(100);
}

void Morning(){

Serial.println("Morning: - all off");

digitalWrite(highwayHigh,LOW);
digitalWrite(bylineHigh,LOW);
digitalWrite(resHigh,LOW);
digitalWrite(highwayLow,LOW);
digitalWrite(bylineLow,LOW);
digitalWrite(resLow,LOW);

```

```
    delay(1000);
}

void digitalClockDisplay()
{
    // digital clock display of the time
    Serial.print(hour());
    printDigits(minute());
    printDigits(second());
    Serial.println();
}

void printDigits(int digits)
{
    Serial.print(":");
    if(digits < 10)
        Serial.print('0');
    Serial.print(digits);
}
```