



BACHELOR OF SCIENCE IN ELECTRONIC AND TELECOMMUNICTAION
ENGINEERING

Design and Implementation of Underground Cable Fault Detection Systems Using IoT

Submitted by

**Asikur Rahman
T-173003**

Supervised by

Engr. MD Jiabul Hoque

Lecturer.
Dept. of CCE.
International Islamic University Chittagong
Kumira, Sitakunda, Chittagong - 4318
Bangladesh.

Department of Electronic and Telecommunication Engineering

International Islamic University Chittagong
Kumira, Sitakunda, Chittagong - 4318

November, 2022.

CERTIFICATE OF APPROVAL

The project report on “**Design and Implementation of Underground Cable Fault Detection Systems Using IoT**” Submitted by **Asikur Rahman (T-173003)** in partial fulfillment of the requirements for achieve the Bachelor degree of Science in Electronic and Telecommunication Engineering (ETE) and accepted as to style and contents by:

Board of Examiners

This thesis submitted by **Asikur Rahman, ID No. T173003**, in partial fulfillment of the requirements for the degree of Bachelor of Science in Electronic and Telecommunication Engineering (ETE) and accepted as to style and content by:

(Dr. Mohammad Rezaul Karim)
Professor and Head, Department of EEE
Chittagong Independent University
External Member

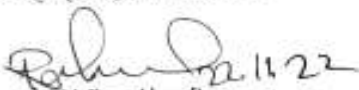
(Engr. Md. Razu Ahmed)
Professor
Dept. of CCE
International Islamic University Chittagong
Internal Member

(Engr. Abdul Gafur)
Associate Professor
Dept. of ETE
International Islamic University Chittagong
Convener

(Md. Jiabul Hoque)
Lecturer
Dept. of CCE
International Islamic University Chittagong
Supervisor

(Engr. Syed Zahidur Rashid)
Assistant Professor
Dept. of ETE
International Islamic University Chittagong
Internal Member &
Chairman



Approval of Supervisor

The Caption of this Project is "**Design and Implementation of Underground Cable Fault Detection Systems Using IoT**". This Project is submitted by **Asikur Rahman (T-173003)** to the department of Electronic and Telecommunication Engineering (ETE) of International Islamic University Chittagong (IIUC). It has been satisfactory for the partial fulfillment of the requirements for the Bachelor degree of Science in Electronic and Telecommunication Engineering (ETE). It was approved by our supervisor for the examination which held on 12 November 2022.

Approved by Supervisor

Engr. MD Jiabul Hoque

Lecturer

Department of Computer and Communication Engineering

International Islamic University Chittagong

Kumira, Sitakunda, Chittagong

Candidate Declaration

It is hereby declared that this work has been done entirely by us, and no part of the work contained in this thesis/project has been submitted elsewhere for the granting of any degree or diploma.

Asikur Rahman T-173003

Dedication

I want to dedicate our project work to all of our honorable teachers of ETE department. Specially, I want to dedicate our works to our supervisor sir. Because he encourages and guide us to complete our works properly. Then, I want to dedicate our project work to our parents. Because they support us to complete our bachelor degree.

Acknowledgement

At first, Thanks to Almighty Allah because we were able to complete our project work properly by the grace of Allah. All credit and glory go to Allah (SWT) for providing us with numerous opportunities and pouring His mercy and wisdom on us throughout our lives. We are grateful and indebted to **Engr. MD Jiabul Hoque**, our thesis supervisor, for his initiative in this field of research, valuable guidance, and encouragement throughout the research/thesis period. He always Support us. We are grateful to **Engr. Syed Zahidur Rashid**, Chairman of the Department of Electronic and Telecommunications Engineering at IIUC, for providing us with the best facilities in the department as well as timely recommendations. We also give thanks to our thesis/project Convener **Engr. Abdul Gafur** for his dedication and Sacrifices. We also thankful to our honorable teachers of ETE department. Every teacher of ETE department is very friendly. They help us to give important information such as Scholarship information. Every teacher of ETE department is very helpful. So, we want to thanks them. Finally, we want to thanks our parents who support us our good and bad times. Without our parents, we would not have been able to complete our graduation.

Abstract

Cables are put underground to stay away from pointless obstruction. These force cables convey electrical force and when these cables are put underground it is extremely hard to decide the specific area of the deficiency happened. There are numerous elements or purposes behind a deficiency to happen as, for example, burrowing, tremor, development work and so forth. As it don't have a clue about the specific area of the issue happened to the cable the fixing procedure identified with that cable is troublesome. Underground cable framework is a most basic practice followed in the urban zones. This paper is expected to find the flaw in an underground cable lines from the base station to a precise area in kilometers. The framework identifies flaw with the assistance of potential divider organize laid over the cable. When a defect is found in a cable line, a voltage gets produced according to the resistors organize blend. This voltage is detected by the microcontroller and is refreshed to the client.

Table of Contents

Certificate of Approval	2
Approval of Supervisor	3
Candidate Declaration	4
Dedication	5
Acknowledgement	6
Abstract	7
Chapter 1 INTRODUCTION	11
1.1 Background	11
1.2 Motivation	12
1.3 Objectives	122
1.4 Project Outline	13
Chapter 2 LITERATURE REVIEW	14
2.1 Introduction	14
2.2 Definition of Transmission System	14
2.3 Different Types Of Transmission Systems	15
2.4 Main Elements Of A Transmission Line	177
2.5 Summary of Previous Work	17
2.5.1 Underground Cable Fault Location Detection Using GSM	177
<i>Underground Cable Fault Detection System by Using IoT</i>	Error! Bookmark not defined.
2.3.3 The application of fiber optic distributed temperature sensor to fault detection of XLPE insulated underground cable	21
2.5.2 2.4 The proposed Underground transmissions line fault detection system	222
Chapter 3 DESIGN METHODOLOGY	23
3.1 Introduction	23
3.2 Design Stages	23
3.2.1 Stage 1 – Planning	23

3.2.2 Stage 2 – Analyzing	23
3.2.3 Stage 3 - Designing	24
3.2. Block Diagram	25
3.2.4 Stage 4 - Design implementation	26
3.2.5 Algorithm for implementing the designed system	27
Chapter 4 HARDWARE DESCRIPTION	29
4.1 Introduction:	29
4.2 Arduino Uno V3	30
4.3 MANUFACTURING	30
4.4 SAFETY	31
4.5 FCC COMPLIANCE	31
4.6 NOTE	31
4.7 TESTING	32
4.8 LIMITED WARRANTY STATEMENT	32
4.8.1 Consequential Damages Waiver.	33
4.8.2 Changes to Specifications.	34
4.8.3 Key Benefits	35
4.8.4 Key Applications	35
4.3 Relay Board Kit	37
4.3 ULN2003A	37
4.4 16X2 LCD	38
Chapter 5 SYSTEM DEVELOPMENT AND ANALYSIS	41
5.1 Introduction	41
5.2 Design of the underground cable fault detection system Observation Unit	41
5.3 Circuit Diagram of the Entire System	43
5.4 Entire System Prototype:	43

Chapter 6 RESULT AND DISCUSSION	44
6.1 Introduction	44
6.2 Project Outcome	44
6.3 Cost Analysis	46
Chapter 7 CONCLUSION	49
7.1 Introduction	49
7.2 Advantages and applications	49
7.3 Limitations	48
7.4 Future Work	50
REFERENCE	511
APPENDIX	52

Chapter 1

INTRODUCTION

1.1 Background

A bundle of electrical conductors used for carrying electricity is called as a cable. An underground cable generally has one or more conductors covered with suitable insulation and a protective cover. Commonly used materials for insulation are varnished cambric or impregnated paper. Fault in a cable can be any defect or non-homogeneity that diverts the path of current or affects the performance of the cable. So it is necessary to correct the fault. Power Transmission can be done in both overhead as well as in underground cables. But unlike underground cables the overhead cables have the drawback of being easily prone to the effects of rainfall, snow, thunder, lightning etc. This requires cables with reliability, increased safety, and ruggedness and greater services. So underground cables are preferred in many areas especially in urban places. When it is easy to detect and correct the faults in overhead line by mere observation, it is not possible to do so in an underground cable. As they are buried deep in the soil it is not easy to detect the abnormalities in them. Even when a faults is found to be present it is very difficult to detect the exact location of the fault. This leads to debugging of the entire area to detect and correct the fault which in turn causes wastage of money and manpower. So it is necessary to know the exact location of faults in the underground cables. Whatever the fault is, the voltage of the cable has the tendency to change abruptly whenever a fault occurs. We make use of this voltage across change resistors to detect the fault. In the event of short circuit (Line to Earth) fault, the voltage accordingly. It is then fed to an ADC to develop precise digital data that is directed to the programmed Arduino to display the same in kilometers. Hence this paper is very helpful for determining exact location of short circuit fault. This project is to determine underground cable fault using specific application. If the short circuit or any physical damage is occurred then the voltage across cable line changes. The changes which occurred can be calculated using CT theory. CT theory provide simple and accurate means of sensing current flow in power conductors. Signal conditioner manipulates the analog signal for the further processing. In this circuit we are used an Arduino UNO, Relays, ULN2003A, LCD, LEDs, Switches. ULN2003 is a high voltage and high current Darlington array IC. It contains seven open collector Darlington pairs with common emitters. A Darlington pair is an arrangement of two bipolar transistors. ULN2003 belongs to the family of ULN200X series of ICs. Different versions of this family interface to different logic families. ULN2003 is for 5V TTL, CMOS logic devices. These ICs

are used when driving a wide range of loads and are used as relay drivers, display drivers, line drivers etc. Each channel or Darlington pair in ULN2003 is rated at 500mA and can withstand peak current of 600mA. The objective of this project is to determine the distance of underground cable fault from the base station in kilometers. An underground cable system is quite common in many urban areas wherein it becomes very difficult to repair in case of any faults because finding the exact location of the fault in such cable system is quite difficult. With the proposed system, finding the exact location of the fault is possible. This project uses a standard concept of Ohms law, i.e. when a low DC voltage is applied at the feeder end through series resistor (assuming them as cable lines), then the current would vary depending upon the location of the fault in the cable. In case of a short circuit (line to ground), the voltage across the series resistors changes which is then fed to an ADC, to develop a precise digital data that gets displayed on the LCD. The project is assembled with a set of resistors representing cable length in km and fault creation is made by a set of switches at every known km to cross check the accuracy of the same. The fault that occurs at a particular distance of a particular phase is displayed on the LCD interfaced to the micro controller. Furthermore, this project can be enhanced by using a capacitor in an AC circuit to measure the impedance which can even locate an open-circuited cable, unlike short circuited fault only using resistors in DC circuit as followed in the above proposed project.

1.2 Motivation

A few month ago a huge fire broke out in a k khan Chattogram. Those fire occurred from electricity. If we ignore the service fault there still left some reason's which alert us a lot .One of them are power observation .Our transmission lines are not that much well connected or well observed . For that reason we decided to move to the underground portion .On the other hand we see in underground fault detection it's very difficult to detect fault .Only focused on productivity. For this reason we tried to make a solution which can reduce this problem.

1.3 Objectives

Underground fault detection will provide us a complete solution to detect current or voltage fault on underground transmissions lines. This monitoring is useful for the overall system that would like to avoid the upcoming loss that can occur by system. The overall objective of this

project is designed to develop an underground fault detection system for ensuring good power distribution and servicing system. The basic objectives of this project can be divided as:

- The project aim is to implement an underground fault detection observation system.
- Ensuring safe and efficient underground cable fault point detection.
- Designing and implementing reliable and low cost power based underground cable fault detection system using arduino.

1.4 Project Outline

In this, we described and discussed about our project in **seven** chapters. The outline of our project are as follows:

Chapter 1 “Introduction” shows the background, motivation and objectives of the project.

Chapter 2 “Literature review” discusses about the history and literature importance of this project. The history of the development of the underground fault detection system and discussion on some previous methods in this field.

Chapter 3 “Design Methodology” shows the implementation process and the working flowchart of the proposed system.

Chapter 4 “Hardware Description” describes the diagram, pin diagram and working principle of the hardware’s used in this automation projects.

Chapter 5 “Design Implementation and Analysis” shows the on field implementation of the system that has been designed.

Chapter 6 “Result and Discussion” Shows the performance analysis of the device with proper output.

Chapter 7 “Conclusion” Shows the advantages, limitation and future works of the proposed system.

Chapter 2

LITERATURE REVIEW

2.1 Introduction

Snehal C. Kor [1] in (2013) proposed Modified Murray Loop Method for Underground Cable Fault Location Detection Using GSM approach for detecting underground cable fault detection using mury loop method .In mury loop test we can perform short circuit test of underground cable fault point detection. Snehal C. Kor used mury loop method to find the fault location. He used GSM system to notify the user about fault location. He got 72% of efficiency in that project. Neha N. Badwaik [2] in (2013) proposed Underground Cable Fault Detection System by Using IoT approach for detecting underground cable fault detection using resonance circuit. In this system she used ESP8266 IoT module to send notification about underground cable fault location detection. She used offline method, online method, tester method to complete the whole experiment. She got 53% efficiency on her experiment. Xiaohong Zhang [3] in (2002) proposed the application of fiber optic distributed temperature sensor to fault detection of XLPE insulated underground cable approach for detecting underground cable fault detection. He used pulse radar method to detect underground cable fault. In his experiment he used XLPE insulated system to detect underground cable fault. He got 47% efficiency on his experiment. We have discussed those three different experiment on underground cable fault detection below.

2.2 Definition of Transmission System

Electrical energy, after being produced at generating stations (TPS, HPS, NPS, etc.) is transmitted to the consumers for utilization. This is due to the fact that generating stations are usually situated away from the load centers. The network that transmits and delivers power from the producers to the consumers is called the transmission system. This energy can be transmitted in AC or DC form. Traditionally, AC has been used for years now, but HVDC (High Voltage DC) is rapidly gaining popularity.

Electrical power is normally generated at 11kV in a power station. While in some cases, power may be generated at 33 kV. This generating voltage is then stepped up to 132kV, 220kV, 400kV or 765kV etc. Stepping up the voltage level depends upon the distance at which power is to be transmitted. Longer the distance, higher will be the voltage level. Stepping up of voltage is to reduce the I²R losses in transmitting the power (when voltage is stepped up, the current reduces by a relative amount so that the power remains constant, and hence I²R loss also reduces). This stage is called as primary transmission.

The voltage is the stepped down at a receiving station to 33kV or 66kV. Secondary transmission lines emerge from this receiving station to connect substations located near load centers (cities etc.).

The voltage is stepped down again to 11kV at a substation. Large industrial consumers can be supplied at 11kV directly from these substations. Also, feeders emerge from these substations. This stage is called as primary distribution.

Feeders are either overhead lines or underground cables which carry power close to the load points (end consumers) up to a couple of kilometers. Finally, the voltage is stepped down to 415 volts by a pole-mounted distribution transformer and delivered to the distributors. End consumers are supplied through a service mains line from distributors. The secondary distribution system consists of feeders, distributors and service mains.

2.3 Different Types of Transmission Systems

1. Single phase AC system | single phase, two wires |
single phase, two wires with midpoint earthed |
single phase, three wires
2. Two phase AC system | two-
phase, three wires | two-
phase, and four wires
3. Three phase AC system |
three-phase, three wires |
three-phase, four wires
4. DC system | DC two wires | DC two wires
with midpoint earthed | DC three wires

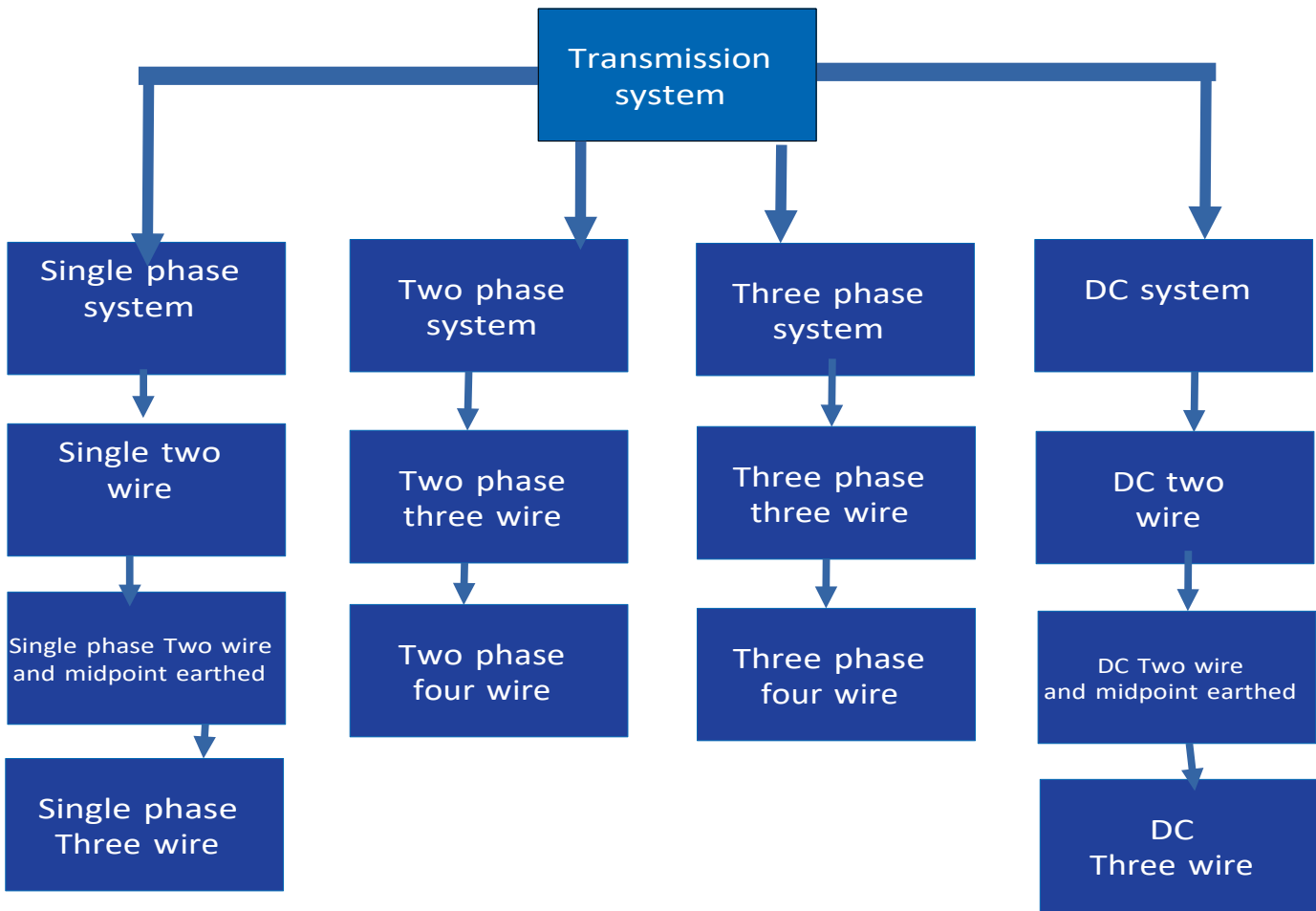

Fig 2.1: classification of transmission line system.

Electric power transmission can also be carried out using underground cables. But, construction of an underground transmission line generally costs 4 to 10 times than an equivalent distance overhead line. However, it is to be noted that, the cost of constructing underground transmission lines highly depends upon the local environment. Also, the cost of conductor material required is one of the most considerable charges in a transmission system. Since conductor cost is a major part of the total cost, it has to be taken into consideration while designing. The choice of transmission system is made by keeping in mind various factors such as reliability, efficiency and economy. Usually, overhead transmission system is used.

2.4 Main Elements of a Transmission Line

Due to the economic considerations, three-phase three-wire overhead system is widely used for electric power transmission. Following are the main elements of a typical power system.

Conductors: three for a single circuit line and six for a double circuit line. Conductors must be of proper size (i.e. cross-sectional area). This depends upon its current capacity. Usually, ACSR (Aluminum-core Steel-reinforced) conductors are used.

Transformers: Step-up transformers are used for stepping up the voltage level and step-down transformers are used for stepping it down. Transformers permit power to be transmitted at higher efficiency.

Line insulators: to mechanically support the line conductors while electrically isolating them from the support towers.

Support towers: to support the line conductors suspending in the air overhead.

Protective devices: to protect the transmission system and to ensure reliable operation. These include ground wires, lightning arrestors, circuit breakers, relays etc.

Voltage regulators: to keep the voltage within permissible limits at the receiving end.

2.5 Summary of Previous Work

Because of the progression of wireless technology, there are a few different advancements were presented, for example, Mury loop method, pulse radar method and resonance methods. Each technology has its very own unique specifications and applications.

Previously, they have used various experiment over underground cable fault point detection. In those methods, cable fault detection was pretty coast effective. Sometimes it was difficult to maintain. Those project has been described elaborately:

2.5.1 *Underground Cable Fault Location Detection Using GSM*

In this project, they used Mury Loop method to detect underground cable fault detection. They used short circuit test on their project. They used GSM module in their project to show output.

Snehal C. Kor , “Murray Loop Method for Underground Cable Fault Location Detection Using GSM” used short circuit test to examine the underground cable fault point detection. Murray loop test, Varley loop test and Pulse Echo test are simple basic method to detect cable fault point testing. This method used basic equipment that obtained easily. These tests are performed for the fault point of either an earth fault or short circuit fault in underground cable. In these tests the resistance of fault does not affect the results obtained except when the resistance of fault is very high. There are two loop tests used and they are known as MurrayLoop and Varley Loop Test. These tests used the principle of Wheatstone bridge.

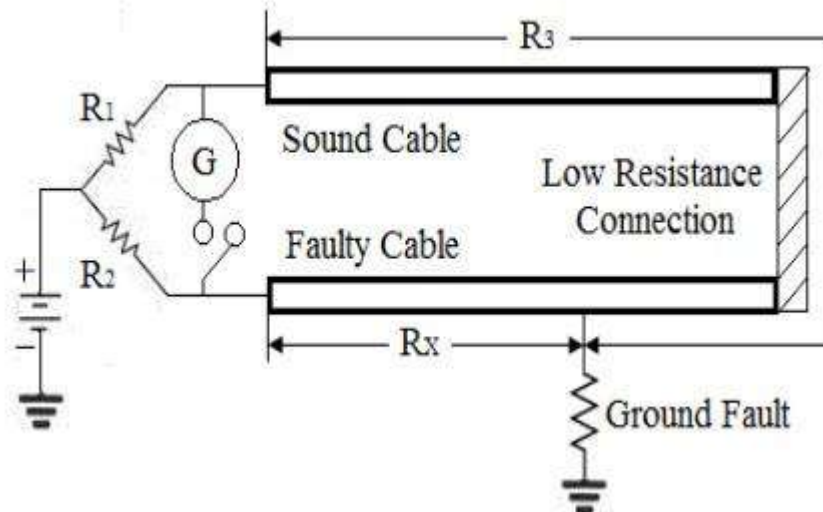

Fig2.2.1: Mury loop ground fault detection system [1].

In this test, the faulty cable is connected with sound cable by a low resistance wire, because that resistance should not affect the total resistance of the cable and it should be able to circulate the loop current to the bridge circuits without loss.

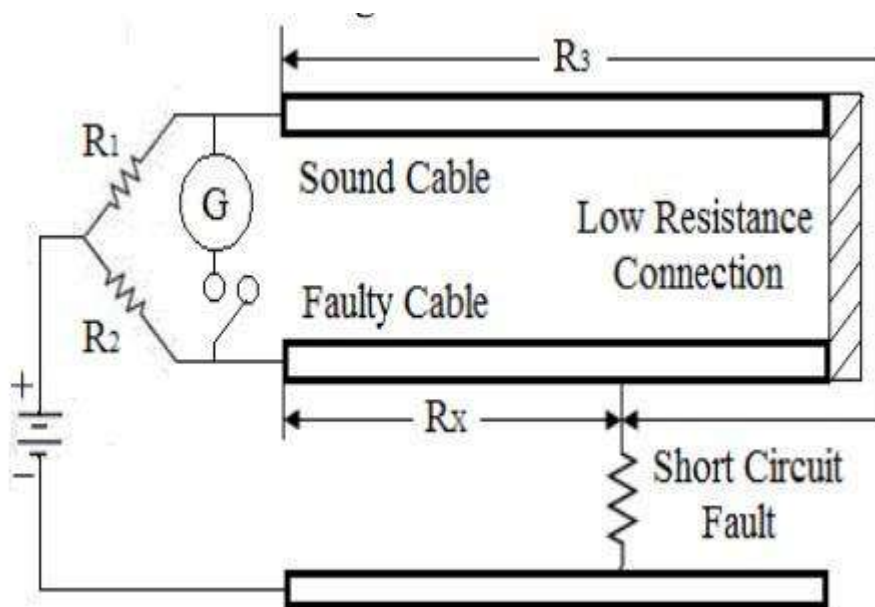

Fig2.2.2: Mury loop short circuit test [1].

The variable resistors R_1 and R_2 are forming the ratio arms. Balance of the bridge is achieved by adjusting the variable resistors. „G is the galvanometer to indicate the balance. $[R_3 + R_X]$ “ is the galvanometer to indicate the balance. $[R_3 + R_X]$ is the total loop resistance formed by the sound cable and the faulty cable.

Neha N. Badwaik [2] designed Underground Cable Fault Detection System by Using IoT. In her system users notified about underground cable fault point with three phase.

They are:

1. Online method
2. Offline method
3. Testing method

The proposed system is an IoT enabled underground cable fault detection system. The main principle behind the system is the Ohm's law. When the fault causes in the cable, the voltage varies which is used to measure the fault distance. The system consists of a ESP8266 module, Micro-controller, and Real-Time Clock. The block diagram of the fault detection system is shown in Figure 2.3.1 the power supply is provided using a step-down transformer, rectifier and regulator. The current measurement circuit of the cable provides the magnitude of the voltage drop across the resistors to the micro-controller and based on the voltage the fault distance is located.

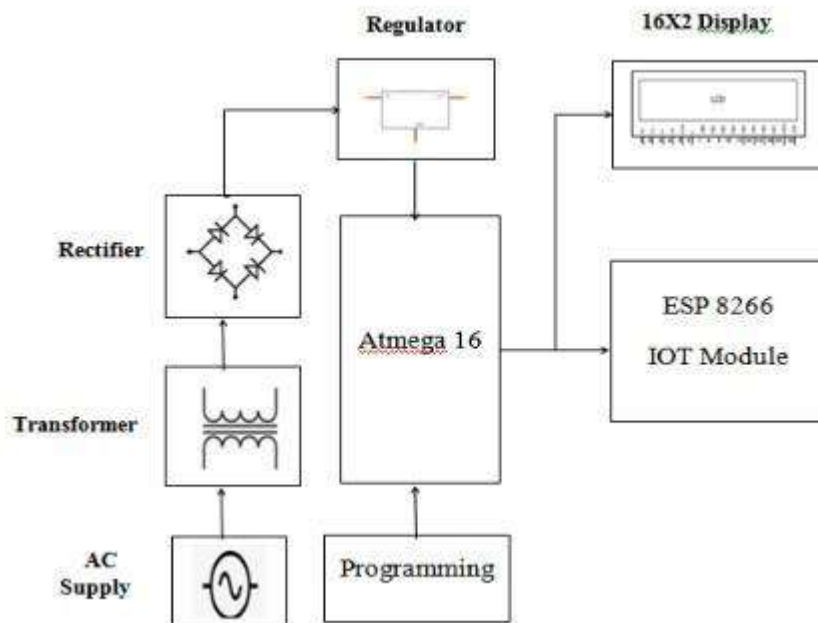

Fig2.3.1: Block diagram of IoT based underground cable fault detection system [2].

The project uses the simple concept of Ohms law where a low DC voltage is applied at the feeder end on a series resistor. The current would vary depending upon the length of the cable fault in case there is a short circuit of LL or 3L or LG etc. The series resistor voltage drop changes accordingly which are then fed to an ADC to develop precise digital data in which the programmed micro-controller would display the same. This designed model of an underground cable fault distance locator using a micro-controller. It is classified into four parts DC power supply part, cable part, controlling part, display part. DC power supply part consist of an ac supply of 230V is step down using a transformer, bridge rectifier converts ac signal to DC and the regulator is used to produce constant dc voltage. The cable part is denoted by a set of resistors along with switches. The current sensing part of cable represented as a set of Potentiometer are used as fault creators to indicate the fault at each location. This part senses the change in current by sensing the voltage drop. Next is the controlling part which consists of analog to digital converter which receives input from the current sensing circuit, converts this voltage into a digital signal and feeds the microcontroller with the signal. The micro-controller also forms part of the controlling unit.

2.3.3 *The application of fiber optic distributed temperature sensor to fault detection of XLPE insulated underground cable*

Xiaohong [3] in 2003 proposed “The application of fiber optic distribution temperature sensor to fault detection of XLPE insulated underground cable” system, tried to developed underground cable fault detection in such a way that they used pulse detection of XLPE insulated underground cable for detecting cable fault point.

Although Murray loop method and pulse radar method have been extensively used for cable fault locating, the fault line needs to be removed from service and connected to detection equipment, which will take much time and effort. In the present paper, a new fault location method, which integrates fiber optic distributed temperature (FODT) sensor into cable, is introduced. The FODT sensor, which is applied to fault detection of XLPE insulated underground cable in resistance grounded power system, can find fault point immediately. The maximum detection distance, distance resolution and processing time for fault location are 10 km, 1 m and 30 s respectively.

2.5.22.4 The proposed Underground transmissions line fault detection system

Technology is updating day by day. Various technologies used in previous days. All system has some drawbacks. Some system uses conventional technology. Some system uses modern technology but they also have some limitations in monitoring which relates to the automation system. A fault in electrical equipment can be defined as a defect in its electrical circuit due to which the current is diverted from the intended path. Faults are generally caused by mechanical failure, accidents, excessive internal, external stresses and others. When a cable is faulty the resistance of such cable is affected. If left unrectified, it will totally hinder voltage from flowing through the cable. The challenge with the existing methods used for locating faults in underground cables is the inaccuracy in calculating the distance where the fault is located and the low durability of such equipment. To overcome these challenges, this project presents a novel underground cable fault detector that has the capacity to measure the resistance of the cable, detect the type of fault in a cable and also accurately compute the location of the fault using cheap materials. Several tests were conducted using the designed device, and the results indicated that the designed method produced satisfactory results in detecting both open circuit and short circuit problem in underground cables within a maximum distance of 10-km.

Chapter 3

DESIGN METHODOLOGY

3.1 Introduction

The project entitled “Underground cable fault detection system”. Observation of desired data voltage, current, temperature, observation and fault detection will be possible. In this project we use voltage converter, bread board power adapter, dual relay module, LCD, microcontroller, temperature sensor, power voltmeter,ammeter,2volt ULN2003A module .All the information will be shown on a LCD so that we can know the running state of this device.

3.2 Design Stages

To complete the project we have followed four steps. Which are-

1. Planning
2. Analyzing
3. Designing and
4. Design implementation

3.2.1 Stage 1 – Planning

At the first stage of our project we consulted with our supervisor to select a project. With the consultation of supervisor we select this project and named this project as “UNDERGROUND CABLE FAULT DETECTION OBSERVATION”. Then we studied the background work on this field and found some fruitful previous work. We found that technology is almost new. In previous work there were some limitations which might be cover in this new technology. So we planned and developed our project to overcome those limitations.

3.2.2 Stage 2 – Analyzing

After planning about the project we started analyzing about some of the underground cable fault detection system that has been made before. We downloaded some papers from IEEE web page which helped us during analyzing. We also watched many videos on YouTube on this field. We did our literature review section according to this analysis. Then we analyzed

the hardware's operation and their specifications that we are using. Study on suitable programming language and different platforms are important to ensure that the programming language is sufficient to build the proposed system and how to integrate different modules with different platforms into a meaningful system to provide useful information to the user. We also analyzed the previous works in our university on this field. We found a few works in this field with various technologies. We tried to overcome the limitations of previous work.

3.2.3 Stage 3 - Designing

The main project constructing process starts from this stage. Here the entire system will be theoretically designed which will be implemented in the implementation section.

3.2. Block Diagram

This circuit has been designed over arduino based micro-controller system. All the components are directly or partially connected with arduino Uno. First of all we designed an array of resistor with bunch of switches. We decided them into three section. Each push switches return a different resistance value. Those values are connected to each relay driver modules. Now our relay driver modules are connected to ULN2003 relay driver. This driver helps to controls digital pins of arduino to detect fault location distance. We measures the fault point location by defining the resistance drop over transmission line. Then after gaining the fault point location distance we have shown the output on out LCD.

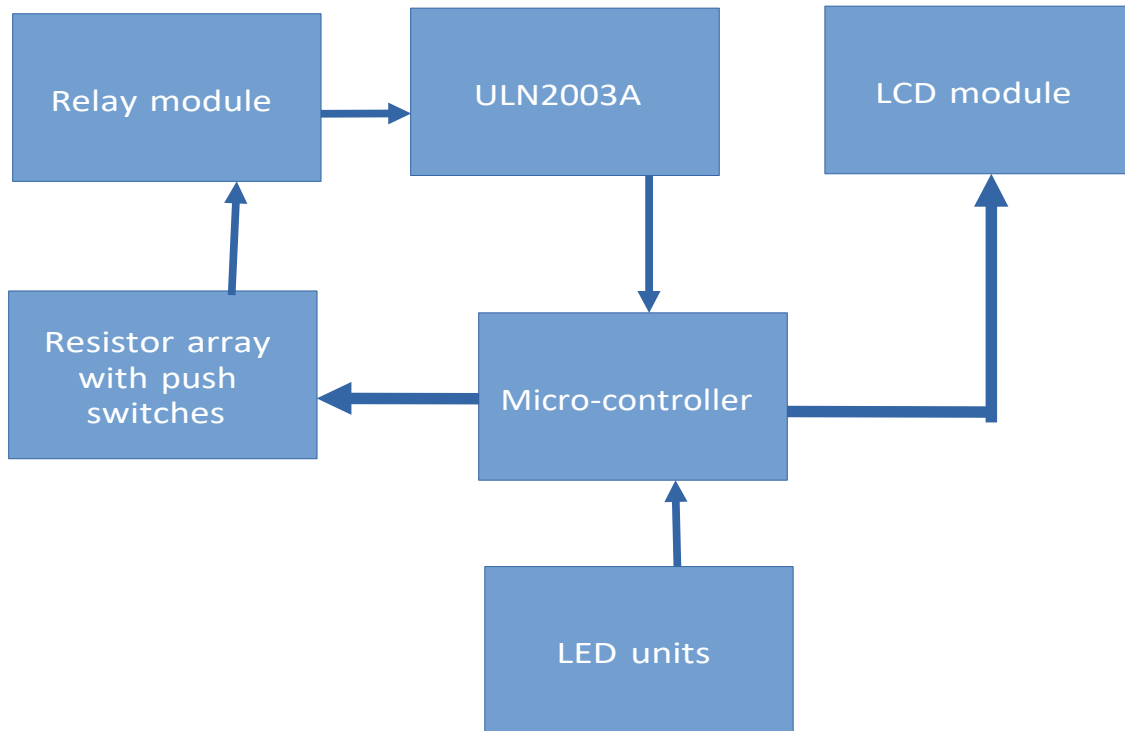

Fig 3.1: Block Diagram of Designed Project

Here is the complete block diagram representation of the industrial automation system. Every systems and sub-systems are depicted from where its operating procedure can be described. Various sensor modules are connected with system. LCD which uses as a monitor in this project. Voltage, current, temperature will be shown on it and the signal point measuring the detected region the show the faulty node of cable transmission line.

3.2.4 Stage 4 - Design implementation

After the completion of all the designs and developments, we started implementing the theoretical designs where all the hardware's are implemented and functionality is checked.

Then we assembled every parts of our system according to our design. First, we built a base for the entire system. Then we assembled the sensors according to pin diagram and checked their functionality. After that we connected the LCD module to get the result. Finally, after all the hardware works been done final testing has been performed and results are noted.

3.2.5 Algorithm for implementing the designed system

The algorithm of the Design and Implementation of IoT Based Different Underground Cable Fault Detection Systems Using Copper Cable Resistance is discussed in this section. At first the system initializes all the module, device and sensors. Then the system waits for getting all the values. When the system get all data, it sends those data to the controller from where we can see the output through LCD. If the system does not get fault data, it again searches for the fault value. Such this way, the system repeats the loop and hence we can get our desired output result. The flow chart of the system is shown in **Fig 3.2** Which shows how all the systems are interconnected and interact with each other.

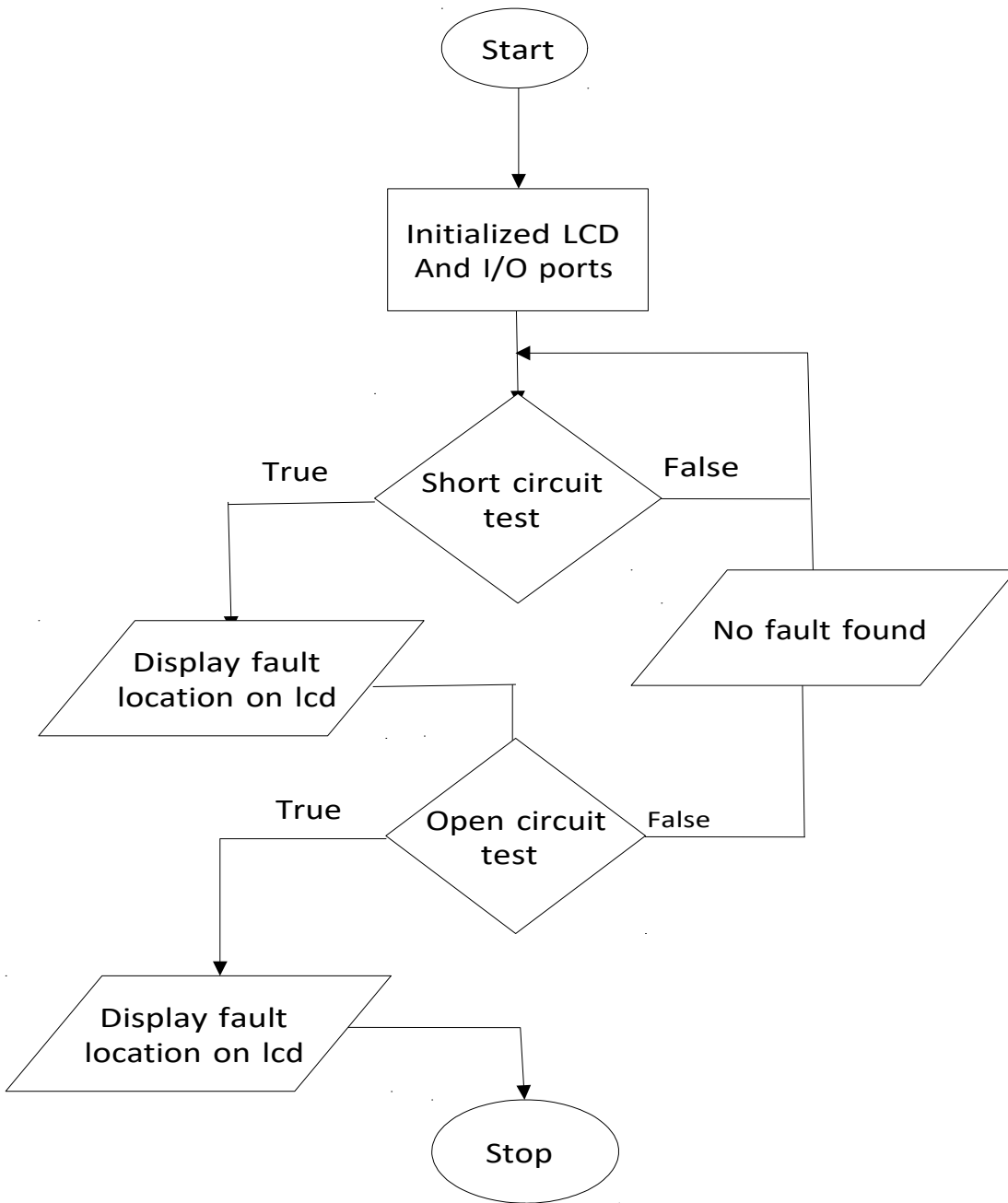

Fig3.2: Flow chart of underground cable fault detection system.

Chapter 4

HARDWARE DESCRIPTION

4.1 Introduction:

The development of this project is based on several types of module and sensor. Major equipment's are:

1. Arduino
2. Relay module
3. ULN2003A
4. 1k resistors
5. 16x2 LCD
6. I2C
7. Push Switch
8. Led
9. Bread board

4.2 Arduino Uno V3

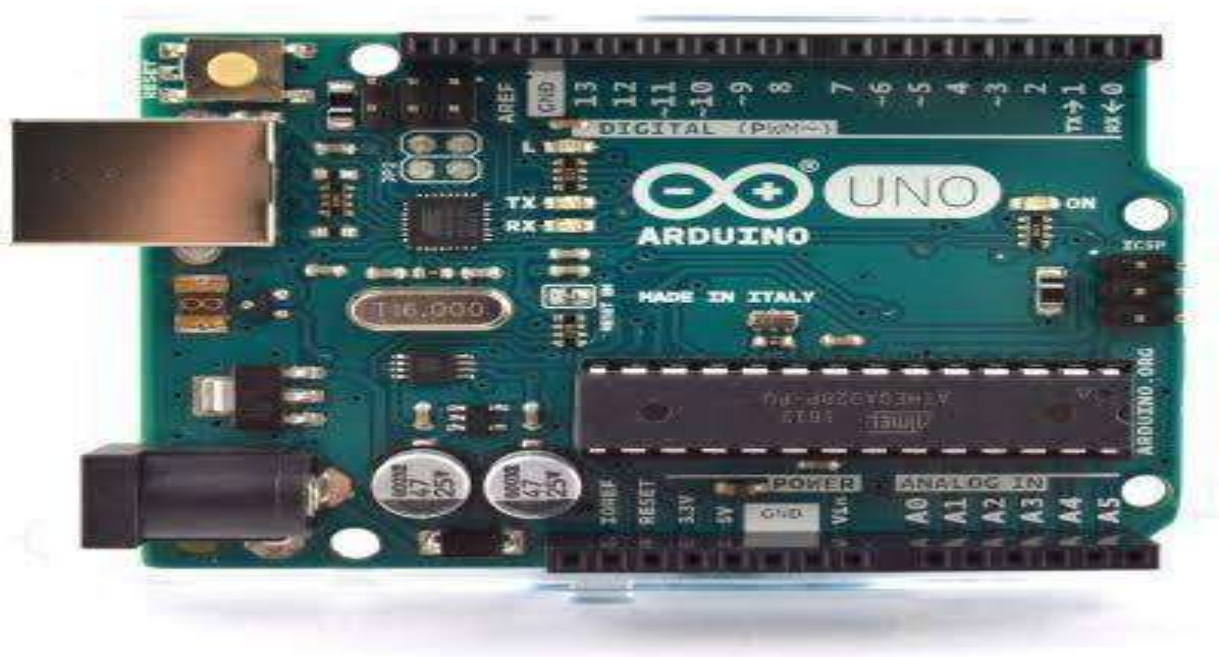

Fig 4.1: Arduino uno v3[4]

Arduino/Genuino products intended for sale and use in worldwide markets comply with the applicable international requirements for product safety, electromagnetic compatibility (EMC), essential safety & usage information, WEEE, RoHS, quality, and for use in hazardous locations. Products delivered into the European Economic Area (EEA) comply with the directives of the European Community (EC). Products delivered into North America comply with their respective directives. The products bears CE and/or FCC marks which is tested and certified by Arduino to comply with the EC and/or USA directives.

4.3 MANUFACTURING

All components and solder alloys used in this product comply with the RoHS Directive. The RoHS Directive prevents all new electrical and electronic equipment placed on the market in the European Economic Area from containing more than agreed levels of lead, cadmium, mercury, hexavalent chromium, poly-brominated biphenyls (PBB) and poly-brominated diphenyl ethers (PBDE).

4.4 SAFETY

All boards are labelled with the FCC and CE logo, as they meet the electromagnetic compatibility standards set in their respective jurisdictions. Arduino/Genuino products meet the essential requirements of EU Directive 2001/95/CE General directive on products safety and Directive 93/68/CE.

4.5 FCC COMPLIANCE

This device complies with Part 15 of the FCC Rules. Operation is subject to the following two conditions: (1) this device may not cause harmful interference, and (2) this device must accept any interference received, including interference that may cause undesired operation.

4.6 NOTE

This equipment has been tested and found to comply with the limits for a Class B digital device, pursuant to part 15 of the FCC Rules. These limits are designed to provide reasonable protection against harmful interference in a residential installation. This equipment generates, uses and can radiate radio frequency energy and, if not installed and used in accordance with the instructions, may cause harmful interference to radio communications. However, there is no guarantee that interference will not occur in a particular installation. If this equipment does cause harmful interference to radio or television reception, which can be determined by turning the equipment o and on, the user is encouraged to try to correct the interference by one or more of the following measures:

- Reorient or relocate the receiving antenna;
- Increase the separation between the equipment and receiver;
- Connect the equipment into an outlet on a circuit different from that to which the receiver is connected;
- Consult the dealer or an experienced radio/ TV technician for help.

The following parties are responsible for the compliance of radio frequency equipment with the applicable standards: in the case of equipment subject to authorization under the verification procedure, the manufacturer or, in the case of imported equipment, the importer. If subsequent to manufacture and importation, the radio frequency equipment is modified by any

party not working under the authority of the responsible party, the party performing the modification becomes the new responsible party.

4.7 TESTING

Products are subject to triple testing to make sure they are not faulty:

→ first, printed circuit boards are thoroughly tested for short circuits and open connections.

→ Then, boards are powered (and, in products containing a micro-controller, the boot loader is programmed) to check there are no macroscopic problems preventing the board from turning on.

→ Finally, the most in-depth test: the board is placed into a custom bed of nails tester, and programmed by a test program, which checks its overall functionality. All boards are tested to meet USA and EU consumer safety, health and environmental requirements.

4.8 LIMITED WARRANTY STATEMENT

4.2.1 Warranties:

4.2.1.1 **Arduino LLC** warrants that its products will conform to the Specifications. If the board is bought outside the EU this warranty lasts for one year from the date of the sale. If the board is bought in the EU this warranty lasts for two years from the date of the sale. Arduino LLC shall not be liable for any defects that are caused by neglect, misuse or mistreatment by the Customer, including improper installation or testing, or for any products that have been altered or modified in any way by the Customer. Moreover, Arduino LLC shall not be liable for any defects that result from the Customer's design, specifications or instructions for such products. Testing and other quality control techniques are used to the extent Arduino LLC deems necessary.

4.2.1.2 If any Arduino LLC product fails to conform to the warranty set forth above, Arduino LLC's sole liability shall be to replace such products. Arduino LLC's liability shall be limited to products that are determined by Arduino LLC not to conform to such warranty. If Arduino LLC elects to replace such products, Arduino LLC shall be given a reasonable time to provide replacements. Replaced products shall be warranted for a new full warranty period.

4.2.1.3 This limited warranty is the end-user's sole and exclusive remedy against arduino where permitted by law. and subject to section (3). except as set forth above, products are provided "as is" and "with all faults". arduino llc disclaims all other warranties, express or implied, regarding products, including, but not limited to, any implied warranties of merchant ability or fitness for a particular purpose.

4.2.1.4 The Customer agrees that prior to using any systems that include Arduino LLC products, the Customer will test such systems and the functionality of the products as used in such systems. Arduino LLC may provide technical, applications or design advice, quality characterization, reliability data or other services. The Customer acknowledges and agrees that providing these services shall not expand or otherwise alter Arduino LLC's warranties, as set forth above, and that no additional obligations or liabilities shall arise from Arduino LLC providing such services.

4.2.1.5 Arduino LLC products are not authorized for use in safety-critical applications where a failure of the Arduino LLC product would reasonably be expected to cause severe personal injury or death. Safety-critical applications include, without limitation, life support devices and systems, equipment or systems for the operation of nuclear facilities and weapons systems. Arduino LLC products are neither designed nor intended for use in military or aerospace applications or environments, nor for automotive applications or the automotive environment. The Customer acknowledges and agrees that any such use of Arduino LLC products is solely at the Customer's risk, and that the Customer is solely responsible for compliance with all legal and regulatory requirements in connection with such use.

4.2.1.6 The Customer acknowledges and agrees that the Customer is solely responsible for compliance with all legal, regulatory and safety-related requirements concerning the products and any use of Arduino LLC products in the Customer's applications, notwithstanding any applications-related information or support that may be provided by Arduino LLC.

4.8.1 Consequential Damages Waiver.

In no event shall Arduino LLC be liable to the Customer or any third parties for any special, collateral, indirect, punitive, incidental, consequential or exemplary damages in connection with or arising out of the products provided hereunder, regardless of whether Arduino LLC has

been advised of the possibility of such damages. This section will survive the termination of the warranty period.

4.8.2 Changes to Specifications.

Arduino LLC may make changes to specifications and product descriptions at any time, without notice. The Customer must not rely on the absence or characteristics of any features or instructions marked “reserved” or “undefined”. Arduino LLC reserves these for future definition and shall have no responsibility whatsoever for conflicts or incompatibilities arising from future changes to them. The product information on the Web Site or Materials is subject to change without notice. Do not finalize a design with this information.

4.2.1.9 Statutory laws. *

- (i) Some countries, regions, states or provinces do not allow the exclusion or limitation of remedies or of incidental, punitive, or consequential damages, or the applicable time periods, so the above limitations or exclusions may not apply.
- (ii) except to the extent lawfully permitted, this limited warranty does not exclude, restrict or modify statutory rights applicable to where the product is sold but, rather, is in addition to these rights.

4.2.1.10 Arduino Pin Configuration:

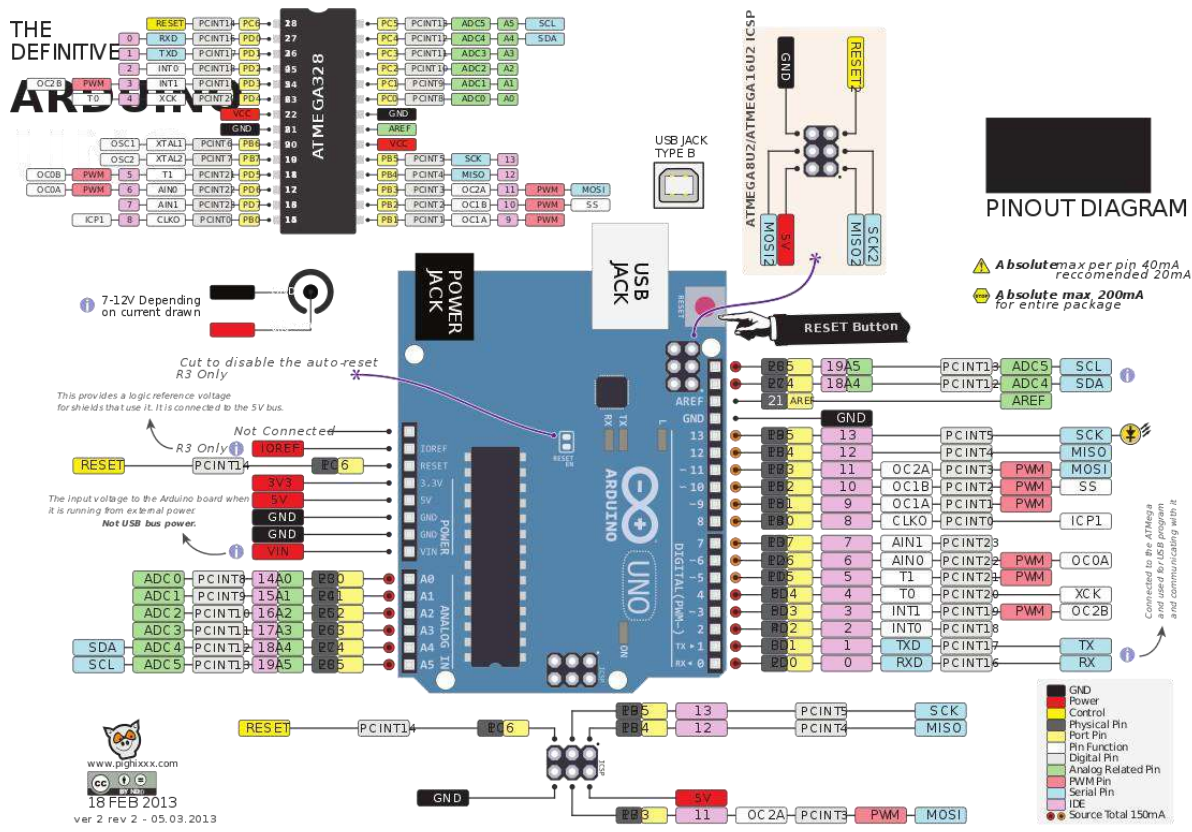

Fig 4.2: Arduino Pin Configuration [5]

Fig4.2 Shows Arduino GPIO Header Pin Configuration

4.8.3 Key Benefits

- Low cost
- Consistent board
- 10x faster processing
- Added connectivity

4.8.4 Key Applications

- Low cost PC/tablet/laptop
- IoT application

- Media center
- Robotics
- Industrial/Home automation
- Server/cloud server
- Print server
- Security monitoring
- Web camera
- Gaming
- Wireless access point
- Environmental sensing/monitoring (e.g. weather station)

Features:

1 Broadcom BCM2837B0, Cortex-A53 (ARMv8) 64-bit SoC @ 1.4GHz

1 1GB LPDDR2 SDRAM

1 2.4GHz and 5GHz IEEE 802.11.b/g/n/ac wireless LAN, Bluetooth 4.2, BLE 1 Gigabit Ethernet over USB 2.0 (maximum throughput 300 Mbps) 1 Extended 40-pin GPIO header 1 Full-size HDMI 1 4 USB 2.0 ports

1 CSI camera port for connecting a Raspberry Pi camera 1 DSI display port for connecting a Raspberry Pi touchscreen display 1 4-pole stereo output and composite video port

1 Micro SD port for loading your operating system and storing data

1 5V/2.5A DC power input

1 Power-over-Ethernet (PoE) support (requires separate PoE HAT)

4.3 Relay Board Kit

The Dual Relay Board can be used to turn lights, fans and other devices on/off while keeping them isolated from your micro-controller. Once properly assembled, the Dual Relay Board Kit allows you to control two high-power devices (up to 8 A) via the included Omron mechanical relays. Independent control of each relay is provided via a 2 x 3 header — friendly to servo cables and convenient connection to many development boards, such as the Board of Education, Propeller Board of Education, Professional Development Board and Propeller Professional Development Board. LEDs indicate relay status.



Fig:4.3 Relay module [6]

4.3 ULN2003A

ULN2003A is a relay driver IC. We have used this IC for measuring induced voltage across relay input, as we know after switching we get some dropped voltage from the resistor array. Those voltage occurs variation in induced voltage in relay input. Now we connected our UIN2003A IC on output channel of the relay module, So that we can measure voltage drop from input channel.

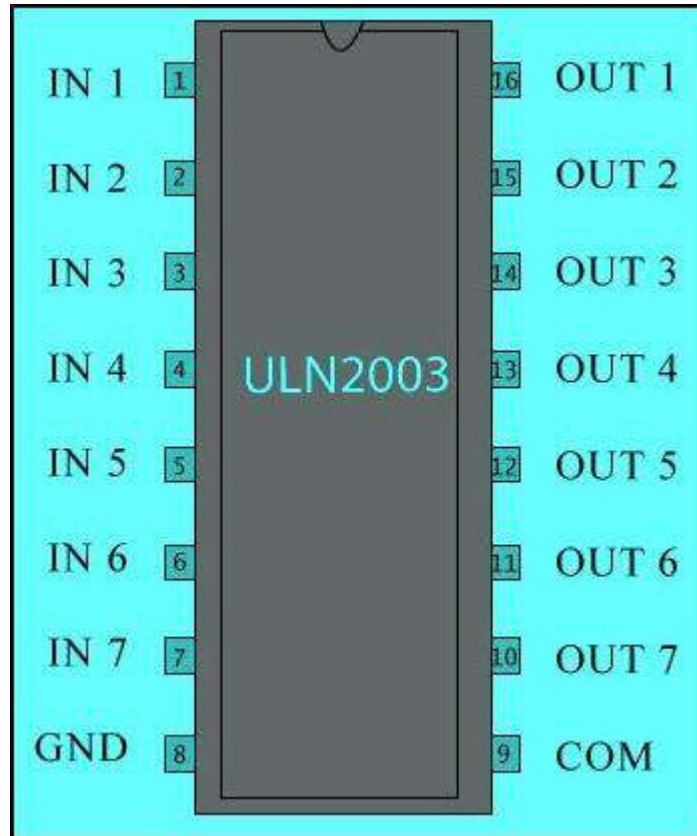

Fig4.4: ULN2003A block diagram [7]

The IC ULN2003A is a Darlington transistor array which deals with high-voltage and high current. There are various types of relay driver ICs such as a high side toggle switch, low side toggle switch, bipolar NPN transistor, Darlington transistor, N-channel MOSFET, ULN2003 driver IC. The pin diagram of IC ULN2003A is shown in the above figure which consists of 16 pins. The IC ULN2003A comprises of 7-NPN Darlington pairs as shown in the internal schematic diagram and is typically used to switch inductive loads (dissipates voltage spikes if any using suppression diode) and to drive stepper motors.

4.4 16X2 LCD

We have used 16x2 LCD to show the output of our project. It has two row and 16 column in it. So we can easily execute two string line on it. We used 16x2 LCD to show underground cable fault location point. Most of our measurement have been shown in this module, only few output function has been shown in led units.

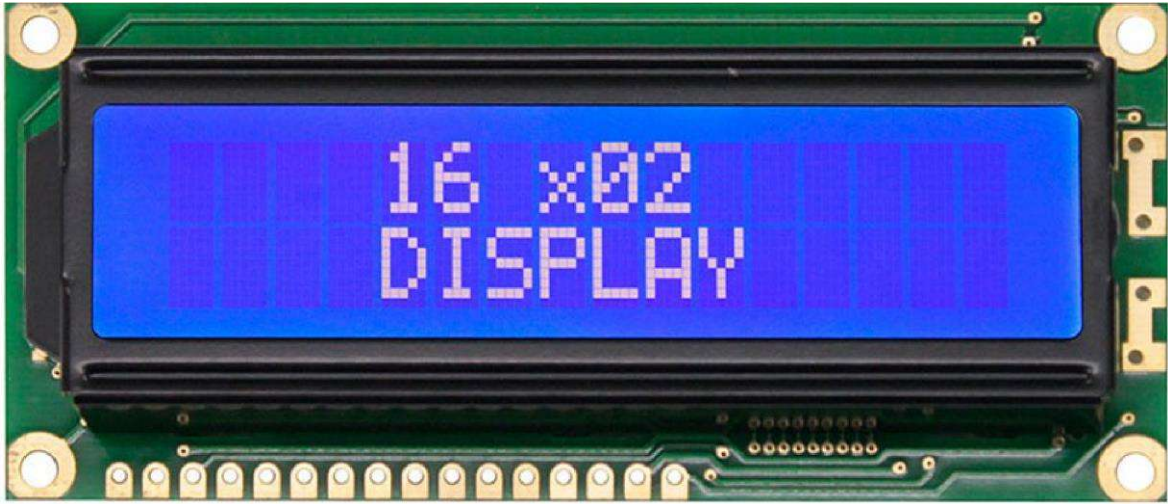

Fig4.5: 16x2 LCD [8]

LCD display module with Blue Back light

- SIZE : 20×4 (2 Rows and 16 Characters Per Row)
- Built-in industry standard HD44780 equivalent LCD controller
- Commonly Used in: Student Project, Collage, copiers, fax machines, laser printers, industrial
- Test equipment, networking equipment such as routers and storage devices. Operate with 5V DC LCD type: Characters.

4.5 I2c module:

We have used I2C module to easily implement LCD circuit. We used ad fruit character led library to implement I2C with LCD. It has four pin to connect with arduino. They are:

1. VCC
2. Ground
3. SDA
4. SCL

It has 16pin in common connection with LCD display units.

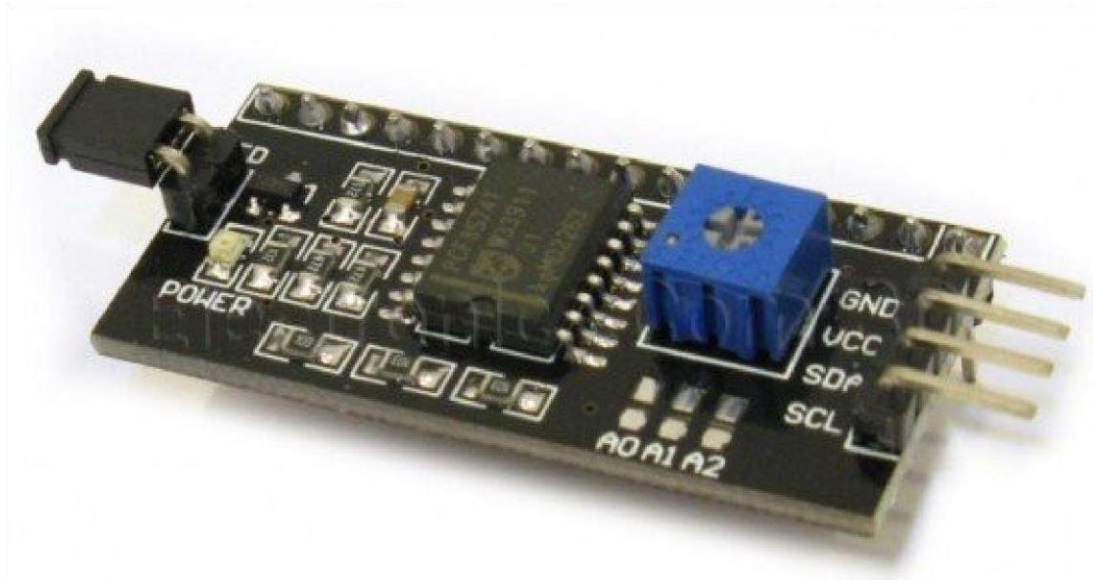

Fig4.6:I2C module [9]

- 1) This board is used to drive the LCD 1602 or LCD 2004 through I2C communication.
- 2) Reduce the number of pins used to connect from LCD module to Arduino board.
- 3) Operating voltage: 5Vdc.
- 4) Based on PCF8574 chip.
- 5) Power LED indicator.
- 6) Jumper cap for LCD back light.
- 7) LCD contrast is adjustable through potentiometer.
- 8) Select-able I2C address. Default is 0x27.
- 9) Dimension: 41 x 19 mm.
- 10) Weight: 7g.

Chapter 5

SYSTEM DEVELOPMENT AND ANALYSIS

5.1 Introduction

This chapter is all about implementing and the theoretical concepts into reality. This chapter describes the detailed design of each block of the proposed has along with the working of each part. Each block comprises of a few parts associated in the expected method to give the desired output. The complete circuit diagram is provided at the end based on which the fabrication was completed. Here the entire system is assembled and its performance is analyzed.

5.2 Design of the underground cable fault detection system Observation Unit

A remote methodology can supplant the wire outfit inside home system detecting and control system applications. With the self-arrangement and self-association advancements a smart control system can be developed with the use automation. Figure 5.1 shows the design of the fault current automation controlling unit.

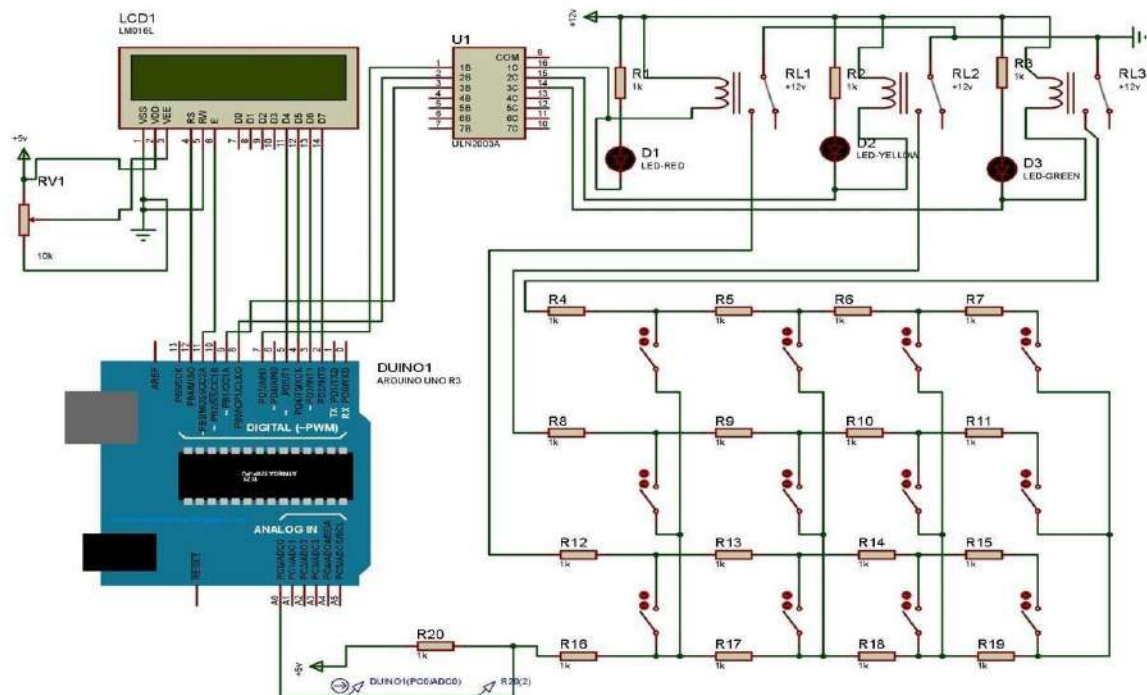

Fig 5.1: Underground fault detection system circuit diagram [10]

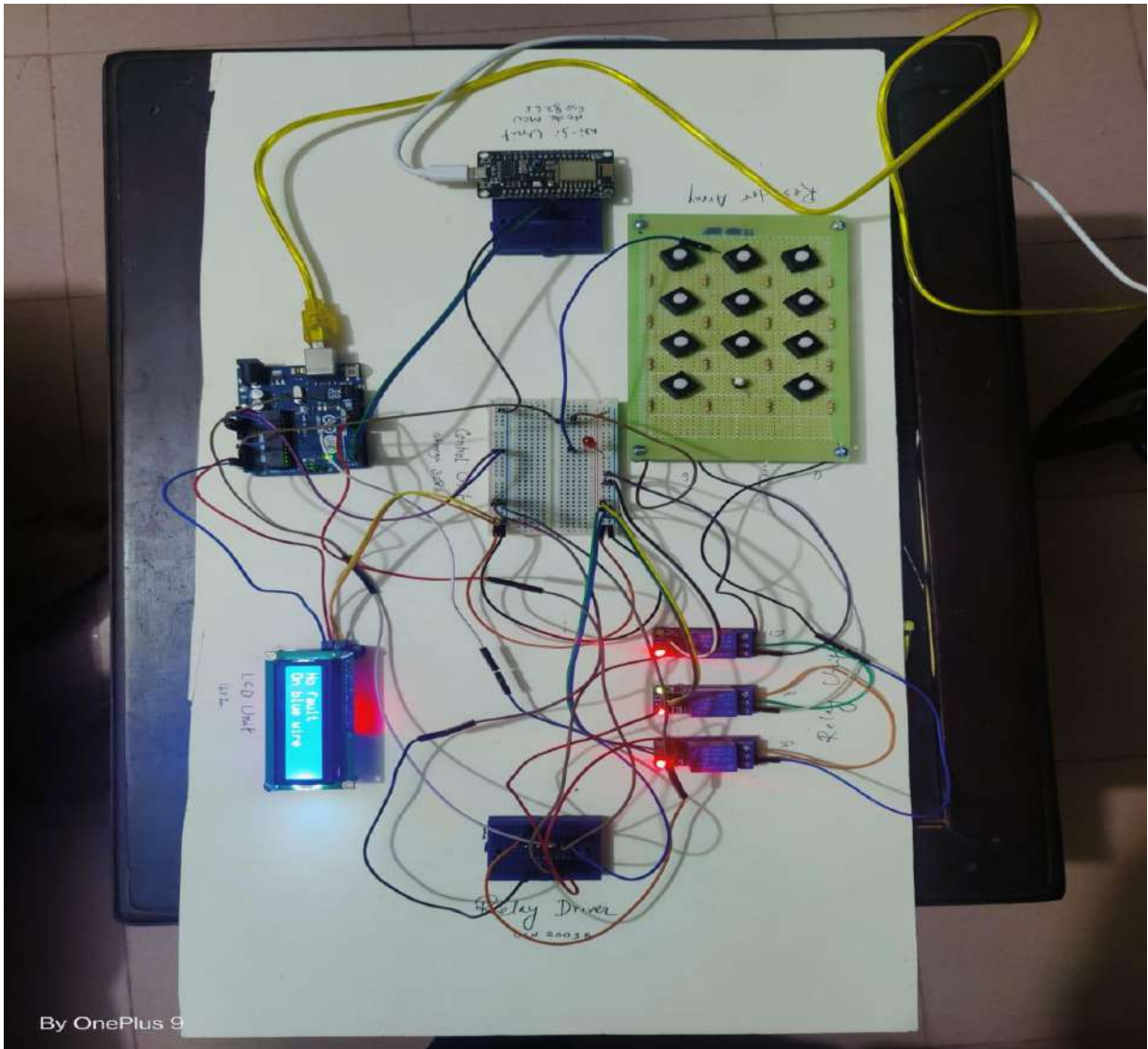

Fig 5.2: Circuit Diagram of the entire system.

In this system we have developed arduino based underground cable fault detection. We used 12vold dc output voltage. In relay module output we have used 12volt dc power supply. In arduino we have used 5volt stable voltage power supply. We passed around 3.3 to 4 volt to our resistance array in switching section. We measures voltage drop over resistor array. When switches is closed we counts remaining voltage after passing the resistors. As we see, mode the resistor have been passed the remaining voltage will decrease.

5.3 Circuit Diagram of the Entire System

Circuit diagram of the entire system is shown in the Fig 5.2,

In this circuit arduino is the heart of this system. It takes all the values from sensors. Getting those data it updates the value on LCD.

5.4 Entire System Prototype:

The prototype figure of entire system is shown below where all the components are clearly depicted. This system use ac power supply to run and the adaptor used as alternative power source. Power sensor, relay, ice, led all designed for Arduino based projects to control devices. Arduino used for machine mechanism and cooler fan are controlled by the use of the server. Here a prototype figure of the entire system is shown in the Figure 5.3

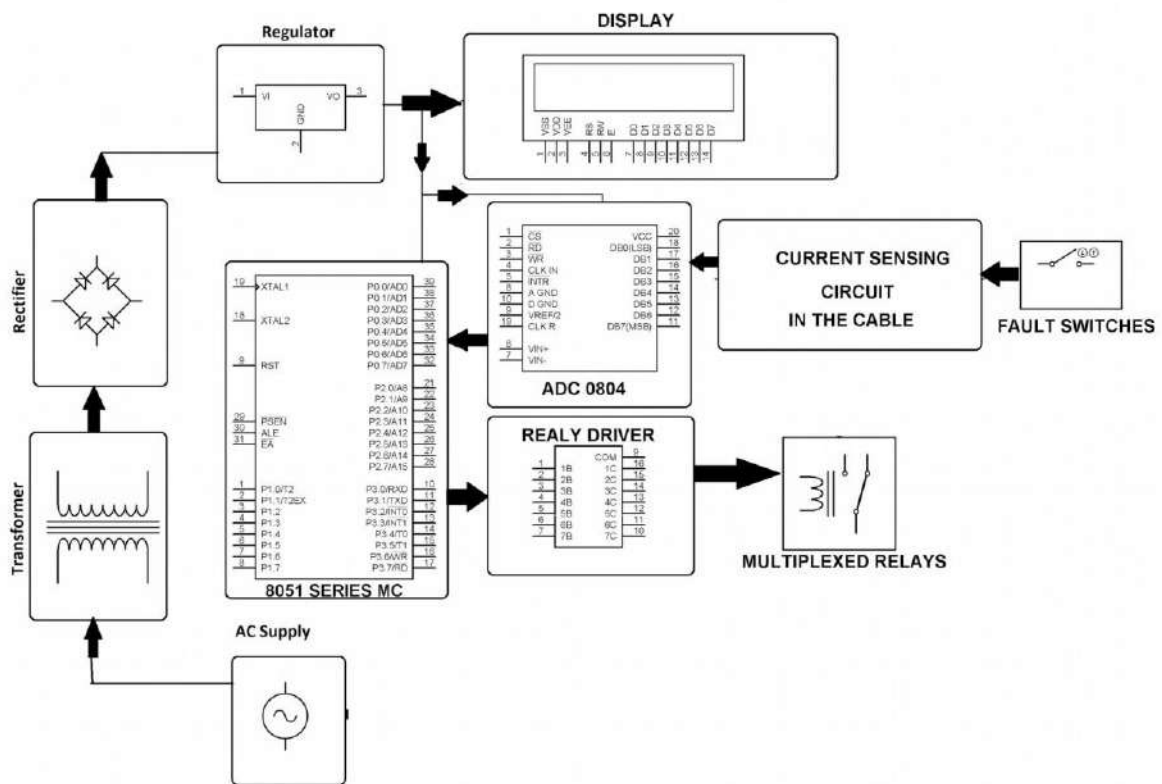

Fig: 5.3 Circuit block diagram [11]

CHAPTER 6

RESULT AND DISCUSSION

5.56.1 Introduction

In this chapter, the total output and result of this project is discussed. After completing of the entire system, our project has worked perfectly during experiment. We have done some experiments to determine the working capacity and efficiency of the project. We have been able to view the state of the appliances over arduino platform there are several pictures of output results shown in this chapter.

5.66.2 Project Outcome

In this session we will show the entire project outcomes. For getting the desired output at first we have to develop the system shown in the Figure 5.3 in the previous chapter. Cable fault detection system and observation system employs broadband connection, resulting in acceptable performance. Eventually, expected results were met. For establishing a proper system the appliances and the sensors placement is very much necessary. We used ULN2003A power measuring unit for getting voltage and current, used relay module to switching over resistor array, we used led units to show output on ULN2003A,



IoT Based Underground Cable Fault Detection System

Fault Type: open
Total Load: 100MW Power Supply
Area Observed: 10 KM
Checkpoint: 12
Fault location: 7

Refresh

Fig: 5.1: Power, voltage, current measurement on LCD

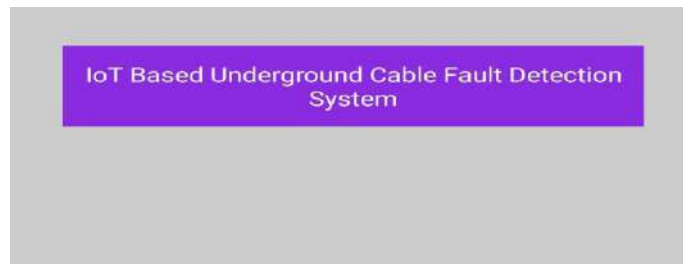
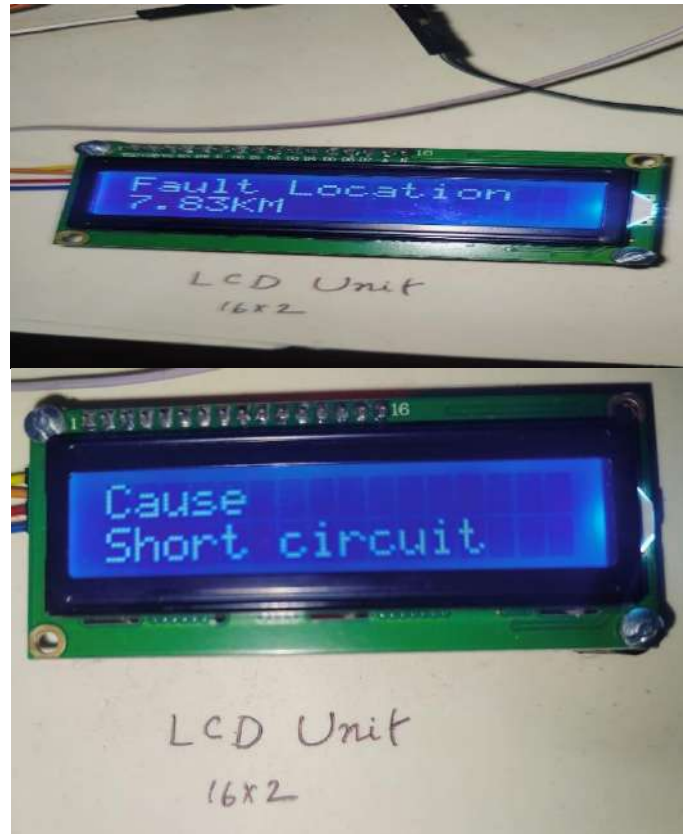

Fault Type: short
Total Load: 100MW Power Supply
Area Observed: 10 KM
Checkpoint: 12
Fault location: 7

Refresh

Fig: 5.1: Power, voltage, current measurement on LCD

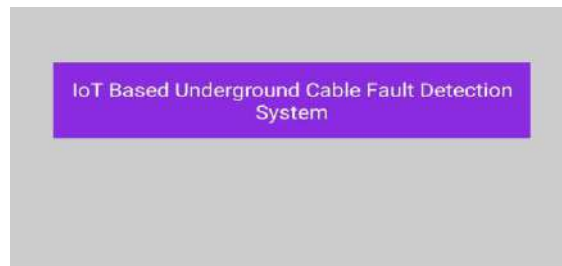
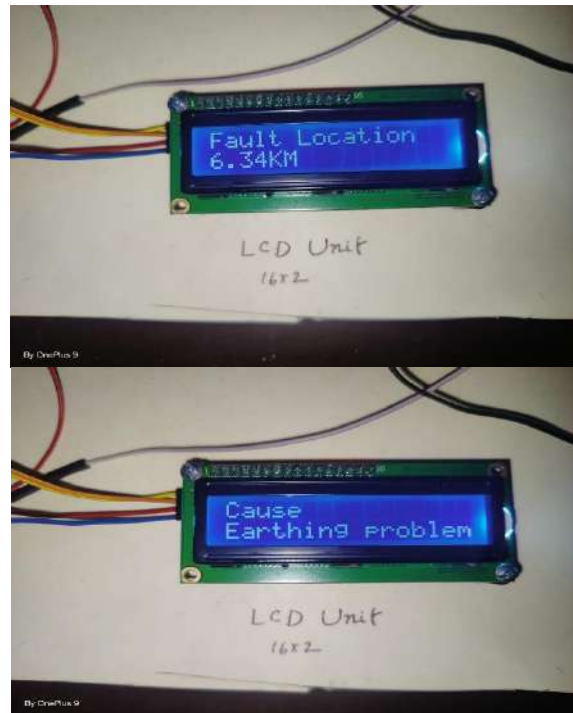

Fault Type: earthing
Total Load: 100MW Power Supply
Area Observed: 10 KM
Checkpoint: 12
Fault location: 6

Refresh

Fig: 5.1: Power, voltage, current measurement on LCD

5.7 Cost Analysis

Table 5.1 Cost analysis of the proposed UNDERGROUND CABLE FAULT DETECTION SYSTEM.

No	Name	Quantity	Price
1	Arduino	1	550/-
2	Relay module	3	150/- per
3	ULN2003A	1	30/-
4	16x2 Lcd display	1	150/-
5	I ² C	1	180/-
6	LED	5	2/- per
7	1k Resistor	19	1/- per

5.8 Discussion

Underground cables have been extensively used for power distribution networks over the years. This is because of their suitability for underground connections, better security from activities of vandals and thieves, and resistance to hazardous climatic conditions such as thunderstorms and whirlwind. They are cheap, easy to maintain and environmental friendly. They have reduced maintenance and operating costs such as lower storm restoration cost. Also, underground cables eliminate the menace of wind-related storm damage. They are not subjected to destruction caused by flooding which usually spoil and interrupt electric service. They ensure fewer transitory interruptions through tree falling on wires or electric poles falling down thereby improving public safety. Life-wire contact injuries is drastically reduced. It leads to the elimination of unattractive poles and wires on the streets thereby enhancing the visual range of the drivers and pedestrians on the streets.

Chapter 6

CONCLUSION

6.1 Introduction

It can be concluded that this system can be applied to every transmission lines to control the system far away from the power distribution plants. In this project we have designed and developed such a device or system by considering all previous drawbacks which provides continuous home monitoring system in a convenient way. The system is designed with medium cost instruments and locally available which makes it an easily obtainable product for the people of any level with electronic device.

7.2 Advantages & Application

- Our system is user friendly. Anyone can manage their system with our device.
- Anyone can monitor their system from LCD. So maybe some people will also want to implement it in their house also.
- Continuous monitor can overcome upcoming fault accident.
- Low cost installation.
- Uses both short circuit test and open circuit test to detect underground cable fault point detection.

6.2 Limitations

Through the automation system provides various automation in our regular life, but it also has some drawbacks. Here some drawbacks of this automation system given below:

1. Sometime switching error can be caused.
2. Wire fault type is not specified.

6.3 Future Work

1. In future it will be possible to use artificial intelligence in display system.
2. In future it will be possible to add alternative source in voltage /current measuring system.

REFERENCE

- [1] Snehal C. Kor 1 , Vivek D. Bavdhane , “Murray Loop Method for Underground Cable Fault Location Detection Using GSM”, Zeal College of Engineering and Research, Narhe, Pune, Maharashtra, India (2013)
- [2] Neha N. Badwaik 1, Achal J. Wakade 2, Sudha Shrikanth 3, “Underground Cable Fault Detection System by Using IoT”, Department of Electrical Engineering KDK College of Engineering, RTMNU, Nagpur, India. (28/2/2020)
- [3] Xiaohong Zhang;Xiongwei Jiang;Hengkun Xie_”The application of fiber optic distributed temperature sensor to fault detection of XLPE insulated underground cable”, IEEE xplore Xi'an, China, China conference(2002).
- [4] Arduino uno rev3, Available“ <https://store.arduino.cc/usa/arduino-uno-rev3> ”, [Acceced 2013]
- [5] Arduino uno pin configuration, Available on “<https://www.circuito.io/blog/arduino-uno-pinout/>” , Acceced on (2014)
- [6] Relay module,Available on “<https://www.indiamart.com/proddetail/5v-10a-relay-singlechannelrelaymodule-18033218333.html> ”, Accessed on (2007).
- [7] ULN2003A block diagram. Available on “<https://www.elprocus.com/relay-driver-circuit-using-uln2003/>”, Accessed on (2013)
- [8] 16X2 LCD, Available on“<https://moonelectronicssbd.com/shop/display/16x2-display-module/>”, Accessed on (2017).
- [9] I2c module, Available on “<https://www.electronics.com.bd/pcf8574-i2c-lcd-driver-arduino-parts-icmodule-sensor-arduino-transistor-resistor-capacitor-robotics-project-electronics-bangladesh>”, Accessed (2017)
- [10] Circuit diagram, Available on “<https://create.arduino.cc/projecthub/Jaymish1011/wire-fault-detectora2a0ef>”, Accessed on (3/11/2018)
- [11] Circui diagram, Available on “<https://www.elprocus.com/underground-cable-fault-distance-locatorcircuit/>”, Accessed on (2019)

APPENDIX

program of product

// include the library code:

```
#include <LiquidCrystal.h>
```

// initialize the library with the numbers of the interface pins

```
LiquidCrystal lcd(12, 11, 5, 4, 3, 2);
```

// define phase control pins

```
int phase[3] = {7, 8, 9};
```

```
//************************************************************************
```

```
int distance(int inputVoltage) { if (inputVoltage >= 890 &&
```

```
inputVoltage < 920) { return 8;
```

```
 }
```

```
 else if (inputVoltage >= 850 && inputVoltage < 890) {
```

```
return 6;
```

```
 }
```

```
 else if (inputVoltage >= 750 && inputVoltage < 850) {
```

```
return 4;
```

```
 }
```

```
 else if (inputVoltage >= 600 && inputVoltage < 750) {
```

```
return 2; }
```

```
 else return 0 ;
```

```
 }
```

```
//************************************************************************
```

```
void setup() {
```

```
 // set up the LCD's number of columns and rows:
```

```
lcd.begin(16, 2);
```

```

// set pin mode for phase relays
for (int j = 0; j < 3; j++) {
    pinMode(phase[j], OUTPUT);
}
} void loop() {
digitalWrite(phase[0], HIGH);
delay(500);
    int dist1 = distance(analogRead(A0));
if (dist1 == 0) {    lcd.setCursor(0, 0);
lcd.write("R: ");    lcd.setCursor(3, 0);
lcd.write("NF  ");
    } else {
lcd.setCursor(0, 0);
lcd.write("R: ");
lcd.setCursor(3, 0);
lcd.print(dist1);
lcd.setCursor(4, 0);
lcd.write(" KM");
    }
digitalWrite(phase[0], LOW);
//=====
digitalWrite(phase[1], HIGH);
delay(500);
    int dist2 = distance(analogRead(A0));
if (dist2 == 0) {    lcd.setCursor(8, 0);
lcd.write("Y: ");    lcd.setCursor(11,
0);
    lcd.write("NF  ");
    } else {
lcd.setCursor(8, 0);
lcd.write("Y: ");
lcd.setCursor(11, 0);
lcd.print(dist2);
lcd.setCursor(12, 0);
lcd.write(" KM");

```

```

}
digitalWrite(phase[1], LOW);
//=====
digitalWrite(phase[2], HIGH);
delay(500);
int dist3 = distance(analogRead(A0));
if (dist3 == 0) { lcd.setCursor(0, 1);
lcd.write("G: "); lcd.setCursor(3, 1);
lcd.write("NF ");
} else {
lcd.setCursor(0, 1);
lcd.write("G: ");
lcd.setCursor(3, 1);
lcd.print(dist3);
lcd.setCursor(4, 1);
lcd.write(" KM");
}
digitalWrite(phase[2], LOW);
}

```