

IoT Based weather monitoring with Android application

by liuc Central Library

Submission date: 26-Jan-2021 09:04PM (UTC+0300)

Submission ID: 1494806918

File name: IoT_Based_weather_monitoring_with_Android_application-2_2.docx (2.31M)

Word count: 5103

Character count: 27461

IOT BASED AIR QUALITY AND WEATHER MONITORING SYSTEM WITH ANDROID APPLICATION

by

DIPESH DAS

ATA ULLAH

³
BACHELOR OF SCIENCE IN ELECTRICAL AND ELECTRONIC
ENGINEERING



Department of Electrical and Electronic Engineering
INTERNATIONAL ISLAMIC UNIVERSITY CHITTAGONG

DECEMBER 2020

IOT BASED AIR QUALITY AND WEATHER MONITORING SYSTEM WITH ANDROID APPLICATION

by

DIPESH DAS

ATA ULLAH

3

A project

submitted as partial fulfillment of the requirement for the degree of

**BACHELOR OF SCIENCE IN ELECTRICAL AND ELECTRONIC
ENGINEERING**



Department of Electrical and Electronic Engineering
INTERNATIONAL ISLAMIC UNIVERSITY CHITTAGONG
December 2020

CERTIFICATE OF APPROVAL

A project entitled " **IoT Based Air Quality and Weather Monitoring System with Android Application** " is presented by **Dipesh Das**, bearing Matric ID. **ET151024**, **Ata Ullah**, bearing Matric ID. **ET151043** session of **Spring 2020**, to the Department of Electrical & Electronic Engineering (EEE), International Islamic University Chittagong (IIUC). In partial fulfillment of the criteria for the degree of Bachelor of Science in Engineering, it was approved as satisfactory and accepted for the review carried out on the 30th December 2020.



28.12.2020

Supervisor

Engr. Sk. Md. Golam Mostafa

Assistant Professor,

Department of Electrical and Electronic Engineering

International Islamic University Chittagong.

DECLARATION

It is mentioned hereby that we have carried out this work and that no piece of work found in this project has been submitted for the award of any degree or diploma somewhere else.

 28/12/20

Dipesh Das

 28/12/20

Ata Ullah

ACKNOWLEDGEMENT

In the name of Almighty, the most benevolent and gracious. First and foremost, we thank the Almighty who gave us strength and wisdom to think. For their love, moral and economic support, we thank our relatives. This has been a great support to us. We want to thank our distinguished Supervisor Engr. Sk. Mostafa Golam, Asst. Professor, EEE Department, IIUC, who gave us valuable advice and inspections during the work process. His invaluable contribution to the success of this project has been made by positive feedback and ideas during the experiment and project work. Last but not least, we appreciate the unconditional support and aid of our teachers, friends, classmates, seniors and laboratory assistants in every sector. We are lucky to have a nice human being like them next to us.

Authors

ABSTRACT

Air pollution is one of the worst environmental issues and has many detrimental effects on human health, the atmosphere and the climate. Air pollution Vehicles are the primary source of air pollution in all major urban areas, and manufacturing remains the second major source. The heavy use of cars has contributed to an important rise in atmospheric toxins. This leads to contamination of the atmosphere that affects human health. Some respiratory conditions such as asthma and skin rashes have also occurred. The air contaminants are invisible, resulting in people's negligence. Public appreciation is thus today's prime prerequisite. The advances in the Internet of Thing (IoT) sector have allowed the amount of harmful substances in air particles to be tracked and air quality can also be regulated. The goal is to build a device that can detect the amount of toxic particles in air with the sensor MQ135. A dedicated server is available to monitor air quality on the internet. An alarm is activated when harmful particles in the air such as CO (Carbon Monoxide). Air quality in PPM is shown on the web server if the toxicity in the air goes above the threshold value and the cleaning system is automatically turned on and the air is detoxified. The system can be deployed anywhere and some external devices can be enabled when pollution crosses the safe zone, for example by sending a notification to all the people there via an android application. Our work aims to provide indoor air quality monitoring and measurement with a low-cost budget method in real-time. Our project work is essential for all general users, who can easily reach the level of indoor air quality and can fully track indoor air quality.

Table of Contents

ACKNOWLEDGEMENT	v
ABSTRACT	vi
LIST OF FIGURES	ix
LIST OF TABLES	x
LIST OF ABBREVIATIONS	xi
CHAPTER 1: INTRODUCTION	1
1.1 Motivation	1
1.2 Objective	2
1.3 Thesis Outline	2
CHAPTER 2: LITERATURE REVIEW	3
CHAPTER 3: METHODOLOGY	5
3.1 Proposed Model block diagram	5
3.2 Flow Chart of Proposed System	6
3.3 Circuit Diagram of Proposed System	7
3.4 Proposed Model in Real Life	7
3.5 Components of the device	8
3.5.1 Arduino Uno R3	8
3.5.2 ESP 8266 Wi-Fi Module	9
3.5.3 DHT 22 Temperature and Humidity sensor	10
3.5.4 MQ-7 CO Gas sensor	11
3.5.5 MQ 135 Air quality sensor module	12
3.6 Software Requirements	12
3.7 Problem Formulation and Decision	12
3.8 Dataset	13
3.7.1 Dataset of US Embassy	14
3.7.2 Second Dataset of Our devices	14

3.8 Summary	15
CHAPTER 4: RESULT & DISCUSSION	16
4.1 Introduction	16
4.2 Dataset Description	16
4.2.1 Displaying data in LCD Display	16
4.2.2 Sending data to the cloud platform	17
4.3 Result	20
4.4 Cost Analysis	20
CHAPTER 5: CONCLUSION AND FUTURE WORKS	21
5.1 Conclusion	21
5.2 Future work	21
REFERENCES	22

List of Figures

14	7	Proposed model of the system	6
Fig. 3.1			
Fig. 3.2		Block diagram for proposed model of the system	6
Fig. 3.3	7	Flow Chart for proposed model of the system	7
Fig. 3.4		Circuit diagram for proposed model of the system	7
Fig. 3.5		Proposed Model in Real Life	7
Fig. 3.6		Arduino Uno	8
Fig. 3.7	44	ESP 8266 Wi-Fi Module	10
Fig. 3.8		DHT 22 Temperature and Humidity sensor	10
Fig. 3.9		MQ-7 CO Gas sensor	11
Fig. 3.10		M135 Air quality sensor module	12
Fig. 4.1		LCD Display View	16
Fig. 4.2		Mobile Application view	17
Fig. 4.3		Output of the device in the cloud platform	18

List of Tables

Table 3.1: AQI scale for continues concentration of CO	13
Table 3.2: US Embassy Dataset	14
Table 3.3: Our devices Dataset	14
Table 3.4: Cost Analysis of the Project	19

List of Abbreviation

LPG: Liquefied Petroleum Gas

SDG: Sustainable Development Goals

UN: United Nations

56

AQI: Air Quality Index

AQHI: Air Quality Health Index

GPRS: General Packet Radio Services

55

GUI: Graphical User Interface

GPIO: General-Purpose input/output

PCB: Printed circuit board

57

HTML: Hypertext Markup Language

PHP: Personal Home Page

API: Application Programming Interface

27

LDAP: Lightweight Directory Access Protocol

IMAP: Internet Message Access Protocol

SNMP: Simple Network Management Protocol

NNTP: Network News Transfer Protocol

HTTP: Hypertext Transfer Protocol

PPM: Parts Per Million

CHAPTER 1

INTRODUCTION

Based on current ⁸ daily newspapers and any other electronic or print media, devastating news spreads every day, people get sick and the climate changes are so bad for people to live. Everyone is suffering from the ⁶ curse of climate change from top to bottom. Air pollution is the main cause of climate change and human health. It has brought climate change, such as global warming, global dimming, rainfall, drought, acid rain, foggy weather, etc. ⁸ Living things on earth and under water suffers from many problems, such as a change in life due to a lack of adequate living facilities.

For every living thing, air is most useful. The main objective of this device was to determine air quality for humans and every other living thing on Earth in this serious problem. It is really important to know how healthy and how climate and weather have changed for air pollution and can preserve sound for our lives. This system makes it easy to know the air quality answers.

The system uses four main gas sensors that cause the most air pollution to know the best outcome of all air conditions. CO, Humidity is declared the key cause of air pollution and all are applied throughout the system. In order to quantify noise presence in the environment, a noise sensor is also added. The statistics were used for a server and Android program, as almost everyone now has an android computer and Internet access.

1.1 Motivation

No living thing without air will survive. Air is the key element for every life. In line with the UN (UN) SDGs, 17 targets are to make the planet a safe, balanced and normal ⁴⁶ place to live because there are many problems in human life at the moment. SDG says: "Sustainable consumption and production patterns; Taking urgently to combat climate change and its impacts; Preserving oceans, sea and marina resources sustainably, sustaining forestry management; combating desertification; halting and reverse lanes; and promoting good wellbeing of all ages; accessing sustainable, reliable, sustainable and up-to-date energy for all;"

² These are the main reason why the topic was chosen for the research purpose.

1.2Objective

To Design and implement IoT Based Air Quality and Weather Monitoring System with Android Application. The implemented project will perform the following task:

1. Combine advanced air quality sensing technology with the advanced capabilities for robust low-cost monitoring. Measure and display temperature and humidity level of the environment.
2. To know the quality of air over the web using a dedicated server.
3. Display the sensed data in user friendly Android Application.

1.3Thesis Outline

- Chapter 1 includes introduction, motivation and thesis outline.
- Chapter 2 outlines the previous works done in the field of air pollution.
- Chapter 3 describes the methodology of the proposed model including the specific components and their description.
- Chapter 4 describes result and discussion.
- Chapter 5 concludes the paper stating the challenges were found and the future work of the project.

CHAPTER 2

LITERATURE REVIEW

Every day pollution increases at an extraordinary speed. Air is the most important environmental factor that is potentially contaminated by airborne elements. The proposed system is a wireless sensor network to know the levels of air pollution and air quality that mainly track pollution in a smart city. It is a cheap, but effective, budget monitoring system.

In 2015, some previous initiatives, such as the Smart Vehicle Environment Surveillance System [1] were launched. It essentially defined the emission rate of polluting poisonous gasses. In order to recognize and affect harmful gasses, Industrial air pollution [2] protection and health monitoring system was implemented. In 2008, the system of low cost air quality [3] was addressed because the sensors and the system were at that time very costly. Air pollution could be monitored by the use of mobile GPRS [4]. Air quality awareness was implemented in metropolitan cities through the Wireless Sensor Network-based pollution surveillance system [5]. Even the Complex Method of Pollution Monitoring [6] has been used before.

By looking at the future reports, we may conclude that ozone pollution has risen alarmingly. The entire planet will face smooth and severe weather for the future if it is not stopped right away. More waste is involved, for example: water pollution, noise pollution, plastic pollution, soil contamination, but we can tell from future research that air pollution is a worst problem and this should be investigated in order to save the planet.

According to the WHO, air pollution is a significant threat to health and the environment from smog hanging over the city to smoke inside the building. Increased mortality due to stroke, heart attack, chronic obstructive pulmonary disease, lung cancer and acute respiratory infections are the cause of combined effects of outdoor and household ambient air pollution. More than 80 per cent of urban air pollution-controlled people are exposed to air quality levels above the 10 µg/m³ guideline, with low and medium-sized countries at the highest levels of exposure.

Vehicles, electricity generation, building heating systems, farming and biomass burning, and manufacturing are significant external sources of emissions. Furthermore, over 3 billion people around the world depend for domestic cooking, heating and lighting, smoke releases to homes and leaches of pollutants outside on pollutants and fuels (including biomass, carbon and kerosene).

Air pollution is caused by 9 out of 10 people worldwide. Green energy should be launched in order to avoid air pollution. WHO reports that atmosphere pollution caused some 4.2 million deaths alone in 2016, with the household air pollution caused at an estimated 3.8 million deaths over the same time by cooking contaminating fuels and technologies. The idea therefore was to build a device to let people know how much harmful air is inhaled. This method includes studies from past research about how necessary it is to address this topic. The key concept was to create a computer that is compact and simple to install. The usage and internet user of Android devices has significantly increased. For easy access for the users, both a website and the android application view the result of the device.

When measuring air, water and sound pollution in everyday life, it would be important for human health to measure pollution. Different forms of air pollution monitoring gas sensors are located at various points of the city to detect air pollution. The polluted area and the area containing harmful particles for humans will be the main priority. These sensors collect practical data on different gases (e.g., nitrogen dioxide (NO₂), carbon monoxide (CO), methane (CH₄) and humidity in real-time from different affected areas. It will also collect data on the sound level in the area. The proposed system mainly provides for the monitoring, by means of an application developed via Graphical User Interface (GUI), of air quality and of the pollution conditions of a smart city on a desktop and laptop computer which send signal when pollution exceeds appropriate standards.

CHAPTER 3

METHODOLOGY

This is the proposed device model. ⁶² Figure 3 demonstrates the operation of the whole system. The system block diagram illustrates how the system operates in a specific area. The system is optimized for environmental data and a standard base value is given. The system collects data and the output will be displayed based on the set values. The model ³ system is shown in Fig.3.1.



Fig. 3.1. Proposed model of the system [18].

3.1 Proposed Model block diagram

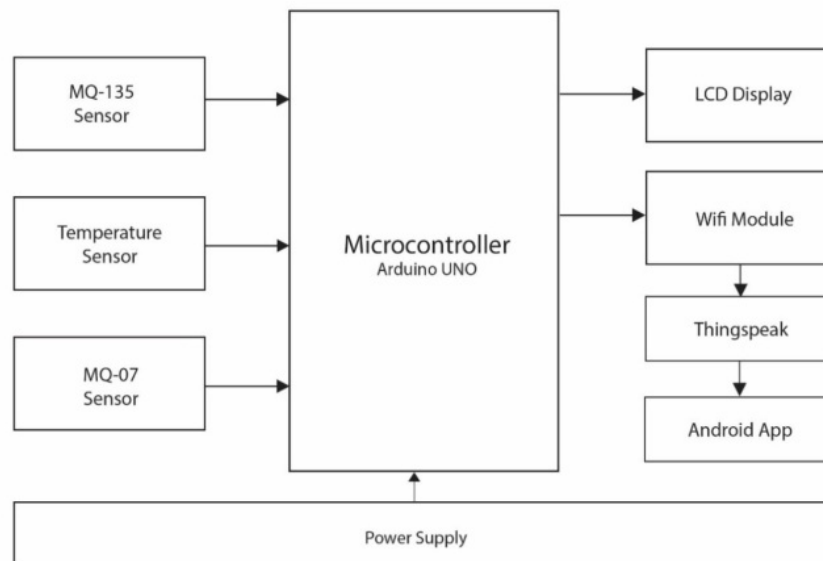

Fig. 3.2. Block diagram for proposed model of the system

43

The block diagram of proposed model of the system is shown in Fig.3.2. Here three sensors- air quality sensor (MQ 135), temperature and humidity sensor (DHT 22), CO gas sensor (MQ 7) is connected to microcontroller (Arduino Uno) as input and LCD display is connected to see the output of the project. A Wi-Fi module is also connected through which we can see the result in think speak web server or android application.

15

3.2 Flow Chart of Proposed System

The Fig.3.3 shows the flow chart of the proposed model system.

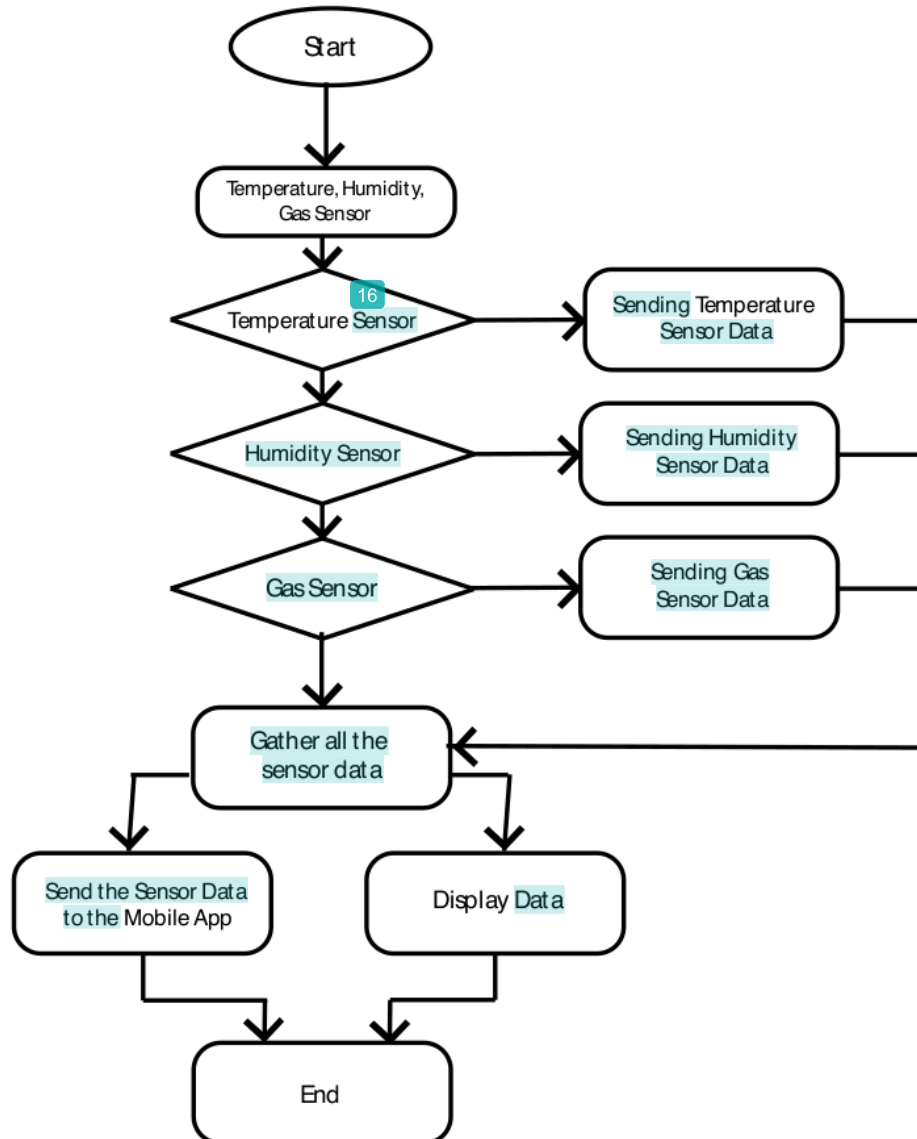

Fig. 3.3: Flow Chart for proposed model of the system

3.3 Circuit Diagram of Proposed System

The Fig.3.4 shows the Circuit Diagram of Proposed System.

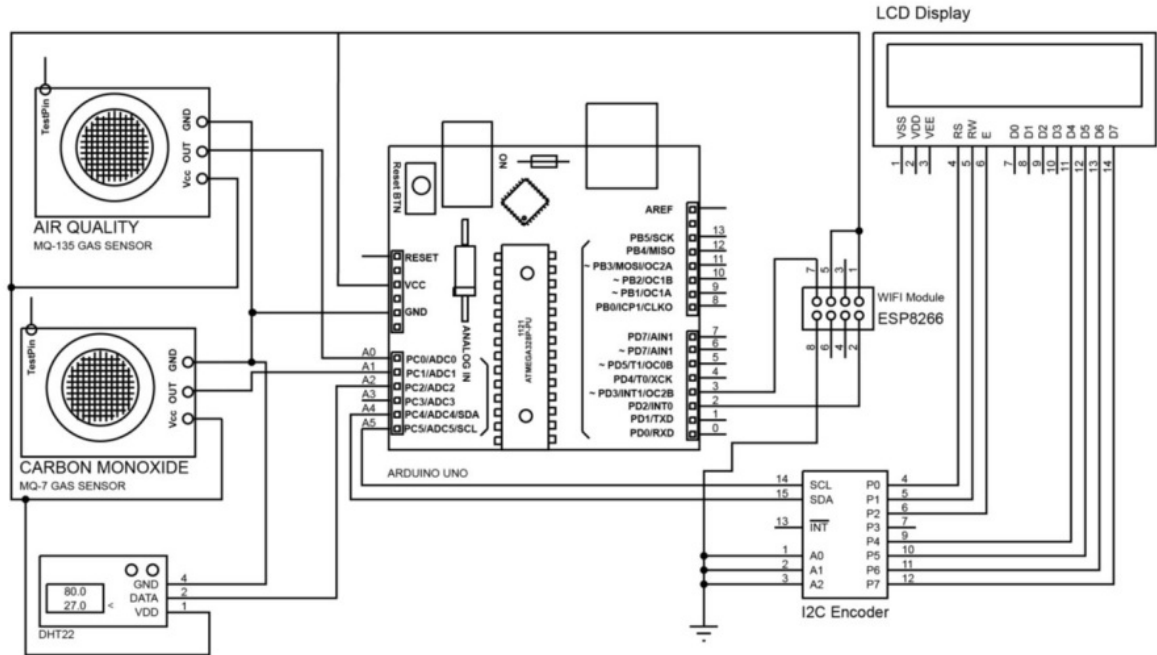

Fig. 3.4: Circuit diagram for proposed model of the system

3.4 Proposed Model in Real Life

The Fig.3.5 shows the Proposed Model in Real Life.

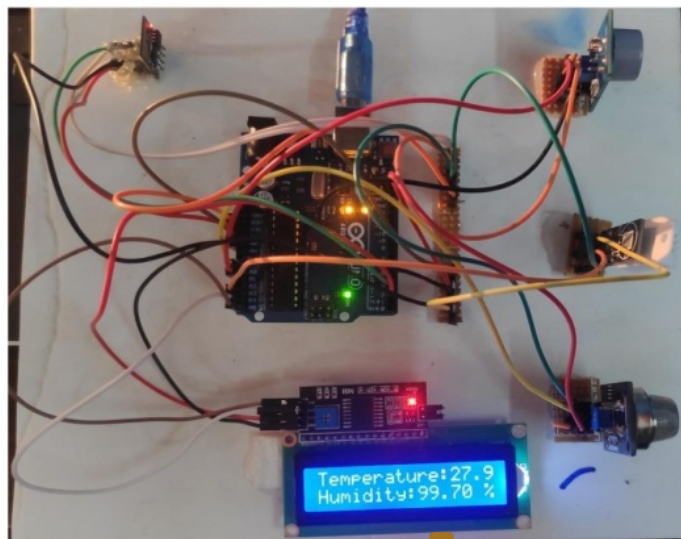

Fig. 3.5: Proposed Model in Real Life

3.5 Components of the Device

It is a device which takes data for our research purposes from the environment. The unit is constructed from different sensors and data is collected through environmental sensing. The sensors use raspberry pi to take analog data from the environment and then to the server where all data is saved to digitalize it. This device is consisting of the following components:

1. Arduino Uno R3
2. DHT 22 Temperature and Humidity sensor
3. MQ-7 CO Gas sensor
4. MQ 135 Air quality sensor module
5. ESP 8266 Wi-Fi Module
6. Wire
7. Breadboard
8. LCD Display

These components are briefly discussed in the following section:

3.5.1 Arduino Uno



Fig. 3.6. Arduino Uno [13].

Arduino Uno is an ATmega328P based microcontroller board. Fig.3.6 shows the one of Arduino. It has 14 digital input/output pins (6 of which can be used as PWM outputs), 6

analog inputs, a 16 MHz ceramic resonator (CSTCE16M0V53-R0), a USB connection, a power jack, an ICSP header and a reset button. It contains everything you need to support a microcontroller; simply connect it to a computer with a USB cable or power it with an AC-to-DC adapter or battery to get started. The Pin Function of Arduino Uno are given below:

¹¹ Microcontroller	: ATmega328
Operating Voltage	: 5 V
Input Voltage (recommended)	: 7-12 V
Input Voltage (limit)	: 6-20 V
Digital I/O Pins	: 14 (PWM Output - 6)
Analog Input Pins	: 6
DC Current per I/O Pin	: 40 mA
DC Current for 3.3V Pin	: 50 mA
Flash Memory	: 32 KB (for Bootloader - 0.5 KB)
SRAM	: 2 KB
EEPROM	: 1 KB
Clock Speed	: 16 MHz

3.5.2 ESP 8266 Wi-Fi Module

The ESP8266EX includes a ⁹ 32-bit Tensilica processor, regular digital peripheral interfaces, antenna switches, balun, power amplifier, amplifier, filters and power control modules. Thanks to its wide range of operating temperatures, it can operate reliably in industrial environments. The chip ⁹ delivers reliability, compactness and robustness with highly integrated chip features and limited external discreet component count. The ¹⁸ Fig. 3.7 shows ESP 8266 Wi-Fi Module.

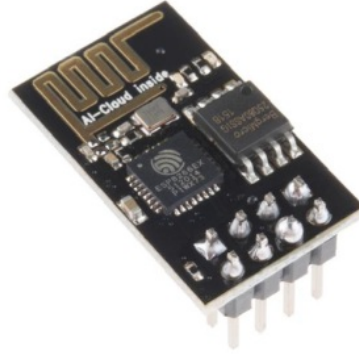

Fig. 3.7. ESP 8266 Wi-Fi Module [14].

9 The ESP8266EX microcontroller integrates a Tensilica L106 32-bit RISC processor, which achieves extra-low power consumption and reaches a maximum clock speed of 160 MHz. The Real-Time Operating System (RTOS) and Wi-Fi stack allow about 80% of the processing power to be available for user application programming and development.

3.5.3 DHT 22 Temperature and Humidity sensor

5 DHT22 Temperature & humidity Sensor displays a compound temperature & humidity with a digital signal output that is calibrated. 22 It offers high reliability and excellent long-term stability through the use of high-quality digital signal processing techniques and temperature & moisture sensing technologies. This sensor includes a high-performance 8-bit microcontroller with an excellent quality, a fast response, ant-interference capacity and cost-effectiveness, and includes a resistive moisture measurement component and an NTC temperature measurement component. 41 The Fig. 3.8 shows DHT 22 Temperature and Humidity sensor. 18



Fig. 3.8. DHT 22 Temperature and Humidity sensor [15].

Power is 3-5.5V DC from DHT22. If power is given to the sensor, no instructions will be sent to the sensor within a second to pass on the unstable status. Between VDD and GND for power filtration a condenser of 100 nF can be added.

3.5.4 MQ-7 CO Gas sensor



Fig. 3.9. MQ-7 CO Gas sensor [16].

The gas sensor of MQ7 is used for carbon monoxide detection. The **Fig. 3.9** displays a sensor MQ-7 CO Gas. Methane and other fuel vapor is also observed. It is cheap and suitable for various applications. Sensor prone to flame retardant gas and smoke. The sensor of smoke is powered by 5 volts. Smoke sensor reveals smoke output by the voltage, more smoke output. To change the sensitivity, a potentiometer is given. SnO₂ is the sensor that is used when the air is clean and of low conductivity. But when there's smoke, there's an analog smoke-based resistive output. There's a heater on the circuit. The heater is powered from the electricity supply by VCC and GND. A variable resistor is provided for the circuit. The strength throughout the pin will depend on the sensor's air smoke. **5** **if the content is** increased **and the voltage between the sensor and load resistor** is increased, resistance is lowered.

3.5.5 M135 Air quality sensor module



Fig. 3.10. M135 Air quality sensor module [17].

The Fig. 3.10 shows M135 Air quality sensor module. It is an unsafe gas detection component, suitable for ammonia, aromatic compounds, sulphur, benzene vapor, smoke and other gasses, gas sensitive element test. Sensor for air quality detects a variety of gases including NH₃, NO_x, alcohol, benzene, smoke and CO₂. Ideal for use with a simple drive and monitoring circuit in the office or factory.

3.6 Software Requirements

1. IDE
2. THINGSPEAK website
3. MIT App Inventor

3.7 Problem Formulation and Decision:

We have considered CO and H₂ to measure AQI. So we will only discuss CO and H₂ concentration [10]. Consider,

R_0 = Sensor resistance in fresh air.

R_s = Sensor resistance in displayed gases.

R_0 clean air factor = 10 (provided in the datasheet of the sensor). $p_{curve} = 3$, values for a specific gas obtained from the curve provided in the sensor datasheet.

Dividing the sensor resistance by R_0 clean air factor is calibrated the sensor. The gas percentage has to be calculated first to find the gas concentration.

$$\text{Gas percentage} = \left(\frac{\log(RsRoRatio)}{pcurve2} - pcurve1 + pcurve0 \right)^{10} \text{-----} (3.1)$$

To find the gas concentration, gas percentage need to be divided by the R_0 ,

$$\text{Gas concentration} = \frac{\text{gaspercentage}}{R_0} \text{-----} (3.2)$$

According to the gas concentration, AQI level needs to be measured.

Table 3.1: AQI scale for continues concentration of CO

CO	AQI	Category
1	11	Good
0	0.50	Good
1	11	Good
3	34	Good
5	56	Moderate
8	86	Moderate
10	109	Unhealthy
15	193	Unhealthy
2	23	Good

3.8 Dataset:

The following data was taken from the gas sensors which were attached with Arduino. We exported them in a particular format to an Excel Sheet. Those data will be used later to analyze. The more data we have, we can have more advantages to find more accurate results. And also, we can predict future air quality data.

3.8.1 Dataset of US Embassy:

Table 3.2: US Embassy Dataset [18].

CO (ppm)	Temperature (Celsius)	Humidity	AQI
1	31	61	Good
0	31	61	Good
1	32	63	Good
2	32	63	Good
3	31	61	Good
5	34	67	Moderate
8	34	67	Moderate
10	34	67	Unhealthy for Sensitive people
15	34	67	Unhealthy for Sensitive people
12	35	69	Unhealthy for Sensitive people

3.8.2 Second Dataset of Our devices:

Table 3.3: Our devices Dataset

CO (ppm)	Temperature (Celsius)	Humidity	AQI
1	31	61	Good
0	31	61	Good
1	32	63	Good
2	32	63	Good
0	31	61	Good
1	34	67	Good
1	34	67	Good
0	34	67	Good
2	34	67	Good

3.9 Summary

We have discussed our system device which was built by us, in this section. The circuit diagram and block diagram were shown in this section. We also introduced our formula which was used to detect gas percentage and gas concentration and described briefly.

RESULT AND DISCUSSION

4.1 Introduction

This chapter is all about our devices experiment and its results. We put our device in different situations to get data as much as possible.

4.2 Dataset Description

To measure and compare the performance of our device, we have used the US Embassy of Bangladesh dataset. This dataset consists of 2500 records and corresponding AQI scores. We have collected these datasets from their website. Data was taken in every hour of a day, every day of the month and every month of years.

3.2.1 Displaying data in LCD Display

Fig. 4.1(a), Fig. 4.1(b), and Fig. 4.1(c) show the output of air quality, CO, temperature and humidity in LCD Display respectively.



Fig. 4.1(a). LCD Display View (Air Quality)



Fig. 4.1(b). LCD Display View (CO)

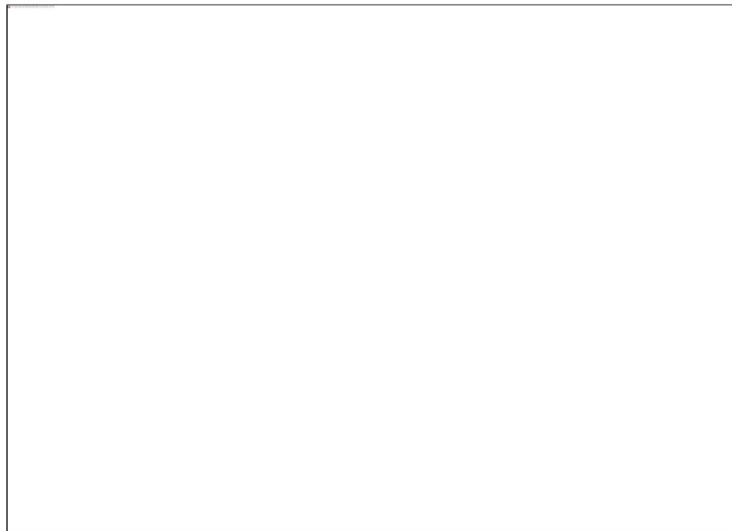

Fig. 4.1(c). LCD Display View (Temperature & Humidity)

4.2.2 Sending data to the cloud platform:

We have selected 5 data to send over to the cloud platform. The server takes 1 input from the Arduino every 10 seconds. We took 5 variables to store the data and send it to 5 different fields of the cloud channel. Fig. 4.2 shows the Mobile Application view of the system. Fig. 4.3(a), Fig. 4.3(b), Fig. 4.3(c), and Fig. 4.3(d) show the output of air quality, CO, temperature and humidity in the cloud platform respectively.

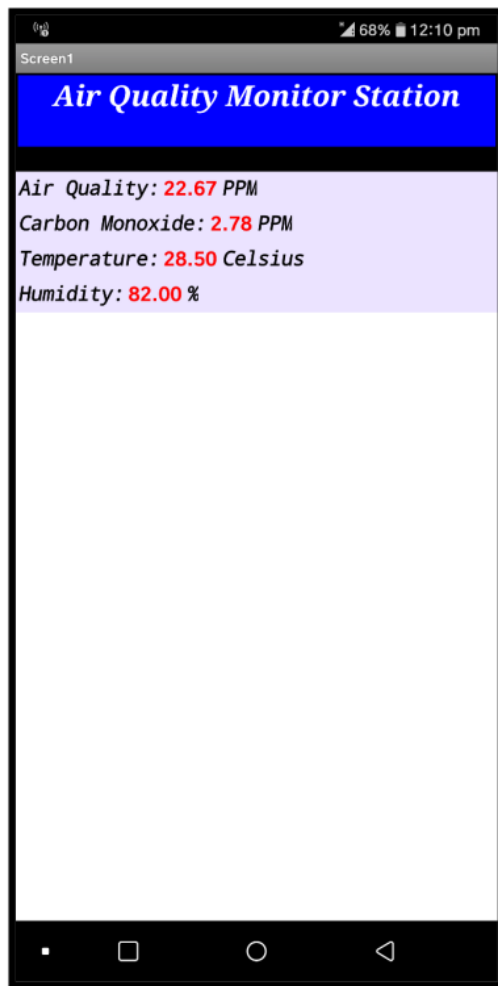

Fig. 4.2. Mobile Application view

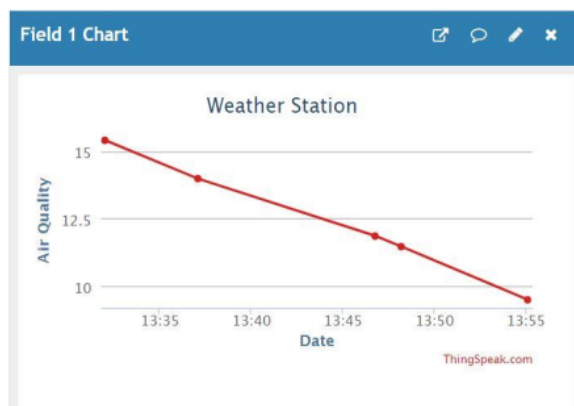

Fig. 4.3(a). Output of the device in the cloud platform (Air Quality)

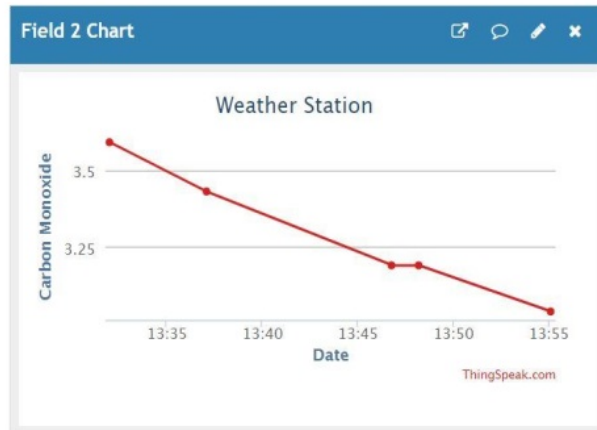

Fig. 4.3(b). Output of the device in the cloud platform (Carbon Monoxide)

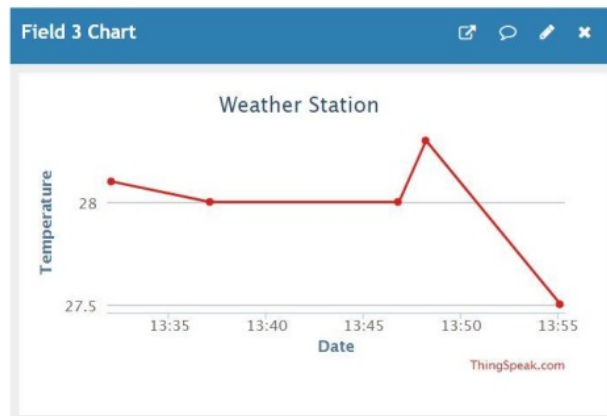

Fig. 4.3(c). Output of the device in the cloud platform (Temperature)

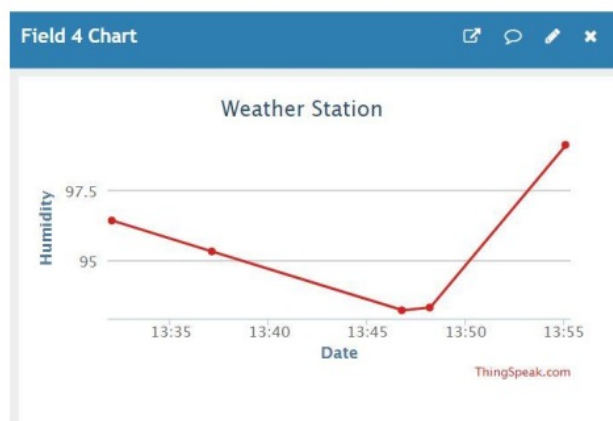

Fig. 4.3(d). Output of the device in the cloud platform (Humidity)

4.3 Result

25 Humans are very sensitive to humidity, as the skin relies on the air to get rid of moisture. If the air temperature is 24 C and the relative humidity is 100 percent, its feel like it's 27 C. 34 At room temperature of 28.5 C, the humidity rate we get is 82% which is slightly higher than due point. The standard rate of CO in air is 0 to 5 ppm. We have found 2.78 ppm. After the comparison, we found that our dataset has a higher accuracy than the US Embassy dataset.

4.4 Cost Analysis

Table: 3.4: Cost Analysis of the Project

Equipment name	Quantity	Price (BDT)
Arduino UNO	1	450
Esp8266	1	220
MQ-135	1	280
MQ-7	1	180
DHT-22	1	300
LCD Display	1	160
I2C	1	160
PCB Board	1	50
	Total	1800

CONCLUSION AND FUTURE WORKS**5.1 Conclusion:**

In this job, we find the intelligent way of monitoring the atmosphere and air in a low cost but effective and integrated system. Different sensor functions and working procedure were discussed in the proposed architecture. Here we also address the manner in which they operate, their features, their best use and processes for data collection and comparisons to standard basic data. The device for the control of air pollution was tested in various parts of the world to monitor gas levels. The sensor parameters were also forwarded to the data server. Our project system has shown that it is powerful and cheap and can be reliable to anyone with a few highly functioning sensors and its data is crucial to making some of the steps possible for better society so it will allow us to recognize the area in question so that we can take early measures to minimize harm for the next generation..

5.2 Future work:

In this project model, we didn't use any dust sensors and alarming devices to alert in danger. We will do that in future. In our model, we didn't make this for bigger houses like offices, schools. In that case we had to use wireless sensor network. But we had a lack of budget to build such devices. In future we will work along with radiation detection and machine learning algorithms for better future air quality detection.

REFERENCES

1. Jamila,M.S., Jamilb,M.A., Mazharc,A., Ikrama,A., Ahmeda, A., Munawa. “Smart Environment Monitoring System by employing Wireless Sensor Networks on Vehicles for Pollution Free Smart Cities”, 2015.
2. Leman,A.M., Omar, A.R., Jung,W., Yusof, M.Z.M. “The development of an industrial air pollution monitoring system for safety and health enhancement and a sustainable work environment using QFD approach”, 2010.
3. Kularatna,N.,“An Environmental Air Pollution Monitoring System Based on the IEEE 1451 Standard for Low Cost Requirements”, 2008.
4. Al-Ali, A.R.,“A Mobile GPRS-Sensors Array for Air Pollution Monitoring”, 2010.
5. Raipure,S., Mehetre,D.,“Wireless Sensor Network Based Pollution Monitoring System in Metropolitan Cities”, 2015.
6. Boscolo,A., Mangiavacchi,C.“Pollution Dynamic Monitoring System for City Air Quality Control”, 1998.
7. Jain,R., Palwa,K. “Air Pollution and Health.”, 2015
8. Bas, Ed, “Indoor Air Quality: Guide for Facility Managers”, 2d ed. New York: Marcel Dekker, 2004.
9. Moussiopoulos, Nicolas, ed., “Air Quality in Cities. New York: Springer”, 2003.
10. Harrap, D., “Air Quality Assessment and Management. London: Spon Press”, 2002.
11. Schwartz, Joel, “Air Quality in America. Washington, DC: AEI Press”, 2007.
12. Jong-Won Kwon,Yong-Man, Park,Sang-JunKoo,Hiesik Kim, “Design Of Air Pollution Monitoring System Using ZigBee Networks for Ubiquitous-City”, *International Conference on Convergence Information Technology*,2007.
13. “Arduino Uno”, Date of access: 21 Oct, 2020..retrived from: [Https://Store.Arduino.Cc/Usa/Arduino-Uno-Rev3](https://Store.Arduino.Cc/Usa/Arduino-Uno-Rev3)
14. “ESP 8266 Wi-Fi Module”, Date of access: 11 Oct, 2020.retrived from: [Https://Components101.Com/Wireless/Esp8266-Pinout-Configuration-Features-Datasheet](https://Components101.Com/Wireless/Esp8266-Pinout-Configuration-Features-Datasheet)
15. “DHT22 Temperature & Humidity Sensor”, Date of access: 2 Nov, 2020. retrived from: [Https://Components101.Com/Dht11-Temperature-Sensor](https://Components101.Com/Dht11-Temperature-Sensor)
16. “MQ-7 CO Gas sensor module”, Date of access: 7 Nov, 2020. retrived from: [Https://Components101.Com/Mq7-Gas-Sensor](https://Components101.Com/Mq7-Gas-Sensor)
17. “M135 Air quality sensor module”, Date of access: 21 Nov, 2020. retrived from: [Https://Components101.Com/Sensors/Mq135-Gas-Sensor-For-Air-Quality](https://Components101.Com/Sensors/Mq135-Gas-Sensor-For-Air-Quality)
18. “Dataset of US Embassy”, Date of access: 23 Nov, 2020. retrived from: [Https://Www.Sciencedirect.Com/Topics/Engineering/Home-Base-Station](https://Www.Sciencedirect.Com/Topics/Engineering/Home-Base-Station)

APPENDIX

Microcontroller Code of the proposed model:

```
24
#include <Wire.h>
#include <LiquidCrystal_I2C.h>
LiquidCrystal_I2C lcd(0x27, 2, 1, 0, 4, 5, 6, 7, 3, POSITIVE);
#include <SoftwareSerial.h>
SoftwareSerial ser(2, 3); // RX, TX

1
int gas_sensor = A0; //Sensor pin
float m = -0.3376; //Slope
float b = 0.7165; //Y-Intercept
float R0 = 15.52; //Sensor Resistance in fresh air from previous code

1
int CO_sensor = A1; //Sensor pin
float m1 = -0.6527; //Slope
float b1 = 1.30; //Y-Intercept
float R01 = 6.42; //Sensor Resistance

4
String apiKey = "GLH1QG0XZF2ZZQWP"; // Edit this API key according to your Account

36
#include <dht.h>
dht DHT;
#define DHT11_PIN A3
void setup() {

    // PC to Arduino Serial Monitor
23 Serial.begin(115200); // Arduino to ESP01 Communication
    lcd.begin(16, 2);
    lcd.backlight();
    lcd.setCursor(0, 0);
    lcd.print(" Air Quality & ");
    lcd.setCursor(0, 1);
    lcd.print("Weather Station");
    delay(2000);
4 lcd.clear();
    ser.begin(115200); // reset ESP8266
    ser.println("AT+RST"); // Resetting ESP8266
    char inv = "";
4 String cmd = "AT+CWJAP";
    String Host_Name = "Mi A1"; // Edit Host_Name
4 String Password = "tanmoy337"; // Edit
    cmd += "=";
    cmd += inv;
    cmd += Host_Name;
    cmd += inv;
    cmd += ",";
}
```

```

cmd+= inv;
cmd+= Password;
cmd+= inv;
17 Serial.println(cmd); // Connecting ESP8266 to your WiFi Router
pinMode(gas_sensor, INPUT);
pinMode(CO_sensor, INPUT);
pinMode(A3, INPUT); //For DHT Sensor
}
47
void loop() {
18 // Put your main code here, to run repeatedly:
float sensor_volt; //Define variable for sensor voltage
float RS_gas; //Define variable for sensor resistance
float ratio; //Define variable for ratio
float sensorValue = analogRead(gas_sensor); //Read analog values of sensor
sensor_volt = sensorValue*(5.0/1023.0); //Convert analog values to voltage
RS_gas = ((5.0*10.0)/sensor_volt)-10.0; //Get value of RS in a gas
ratio = RS_gas/R0; // Get ratio RS_gas/RS_air
double ppm_log = (log10(ratio)-b)/m; //Get ppm value in linear scale according to the the ratio value
double ppm = pow(10, ppm_log); //Convert ppm value to log scale
Serial.print("Air Quality = ");
81 Serial.println(ppm);
lcd.clear();
lcd.setCursor(0,0);
lcd.print(" Air Quality:");
lcd.print(ppm);
lcd.print(" ppm ");
delay(2000);
lcd.clear();
19
float sensor_volt1; //Define variable for sensor voltage
float RS_gas1; //Define variable for sensor resistance
float ratio1; //Define variable for ratio
float sensorValue1 = analogRead(CO_sensor); //Read analog values of sensor
sensor_volt1 = sensorValue1*(5.0/1023.0); //Convert analog values to voltage
RS_gas1 = ((5.0*10.0)/sensor_volt1)-10.0; //Get value of RS in a gas
ratio1 = RS_gas1/R01; // Get ratio RS_gas/RS_air
double ppm_log1 = (log10(ratio1)-b1)/m1; //Get ppm value in linear scale according to the the ratio value
double ppm1 = pow(10, ppm_log1); //Convert ppm value to log scale
32 Serial.print("CO PPM = ");
Serial.println(ppm1);

lcd.clear();
lcd.setCursor(0,0);
lcd.print("CO:");
lcd.print(ppm1);
lcd.print(" ppm ");
delay(2000);
lcd.clear();

```

```

intchk = DHT.read22(DHT11_PIN);
Serial.print("Temperature = ");
float temp = DHT.temperature;
Serial.println(temp);
float hum = DHT.humidity;
Serial.print("Humidity = ");
Serial.println(hum);

lcd.clear();
lcd.setCursor(0,0);
lcd.print("Temperature:");
lcd.print(temp);
lcd.print(" Celcius ");
lcd.setCursor(0,1);
lcd.print("Humidity:");
lcd.print(hum);
lcd.print(" % ");
delay(2000);
lcd.clear();

String state1=String(ppm);           // Converting them to string
String state2=String(ppm1);
String state3=String(temp);
String state4=String(hum);

String cmd = "AT+CIPSTART=\"TCP\","; // Establishing TCP connection
cmd += "184.106.153.149";           // api.thingspeak.com
cmd += "\",80\r\n\r\n";           // port 80

println(cmd);
Serial.println(cmd);

if (ser.find("Error")){

Serial.println("AT+CIPSTART error");
return;
}

String getStr = "GET /update?api_key="; // prepare GET string

getStr += apiKey;
getStr += "&field1=";
getStr += String(state1);           // Humidity Data
getStr += "&field2=";
getStr += String(state2);
getStr += "&field3=";
getStr += String(state3);
getStr += "&field4=";

```

```

getStr += String(state4);
getStr += "\r\n\r\n";

cmd = "AT+CIPSEND=";
cmd += String(getStr.length()); // Total Length of data

ser.println(cmd);
Serial.println(cmd);

if(ser.find(">")){

ser.print(getStr);
Serial.print(getStr);

}

else{

ser.println("AT+CIPCLOSE"); // closing connection

// alert user

Serial.println("AT+CIPCLOSE");

}

// Update after every 15 seconds

}

```

IoT Based weather monitoring with Android application

ORIGINALITY REPORT

40%

SIMILARITY INDEX

28%

INTERNET SOURCES

15%

PUBLICATIONS

35%

STUDENT PAPERS

PRIMARY SOURCES

1	jayconsystems.com Internet Source	4%
2	Submitted to Korea National University of Transportation Student Paper	3%
3	Submitted to University of Southern Mississippi Student Paper	3%
4	www.pantechsolutions.net Internet Source	2%
5	Submitted to Universiti Malaysia Perlis Student Paper	2%
6	Submitted to Canterbury Christ Church University Student Paper	2%
7	Submitted to University of Bedfordshire Student Paper	2%
8	Submitted to Nizwa College of Technology Student Paper	2%

9	esp8266-shop.com Internet Source	2%
10	Cheong Ghil Kim, Kuinam J. Kim. "Implementation of a cost-effective home lighting control system on embedded Linux with OpenWrt", Personal and Ubiquitous Computing, 2013 Publication	1%
11	Submitted to The Scientific & Technological Research Council of Turkey (TUBITAK) Student Paper	1%
12	Submitted to Ibra College of Technology Student Paper	1%
13	Submitted to Universiti Teknologi MARA Student Paper	1%
14	www.ent.ohiou.edu Internet Source	1%
15	Submitted to Universiti Teknikal Malaysia Melaka Student Paper	1%
16	link.springer.com Internet Source	1%
17	ethesis.nitrkl.ac.in Internet Source	1%

dspace.iiuc.ac.bd

18	Internet Source	1%
19	docplayer.net Internet Source	1%
20	Submitted to University of Leeds Student Paper	<1%
21	Submitted to Université Internationale de Rabat Student Paper	<1%
22	Submitted to National Institute of Technology, Rourkela Student Paper	<1%
23	circuitdigest.com Internet Source	<1%
24	repository.its.ac.id Internet Source	<1%
25	moldcurepro.com Internet Source	<1%
26	Submitted to Institute of Research & Postgraduate Studies, Universiti Kuala Lumpur Student Paper	<1%
27	www.tdcorrige.com Internet Source	<1%
28	Submitted to Kookmin University Student Paper	<1%

29	Submitted to Universiti Malaysia Terengganu UMT Student Paper	<1%
30	Submitted to BITS, Pilani-Dubai Student Paper	<1%
31	www.pakistantoday.com.pk Internet Source	<1%
32	www.hackster.io Internet Source	<1%
33	ijcsn.org Internet Source	<1%
34	www.brucefuels.com Internet Source	<1%
35	Submitted to The Hong Kong Polytechnic University Student Paper	<1%
36	lowpowerlab.com Internet Source	<1%
37	waseda.repo.nii.ac.jp Internet Source	<1%
38	pdfs.semanticscholar.org Internet Source	<1%
39	Submitted to Riga Technical University Student Paper	<1%

40	Submitted to Universiti Teknologi Malaysia Student Paper	<1%
41	Submitted to University of Pretoria Student Paper	<1%
42	Submitted to Universiti Malaysia Pahang Student Paper	<1%
43	Dilip Kumar, Kumar Gaurav Suman. "Noninvasive Temperature Measuring and Early Fault Detecting System for Manufacturing Industry", MAPAN, 2019 Publication	<1%
44	Submitted to University of Wales, Lampeter Student Paper	<1%
45	Andrzej Szczurek, Monika Maciejewska, Beata Bąk, Jakub Wilk, Jerzy Wilde, Maciej Siuda. "Detecting varroosis using a gas sensor system as a way to face the environmental threat", Science of The Total Environment, 2020 Publication	<1%
46	www.personalitydevelopmenttip.com Internet Source	<1%
47	vctec.co.kr Internet Source	<1%
48	www.circuitbasics.com Internet Source	<1%

49	repository.tudelft.nl Internet Source	<1%
50	dk.um.si Internet Source	<1%
51	wiki.foundationu.com Internet Source	<1%
52	"Inventive Communication and Computational Technologies", Springer Science and Business Media LLC, 2020 Publication	<1%
53	Submitted to Nanyang Technological University, Singapore Student Paper	<1%
54	"IoT based Real-time Air Quality Monitoring and Control System to Improve the Health and Safety of Industrial Workers", International Journal of Innovative Technology and Exploring Engineering, 2020 Publication	<1%
55	cronfa.swan.ac.uk Internet Source	<1%
56	www.fi.z-pdf.ru Internet Source	<1%
57	123dok.com Internet Source	<1%

58

www.ipsnews.net

Internet Source

<1%

59

utpedia.utp.edu.my

Internet Source

<1%

60

hdl.handle.net

Internet Source

<1%

61

S. Kwak, H.A. Toliyat. "A Hybrid Solution for Load-Commutated-Inverter-Fed Induction Motor Drives", IEEE Transactions on Industry Applications, 2005

Publication

<1%

62

"Proceedings of the Future Technologies Conference (FTC) 2020, Volume 3", Springer Science and Business Media LLC, 2021

Publication

<1%

63

sismik.stei.itb.ac.id

Internet Source

<1%

64

Rana Majumdar, Abhishek Srivastava, Devesh Tulsian, Ved P Mishra. "IOT based Street Light Controlling Mechanism", 2019 International Conference on Computational Intelligence and Knowledge Economy (ICCIKE), 2019

Publication

<1%

Exclude quotes Off

Exclude bibliography Off

Exclude matches Off