

International Islamic University Chittagong
 Department of Electrical and Electronic Engineering
 Final Assignment, Autumn 2019

Course Code: **EEE 1101**

Course Title: **Electrical Circuits I**

Full Marks: 40

Submission Time: Within 12 Hours from the scheduled starting time

[Answer all five questions given below. The figures in the right hand margin indicate full marks]

Set: OO

OO means last two digits of student ID are odd
 [Examples: ET193011, ET193213, ET193037 etc.]

- 1) a) Use source conversion technique to find the current in the resistor R_L . Replace the 6 V source by a 9 V source 4

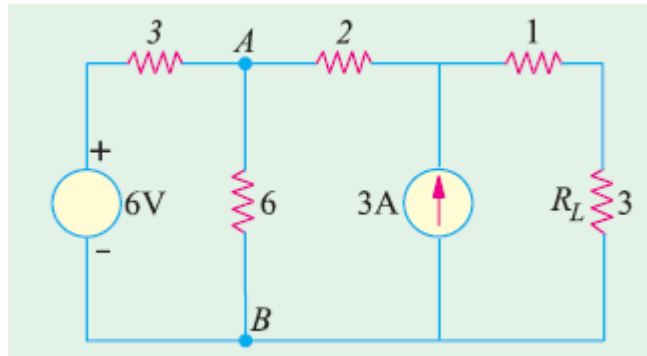

- b) Find V_{th} and R_{th} for the circuit given below between the terminals $a-b$. Replace the 12 V source by a 16 V source. 4

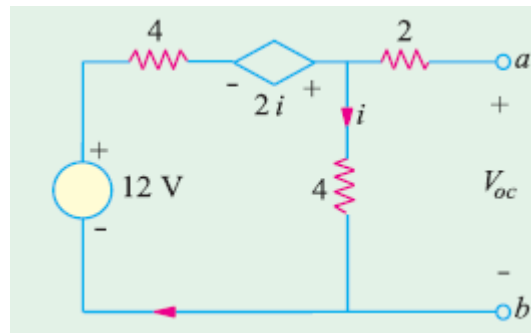

- 2) a) Find the Norton equivalent circuit for the network between $a-b$. Replace the 6 V source by a 4 V source. 4

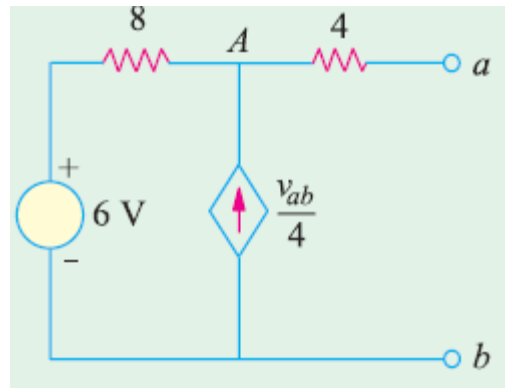

- b) In the circuit shown below obtain the condition for maximum power transfer to the load R_L and determine the maximum power consumed by R_L . Replace the 1 A current source by a 2 A current source. 4

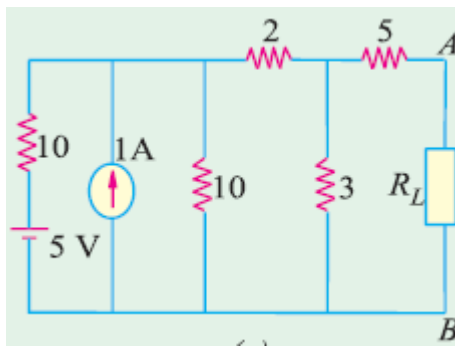

- 3) a) Three inductors L_1 , L_2 and L_3 are connected in parallel and the corresponding equivalent inductance is L_P . Derive the equation for L_P . 4
- b) For the R-C transient circuit given below replace the resistor R_1 by a $90\text{ k}\Omega$ resistor. 4
- (i) Find the mathematical expression for the transient behavior of the voltage across the capacitor of the circuit shown below if the switch is thrown into position 1 at $t = 0$ s.
- (ii) Repeat part (i) for i_C .
- (iii) Find the mathematical expression for the response of v_C and i_C if the switch is thrown into position 2 at $t = 30$ ms.
- (iv) Find the mathematical expression for the voltage v_C and current i_C if the switch is thrown into position 3 at $t = 48$ ms.
- (v) Plot the waveforms obtained in parts (i) through (iv) on the same time axis for the voltage v_C and current i_C using the defined polarity and current direction shown in the circuit.

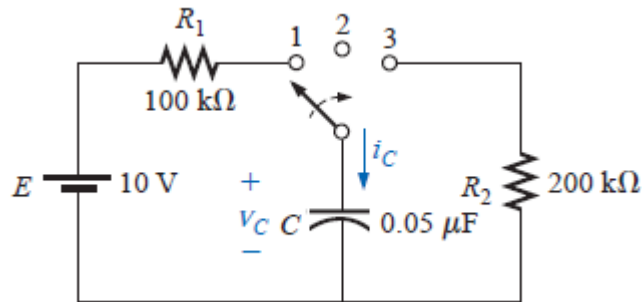

- 4) a) Classify materials with reference to relative magnetic permeability (μ_r). Derive the equation $B = \mu H$; Where the symbols have their usual meaning. 4
- b) For the magnetic circuit given below replace the given turns by $N = 390$ turns 4
- (i) Describe hysteresis loop with diagram. (ii) Determine the current I required to establish a flux of 4×10^{-4} Wb in the series magnetic circuit given below. (iii) Determine μ and μ_r for the material under these conditions. Use the B - H Plot of Magnetic Materials attached with the question.

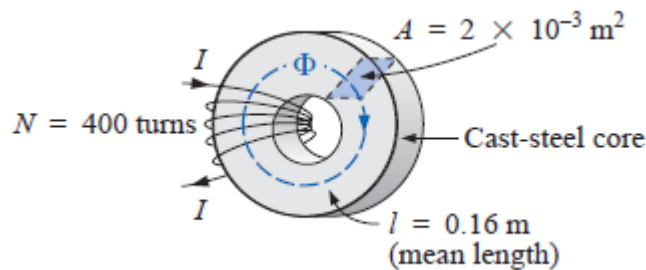

- 5) a) Define permeability, reluctance, magnetic field and flux density mentioning their units. 4
- b) Determine the secondary current I_2 for the transformer given below if the resultant clockwise flux in the core is 1.5×10^{-5} Wb. Replace N_1 by 55 turns. 4

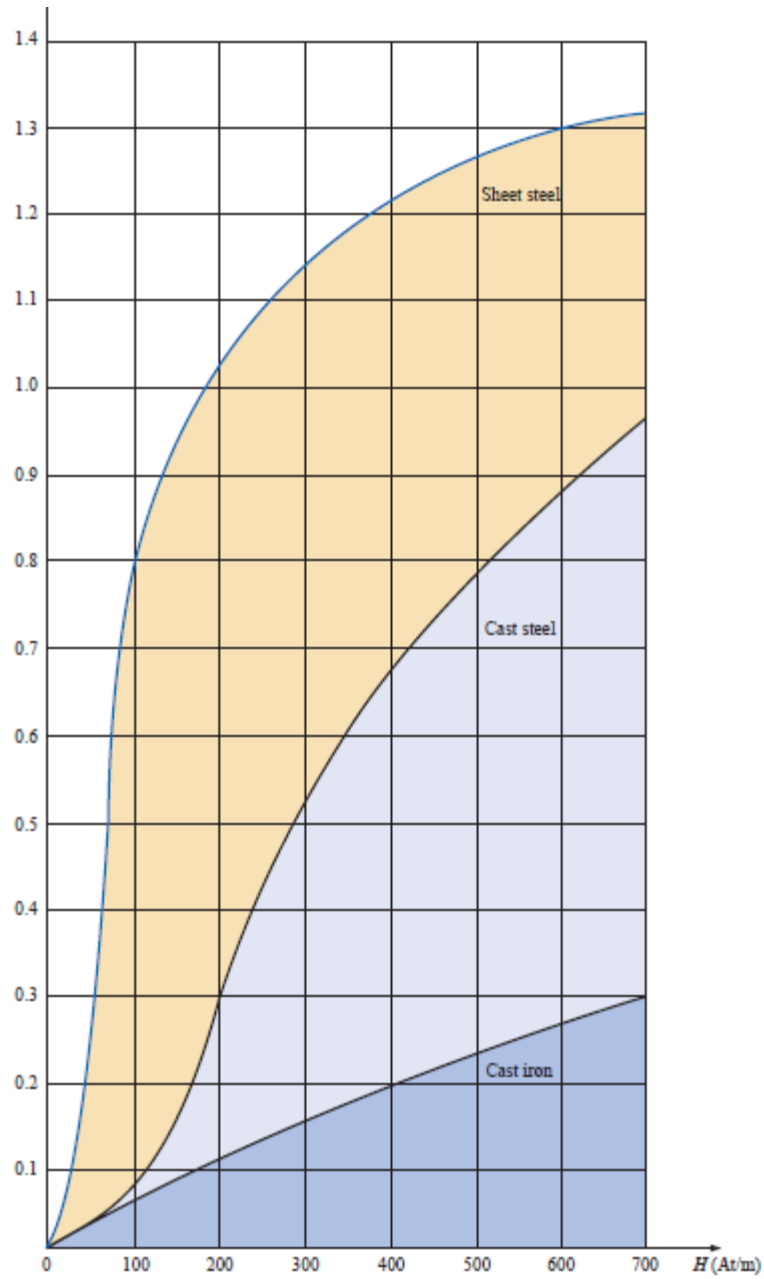
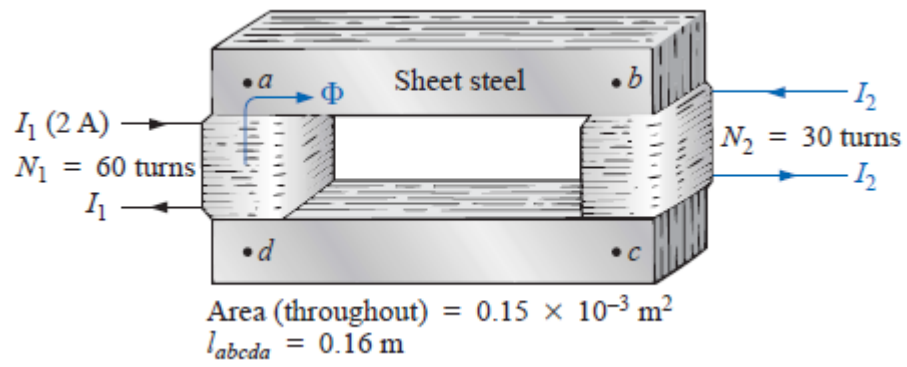

B-H Plot of Magnetic Materials