

# **Grid Integration of Renewable Energy: Sinusoidal Pulse Width Modulated Inverter**

by

Syed Golam Kibria, ET091021

Atiqul Islam, ET091031



**BACHELOR OF SCIENCE IN  
ELECTRICAL AND ELECTRONIC ENGINEERING**

Department of Electrical and Electronic Engineering  
International Islamic University Chittagong

June, 2013

# **Grid Integration of Renewable Energy: Sinusoidal Pulse Width Modulated Inverter**

by

Syed Golam Kibria, ET091021

Atiqul Islam, ET091031



Supervised by

**Mohammad Amin**

Assistant Professor

Department of Electrical & Electronic Engineering  
International Islamic University Chittagong

A thesis

Submitted as partial fulfillment for the degree of

**BACHELOR OF SCIENCE IN  
ELECTRICAL AND ELECTRONIC ENGINEERING**

Department of Electrical and Electronic Engineering  
International Islamic University Chittagong

June, 2013

## **CANDIDATES DECLARATION**

It is here by declaration that the work presented in this project report is done by us under the supervision of Engr. Mohammad Amin, Lecturer of the Department of Electronic Engineering, IIUC. The report or all the part related to this project is genuine. The project has not been published anywhere in full, or in part. All items and sub items that appear on the project are referenced, where needed. The project cannot be copied without the permission of the author. Also this project has not submitted earlier as an undergraduate project.

---

Syed Golam Kibria

---

Atiqul Islam

## CERTIFICATE OF APPROVAL

The thesis titled “Grid Integration of Renewable Energy: Sinusoidal Pulse Width Modulated Inverter”; Submitted by Syed Golam Kibria, ET091021 and Atiqul Islam, ET091031; Session 2009-2012; has been accepted as satisfactory in partial fulfillment of the requirement for the degree of B.Sc in Electrical and Electronic Engineering; on June, 2013.

### BOARD OF EXAMINERS

1. \_\_\_\_\_  
Mohammad Amin  
Assistant Professor, Dept. of EEE  
International Islamic University, Chittagong  
Supervisor
  
2. \_\_\_\_\_  
Dr. Md. Shakawat Zaman Sarker  
Head (In-Charge), Dept. of EEE  
International Islamic University, Chittagong  
Convener
  
3. \_\_\_\_\_  
Dr. Md. Delawer Hossain  
Professor, Faculty of Science  
International Islamic University, Chittagong  
Dean
  
4. \_\_\_\_\_  
Engr. Md. Razu Ahmed  
Associate Professor & Head, Dept. of ETE  
International Islamic University, Chittagong  
External

## **PREFACE**

This paper presents an illustration over the grid integration of renewable energy using sinusoidal pulse width modulated (spwm) inverter. Using basic concept of inverter, we inverted a given dc supply which we could get from renewable energy sources such as solar or wind energy etc. to three phase ac using a three phase spwm inverter. After inverting, the output ac is filtered to suppress the harmonics and then synchronized this filtered ac output voltage with the main supply ac voltage. When proper synchronization occurs, we can integrate this spwm to the grid and we can run the loads. We left an option for future work which is based on to provide a continuous supply from the spwm when the main supply voltage shuts down and spwm will generate its own reference signal for proper synchronization. We hope this project will be helpful to fulfill the present power crisis using natural resources.

---

## ▣ CONTENTS ▣

---

Acknowledgement	Page 1
Abstract	Page 2

Chapter1	INTRODUCTION	Page
1-1	Background	3
1-2	Objectives of this project	3
1-3	Advantages of this project	4
1-4	Renewable Energy Sources	4
1-5	Present status of Renewable Energy in Bangladesh	6
1-5-1	Solar Energy	6
1-5-2	Wind Energy	7
1-5-3	Biomass Energy	8
1-5-4	Hydropower	9
1.6	Block Diagram of Grid Integration of Renewable Energy	10
1.7	Terms of Synchronism	10

Chapter2	LITERATURE REVIEW	Page
2-1	DC-DC Converters	11
2-1-1	Principle of operation of Buck Converter	11
2-1-1-1	ON State operation of Buck Converter	12
2-1-1-2	OFF State operation of Buck Converter	13
2-1-1-3	MATLAB Simulation for Buck converter	13
2-1-2	Principle of operation of Boost Converters	14
2-1-2-1	ON State operation of Boost Converters	15
2-1-2-2	OFF State operation of Boost Converters	15
2-1-2-3	MATLAB Simulation for Boost converter	16
2-1-3	Operating Principle of Buck-Boost Converters	17
2-1-3-1	ON State Operation of Buck-Boost Converters	17
2-1-3-2	OFF State Operation of Buck-Boost Converters	18
2-1-3-3	MATLAB Simulation for Buck-Boost converter	18
2-1-4	Cúk Converter	19
2-1-4-1	On State Operation of Cúk Converter	20
2-1-4-2	Off State Operation of Cúk Converter	20
2-1-4-3	MATLAB Simulation for Cúk Converter	21
2-2	Rectifiers	22
2-2-1	Three-phase Uncontrolled Rectifiers	22
2-2-2	Three-phase Controlled Rectifiers	23
2-3	Voltage Source Inverters	23
2-3-1	Full-Bridge VSI	25
2-3-1-1	MATLAB Simulation for Full Bridge VSI	25

<b>Chapter3</b>	<b>SINUSOIDAL PULSE WIDTH MODULATION</b>	<b>Page</b>
3.1	Introduction	27
3.2	PWM & SPWM	27
3.3	Mathematical Modeling of SPWM Switching Scheme	30
3.4	Amplitude Modulation for SPWM ( $m_a < 1$ ) and over modulation	31
3.5	Bipolar Switching in SPWM	34
3.6	Unipolar Switching in SPWM	35
3.7	SPWM in Three Phase Voltage Source Inverter	37

<b>Chapter4</b>	<b>SIMULATIONS OF GRID INTEGRATION OF RENEWABLE ENERGY USING PWM INVERTER</b>	<b>Page</b>
4.1	System modeling of Grid Connection	39
4.2	Simulation Parameters	39
4.3	Pulse Width Modulation Generator Modeling	40
4.4	Simulation Results	40

<b>Chapter5</b>	<b>IMPLEMENTATION</b>	<b>Page</b>
5.1	Circuit Diagrams	44
5.2	Practical Implementation	47
5.3	Outputs of the Project	49

<b>Chapter6</b>	<b>CONCLUSION</b>	<b>Page</b>
6.1	Discussion on the output	52
6.2	Future Work	52
6.3	Limitations	53
6.4	Final comment	53

References	54
Appendix-I	56
Appendix-II	60
Appendix-III	61
Appendix-IV	63

## ▣ LIST OF FIGURES ▣

No.	Name	Page
Fig. 1.1	Monthly average solar radiation profile in Bangladesh <sup>[1]</sup>	6
Fig. 1.2	Distribution of SHSs in seven divisions of Bangladesh <sup>[14]</sup>	7
Fig. 1.3	Wind power density at different areas for different period <sup>[1]</sup>	8
Fig. 1.4	Rice production (Thousand Metric Ton) in Bangladesh in past 11 years <sup>[14]</sup>	8
Fig. 1.5	Schematic arrangement of grid connected PV system	10
Fig. 2.1	Buck Converter	12
Fig. 2.2	Output Voltage of Buck Converter	12
Fig. 2.3	ON State operation of Buck Converter <sup>[15]</sup>	13
Fig. 2.4	OFF State operation of Buck Converter <sup>[15]</sup>	13
Fig. 2.5	MATLAB Simulation for Buck Converter	14
Fig. 2.6	Output wave shapes for the simulation of buck converter in MATLAB	14
Fig. 2.7	Configuration of a Boost converter	15
Fig. 2.8	ON State operation of Boost Converter	15
Fig. 2.9	OFF State operation of Boost Converter	15
Fig. 2.10	Inductor Voltage for Boost converter	15
Fig. 2.11	MATLAB simulation for the Boost Converter	16
Fig. 2.12	Simulated out of the Boost Converter	17
Fig. 2.13	Schematic of a buck-boost converter <sup>[8]</sup>	17
Fig. 2.14	On state of Buck-Boost converter <sup>[8]</sup>	17
Fig. 2.15	Off state of Buck-Boost converter <sup>[8]</sup>	18
Fig. 2.16	Inductor voltage for buck-boost converter	18
Fig. 2.17	MATLAB Simulation for buck-boost converter	19
Fig. 2.18	Output for buck-boost converter	19
Fig. 2.19	Schematic of Cúk converter <sup>[8]</sup>	20
Fig. 2.20	On state of Cúk Converter <sup>[8]</sup>	20
Fig. 2.21	Off state of Cúk Converter <sup>[8]</sup>	20
Fig. 2.22	Output Inductor voltages for the Cúk Converter	20
Fig. 2.23	MATLAB Simulation for Cúk Converter	21
Fig. 2.24	Simulated waveforms for the Cúk Converter	21
Fig. 2.25	MATLAB Simulation for three phase controlled bridge rectifier	22
Fig. 2.26	Output voltage for diode bridge rectifier	22
Fig. 2.27	Controlled Bridge Rectifier Simulation	23
Fig. 2.28	Simulated output for controlled bridge rectifier with 45° firing angle	23
Fig. 2.29	The ac output voltage produced by the VSI of a standard ASD <sup>[9]</sup>	24
Fig. 2.30	Single-phase full-bridge VSI <sup>[7]</sup>	25
Fig. 2.31	MATLAB Simulation for single phase full bridge VSI	26
Fig. 2.32	Simulated output of the single phase full bridge VSI	26
Fig. 3.1	Basic block diagram of PWM	28
Fig. 3.2	Generation of PWM using comparator	28
Fig. 3.3	SPWM Topology	29
Fig. 3.4	Sinusoidal Pulse Width Modulation Technique <sup>[8]</sup>	30

Fig. 3.5	Single phase, single legged PWM Inverter	31
Fig. 3.6	Result of over modulation	32
Fig. 3.7	Harmonics spectrum of PWM when $m_a = 0.8^{[8]}$	32
Fig. 3.8	Harmonics spectrum of PWM when $m_a = 2.5^{[8]}$	33
Fig. 3.9	Control of Voltage by varying $m_a^{[8]}$	33
Fig. 3.10	SPWM Inverter (Full Bridge)	34
Fig. 3.11	SPWM with bipolar switching <sup>[8]</sup>	35
Fig. 3.12	SPWM with unipolar switching <sup>[8]</sup>	36
Fig. 3.13	Circuit diagram of Three Phase SPWM VSI	37
Fig. 3.14	Output wave shapes for the SPWM in three phase VSI <sup>[8]</sup>	38
Fig. 4.1	Simulation of Grid Integration of PWM inverted DC source	39
Fig. 4.2	PWM generation model	40
Fig. 4.3	PWM inverted output	41
Fig. 4.4	Line to line voltage $V_{AB}$ , after filtering	41
Fig. 4.5	Grid integrated line voltages $V_{ab}$ , $V_{bc}$ & $V_{ca}$	42
Fig. 4.6	Line currents for the system	42
Fig. 4.7	Synchronized output 3phase voltages	43
Fig. 5.1	Circuit Diagram of the SMPS, zero crossing detection and microcontroller circuit	44
Fig. 5.2	Driver IC and PULSE amplification circuit	45
Fig. 5.3	Serial port LCD display circuit	46
Fig. 5.4	3D view of the whole system	47
Fig. 5.5	Arrangement of the whole system	47
Fig. 5.6	SMPS Circuit	48
Fig. 5.7	Driving Circuit	48
Fig. 5.8	Switching Board and LCD display	48
Fig. 5.9	Inverter Legs and step up transformer	49
Fig. 5.10	SPWM Inverter Output	49
Fig. 5.11	Line Voltage Wave shape	50
Fig. 5.12	Synchronized Output	50
Fig. 5.13	SPWM output	51

---

**▣ LIST OF TABLES ▣**

---

<b>No.</b>	<b>Name</b>	<b>Page</b>
Table 1.1	Wind turbine installations in Bangladesh by different organizations <sup>[3]</sup>	7
Table 2.1	Circuit Parameters Data of Buck Converter for MATLAB Simulation	13
Table 2.2	Circuit Parameters Data of Boost Converter for MATLAB Simulation	16
Table 2.3	Circuit Parameters Data of Buck-Boost Converter for MATLAB Simulation	18
Table 2.4	Circuit Parameters Data of Cúk Converter for MATLAB Simulation	21
Table 2.5	Switch states for a full-bridge single-phase VSI	25
Table 2.6	Circuit Parameters Data of full bridge VSI for MATLAB Simulation	26
Table 3.1	Switching states of the unipolar PWM and the corresponding voltage levels.	37
Table 4.1	Simulation parameters of SPWM Inverter	40

## ACKNOWLEDGEMENT

Firstly we express our gratefulness to almighty Allah as we have completed our project successfully by His mercy.

For this project paper, we would like to express our adorable respect to our project supervisor Mohammad Amin for his enormous support and careful guidance. Without his guidance it was almost impossible to carry out with the project work. He was very helpful and ever affectionate to endure the mistakes we had committed in the project and always encouraged us by correcting our wrong proceedings. This project was not an easy one to carry on because of the unavailability of the theoretical materials. It is only the endless support offered by him that enabled us to complete this devoted task.

We would also like to thank all the teachers of the department of Electrical & Electronics Engineering of International Islamic University Chittagong for their day to day counseling, mentoring and sharing their experience, which made us progressive and enlightened. They were always been our mentors to show us right way and their suggestions and technical help was the blessings for our project work.

Thanks to all for your guidance and patronage.

**Author**

Syed Golam Kibria  
Atiqul Islam

## ABSTRACT

Mobilizing and generating affordable as well as environment friendly energy resources is one of the key challengers for any nation in today's world. Today the top priority for Bangladesh is Energy and Power generation. Presently, out of around 161 million populations, only 40-41% has access to electricity. At least to bring the populations into the facility of electricity access as much as possible within the limited resources, we can utilize the natural resources to fulfill this expectation. Using solar or wind energy in association with the power electronics devices, we can supply the electricity to the consumers within their ability and we will be able to minimize the power problem as possible. Pulse Width Modulated (PWM) inverter is the combination of power electronics devices which reduces the major crisis of costs, where costs are the big issue for developing country like Bangladesh. Now-a-days, the integrated circuits (IC) are so reliable and cheap that make the carrying and inverting or converting elements easiest than the bulky and costly instruments used in the conventional power supply system. We expect that the grid integration of the renewable energy resources using pwm inverter may cause a tremendous remark in fulfilling the lack of power utilization across the world.

---

**Chapter 1****INTRODUCTION**

---

In this chapter, we will focus on the following points respectively:

- Background.
- Objectives of this project.
- Advantages of this project.
- Renewable energy sources.
- Present status of renewable energy in Bangladesh.
- Schematic arrangement of grid integration of renewable energy.

**1-1 Background**

---

Now-a-days, the use of electricity or power has become so wide in every fields of the world. With the increase of population around the world, the demand is also increased.

But within the limited resources, the fulfill of this demand is quiet impossible although the demand is fulfilled as much as possible using the blessing of modern technology such as power electronics in association with the renewable resources existing in the nature.

With respect to Bangladesh, the demand of power is very high, but unfortunately due to the lack of proper use of the resources or the lack of relevant resources and the lack of proper application of power electronics field, the demand still remains unfulfilled with respect to the large amount of increasing population.

To overcome the existing problems regarding the electric power in Bangladesh as much as possible, this project is built to meet the problem accompanied with the existing resources. To implement the project, the power electronics device such as three phase PWM (Pulse Width Modulation) inverter is implemented in association with IGBT (Insulated Gate Bipolar Transistor), diodes, capacitors etc. The natural resource utilization process such as Wind turbine or Solar panel consists the variable DC power is converted to fixed DC through a converter and the fixed DC power is then inverted to AC power through a three phase inverter accompanied with PWM and the output AC is integrated to the grid through the synchronizer. In this project, PIC18F4431 microcontroller IC is used using respective program to provide the required pulse to each MOSFET devices for conduction.

---

## 1-2 Objectives of this project

---

- To implement the PWM inverter module for grid integration.
- To provide the microcontroller program for the conduction of IGBTs.
- To determine zero crossing of the circuit.
- To synchronize the output AC power of inverter with the grid.
- To integrate the grid with the output AC of the inverter after proper synchronization.

---

## 1-3 Advantages of this project

---

- **Energy security:** It reduces or eliminates the need of imported energy sources which criticizes to the increased energy security.
- **Enhanced reliability:** Reducing the need for imported fuel and moving some generation closer to the loads they serve, can improve energy system reliability.
- **Financial opportunities:** By using the more energy sources which is not associated with the market fluctuations, we can reduce the long term energy costs to the consumer.
- **Reduce the cost:** The low cost of the power electronics devices reduce an amount of cost rather than three phase AC transmission system.
- **Easy implementation:** The implementation of this project is reliable and can be easily carried out from one station to other.

---

## 1-4 Renewable Energy Sources

---

Many nations utilize their natural resources such as coal, oil and natural gas to supply most of their energy needs, but reliance on fossil fuels arise a big problem. Fossil fuels are a finite resource. Eventually, the world will run out of fossil fuels, or it will become too expensive to utilize in future those that remain. Fossil fuels also cause air, water and soil pollution and produce greenhouse gases that contribute to global warming.

Renewable energy resources such as wind, solar, hydropower, ocean energy etc. offer clean alternatives to fossil fuels. They produce little or no pollution or greenhouse gases and they will never run out.

- **Solar Energy:** The sun is our most powerful source of energy. Sunlight or solar energy can be used for heating, lighting and cooling homes and other buildings, generating electricity and a variety of industrial processes. Most forms of renewable energy come either directly or indirectly from the sun. Solar panel or photovoltaic cell is used to produce the electricity using the energy coming from sun.
- **Wind Energy:** The energy of wind is used for the centuries to sail the ships and drive the windmills that grind grain. Today, wind energy is captured by wind turbine and used to generate electricity.
- **Hydropower:** Water flowing downstream is another form of powerful source. Water is a renewable resource, constantly recharged by the global cycle of evaporation. Flowing water can be used to power the water wheels that drive the mechanical processes. Thereby captured by the turbines and generators, the energy of flowing water can be used to generate electricity.
- **Ocean Energy:** The Ocean provides several forms of renewable energy and each one is driven by different forces. Energy from ocean waves and tides can be utilized to generate electricity and ocean thermal energy, from the heat stored in sea water, can also be converted to electricity. Using current technologies, most ocean energy is not cost effective compared to other renewable energy resources, but the ocean is the most important potential energy source for future.
- **Geothermal Energy:** The heat inside the earth produces steam and hot water that can be used to power generators and produce electricity, or for other applications such as home heating and power generation for industry.
- **Biomass energy:** Biomass is an important source of energy ever since people first began burning wood to cook food. Wood is still the most common source of biomass energy, but other sources of biomass energy include crops, grasses and other plants, agricultural and forestry wastes, organic components from municipal and industrial wastes. Biomass can be used to produce electricity and as fuel for transportation, or to manufacture products that would require the use of non-renewable fossil fuels.

## 1-5 Present status of Renewable Energy in Bangladesh

Now, here we are going to discuss about the present condition of renewable energies in Bangladesh which will indicate the probability of this sector in our country. <sup>[1]</sup>

### 1-5-1 Solar Energy

Solar radiation varies from season to season in Bangladesh. So we might not get the same solar energy all the time. In the Fig. 1.1 the monthly average solar radiation pattern is shown.

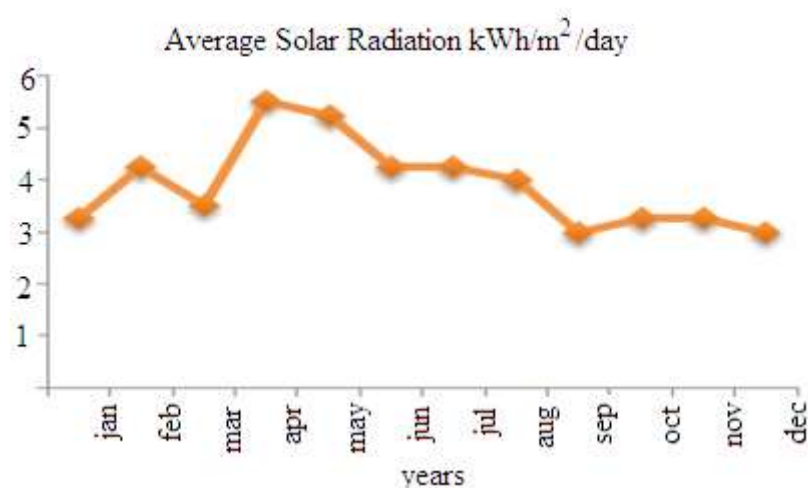

Fig. 1.1: Monthly average solar radiation profile in Bangladesh <sup>[1]</sup>

Daily average solar radiation varies between 4 to 6.5 KWh per square meter. Maximum amount of radiation are available in month of March-April and minimum in December-January. According to IDCOL (Infrastructure Development Company Limited), the total capacity of solar energy based installations in Bangladesh appears to be 20.75 MW. The amount is significant in considering the upward trend of the number of SHSs (Solar Home System) installations in country. <sup>[2]</sup>

The Fig. 1.2 shows the approximate division wise SHSs (Solar Home System) installation. This Figure illustrates that the distribution of the SHSs is highest in Dhaka whereas lowest in the newly formed district Rangpur.

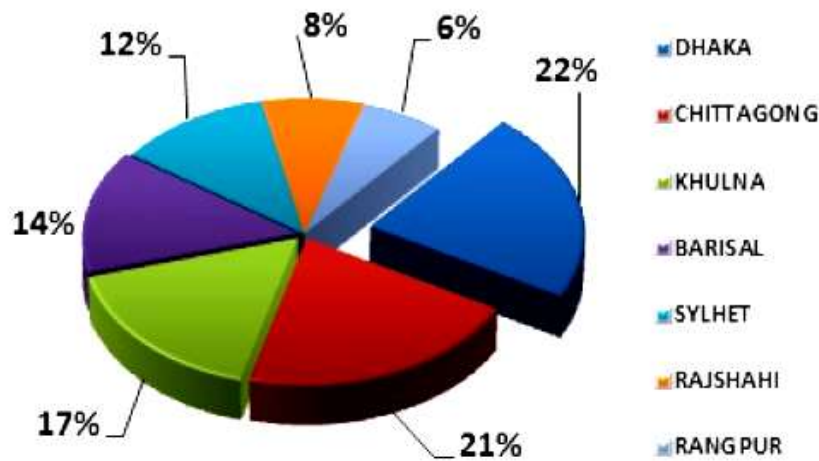

Fig. 1.2: Distribution of SHSs in seven divisions of Bangladesh<sup>[14]</sup>

### 1-5-2 Wind Energy

It has been studied that the average wind speed is maximum during the month of April which is approximately  $5.3 \text{ ms}^{-1}$  and minimum in the month of December which is around  $2.6 \text{ ms}^{-1}$  in Bangladesh.

Organization Name	Type of Application	Installed Capacity (Watt)	Location	Present Status
Grameen Shakti	3 Hybrid	4,500	Grameen Offices in Coastal Region	Functioning
	Hybrid	7,500	Cyclone Shelter in Coastal Region	Functioning
BRAC	Stand-alone	900	Coastal Region	Functioning
	Hybrid	4,320	Coastal Region	Functioning
Bangladesh Army	Stand-alone	400	Chittagong Hill Tracts	Functioning
IFDR	Stand-alone	1,100	Teknaf	Functioning
	Stand-alone	600	Meghnaghat	Functioning
LGED	Wind-PV	400	Kuakata	Functioning
	Hybrid			
	Total	19,720		

Table 1.1: Wind turbine installations in Bangladesh by different organizations<sup>[3]</sup>

There is a good in Island and coastal areas for the application of windmills for electricity generation. The Table 1.1 shows an overall project on the wind energy programs undertaken by different organizations of Bangladesh.

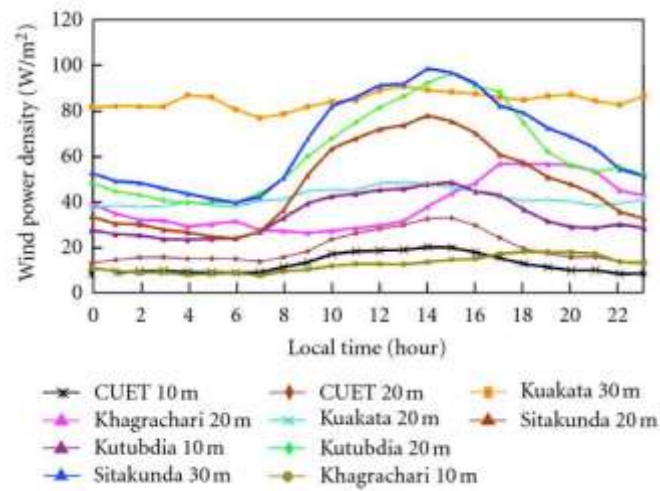

Fig. 1.3: Wind power density at different areas for different period<sup>[1]</sup>

In Fig. 1.3 wind power density for different areas in Bangladesh is shown based on the statistical reports. This shows the probability of power sectors for this renewable energy.

### 1-5-3 Biomass Energy

Since Bangladesh is an agricultural country so biomass is available in huge amount. Cattle dung, agricultural residue and waste, poultry dropping, water hyacinth, rice husk etc. used for biomass power generation are available in Bangladesh. <sup>[3]</sup>

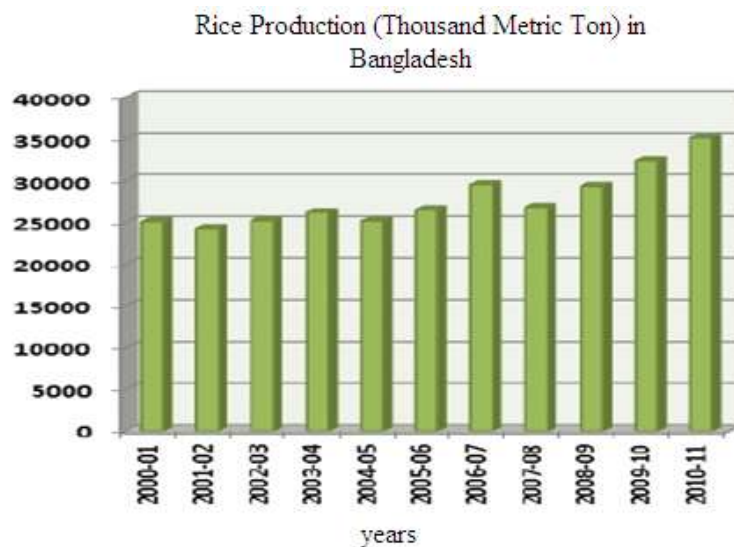

Fig. 1.4: Rice production (Thousand Metric Ton) in Bangladesh in past 11 years<sup>[14]</sup>

The Fig. 1.3 indicates that the amount of rice production in Bangladesh has been increased in recent years and this amount of production has made us more optimistic in using the rice husk as a biomass fuel which is a perfect source of renewable energy in the context of Bangladesh.

To tap the unharnessed potential of biomass energy resources, IDCOL financed the first and only biomass gasification based commercial power plant at Kapasia of Gazipur district. The project, which has an installed capacity of 250 KW, was initiated in 2005 by Dreams Power Private Limited (DPPL).<sup>[4]</sup> The project started its commercial operation in October, 2007.

#### **1-5-4 Hydropower**

---

A recent study on Sustainable Rural Energy shows that micro hydro power plants are able to provide necessary power supply for rural areas. The study was conducted on the micro hydro power plants of generation capacity starting from 3 KW up to 30 KW. These plants are in:

- Nunchari Tholipara, Khagrachari
- Chang-oo-Para, Bandarban
- Bangchari, Bandarban
- Liragaon, Bandarban
- Kamalchar, Rangamati
- Thang Khrue, Rangamati
- Monjaipara, Bandarban

Now, two fundamental conclusions may be drawn. First, we understand, to a certain extent, what will be needed to cope with large-scale renewable in the grid – but we do not yet have what we need. Very considerable efforts will be needed to obtain it, whether it is knowledge, practical experience, tools, guidance or investment. Secondly, neither theoretical knowledge nor practical experience is enough if it is applied by just those who know, or just those who have the experience, separately in their own domains. That is happening today, and it will obviously not be able to cope with the increase in renewable. Instead, it will be required to attack the problem together, across borders and areas of responsibility, basing the

solutions on common research, tools and infrastructure, and in particular on common rules and international standards. The problem is too complex for any other approach to work.

### 1-6 Block Diagram of Grid Integration of Renewable Energy

Interconnection of a photovoltaic (PV) power system in place of the wind turbine is considered in this example. Solar/DC source is converted into AC through the gate driver circuit by taking a reference sinusoidal signal from the grid. Then the inverted AC signal is filtered for getting a pure sinusoid. Finally the inverted AC signal is given to the synchronizer which synchronizes the signal with the grid. <sup>[5]</sup> This basic block is shown in Fig. 1.4.

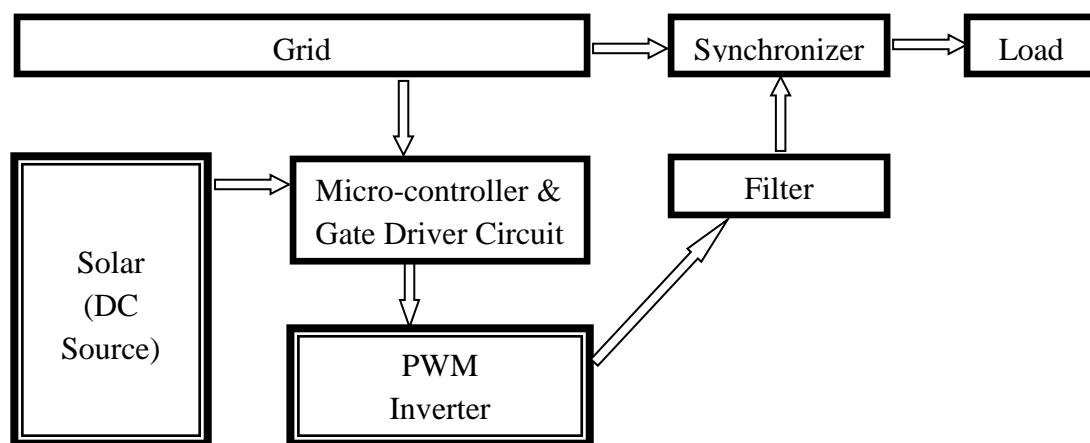

Fig. 1.5: Schematic arrangement of grid connected PV system

### 1.7 Terms of Synchronism

For synchronizing the renewable energy to the grid, three terms are there which should be performed to be synchronized. They are:

- I. The amplitude of the phase voltages of the grid and output phase voltages from the inverter should be matched.
- II. The phase angle of the phase voltages of the grid and output phase voltages from the inverter should be matched.
- III. The frequency of the phase voltages of the grid and output phase voltages from the inverter should be matched.

**LITERATURE REVIEW**

We will discuss in this chapter about:

- Operation of different types of Converters such as DC-DC, AC-DC & DC-AC.
- Switching technique of the Converters.
- Analyzing the outputs of the Converters with their performance.
- Finally simulation of the Converters in the MATLAB.

**2-1 DC-DC Converters**

It is one type of converter which converts one level of DC voltage to another level of DC voltage. As we can't use transformer in the DC power system, here we have to use these DC-DC converters. Like a transformer used in the AC system, the voltage can be also stepped down or stepped up by using the DC-DC converters used in DC system. <sup>[6]</sup>

They are useful in many electronic equipments as well as electrical systems. They do have smooth acceleration control, high efficiency and fast dynamic responses. That's why they are used in marine hoists, forklift trucks, mine haulers and auto mobiles. In electronic devices they are useful for cellular phones, laptop etc where they are used to store the power using battery. DC converters have a useful operation in the DC voltage regulators. For this switching mode operation of the DC-DC converters are used where the output can be controlled.

We will discuss here about:

- Buck Converter
- Boost Converter
- Buck-boost Converter
- Cúk Converter

**2-1-1 Principle of operation of Buck Converter**

The name "Buck Converter" presumably evolves from the fact that the input voltage is bucked/chopped or attenuated, in amplitude and a lower amplitude voltage appears at the output. <sup>[7]</sup> This converter is used as step down transformers. For any input DC voltage, it gives an output of DC lower from the input. In the Fig. 2.1 a simple step down converters circuit diagram is shown. Normally this converter is used for DC motor controlling purpose.

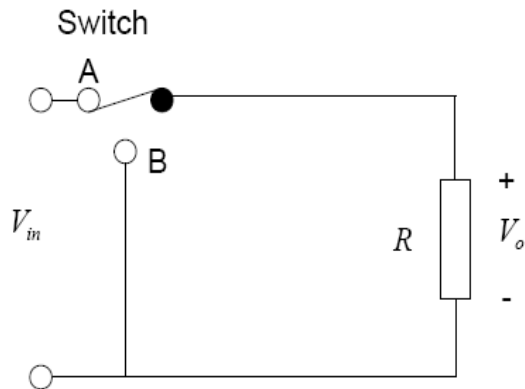

Figure 2.1: Buck Converter

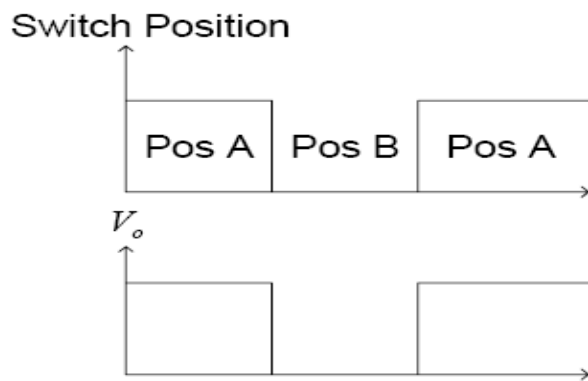

Figure2.2: Output Voltage of Buck Converter

In the Fig. 2.2 the respective output for the load voltage is shown. For the circuit in Fig. 2.1, the output voltage equals the input voltage when the switch is in position A and it is zero when the switch is in position B. By varying the duration for which the switch is in position A and B, it can be seen that the average output voltage can be varied. The avg. output voltage will be less than the input. The resulting will have a pulsed output. [8]

$$\text{Now, } V_o = \frac{1}{T} \int_0^{t_{on}} V_o(t) dt = V_s \frac{t_{on}}{T} = DV_s \dots \dots \dots (2.1)$$

$$\text{Where, D is the duty ratio. From (2.1): } V_{rms} = \sqrt{\int_0^{t_{on}} V_o(t)^2 dt} = \sqrt{DV_s} \dots \dots \dots (2.2)$$

Now, from (2.1) the output voltage varies with the duty ratio. The relation is linear. As the range of duty ratio is always less or equal to 1, so the output voltage will be less or equal to the input voltage.

### 2-1-1-1 ON State operation of Buck Converter

Refer to Fig. 2.3, when the converter is at ON State then the diode is reversed biased, so the inductor is connected in series with the capacitor and the load. The inductor does the smoothing process of the output voltage and it reduces the ripples in output. The inductor current increases, inducing a positive voltage drop across the inductor and a lower output supply voltage in reference to the input source voltage. The inductor serves as a current source to the output load impedance.

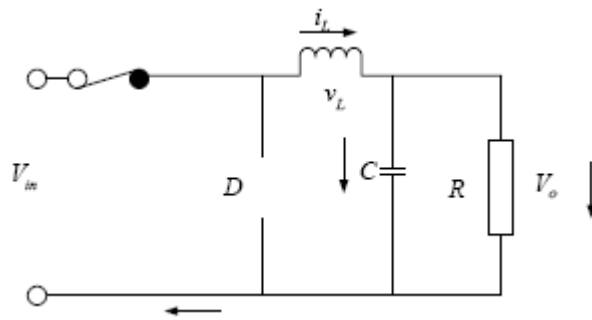
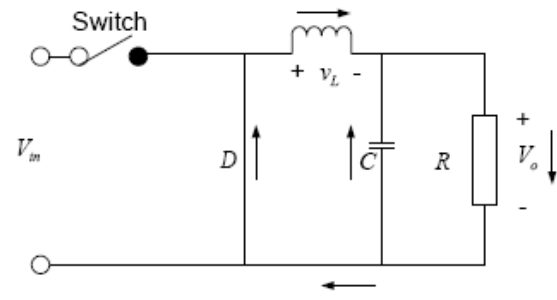
Figure 2.3: ON State operation of Buck Converter<sup>[15]</sup>Figure 2.4: OFF State operation of Buck Converter<sup>[15]</sup>

### 2-1-1-2 OFF State operation of Buck Converter

In the OFF state <sup>[8]</sup> (Fig. 2.4) the switch is open, diode D conducts and energy is supplied from the magnetic field of L and electric field of C. The current through the inductor falls linearly. When the switch is off, the inductor current discharges, inducing a negative voltage drop across the inductor. Because one port of the inductor is tied to ground, the other port will have a higher voltage level, which is the target output supply voltage. The output capacitance acts as a low-pass filter, reducing output voltage ripple as a result of the fluctuating current through the inductor. The diode prevents the current flowing from the inductor when the switch is off.

### 2-1-1-3 MATLAB Simulation for Buck converter

Now an example of designing a buck converter with using MOSFET switch is given here. Values of the parameters taken for the converter are given below in Table 2.1:

Name	Value
DC Voltage source	100Volt DC
Inductor	1e-3H
Capacitor	1e-9F
Load	1ohm
Duty Ratio	50%
Pulse width	2000Hz

Table 2.1: Circuit Parameters Data of Buck Converter for MATLAB Simulation

The simulation arrangement is shown in below:

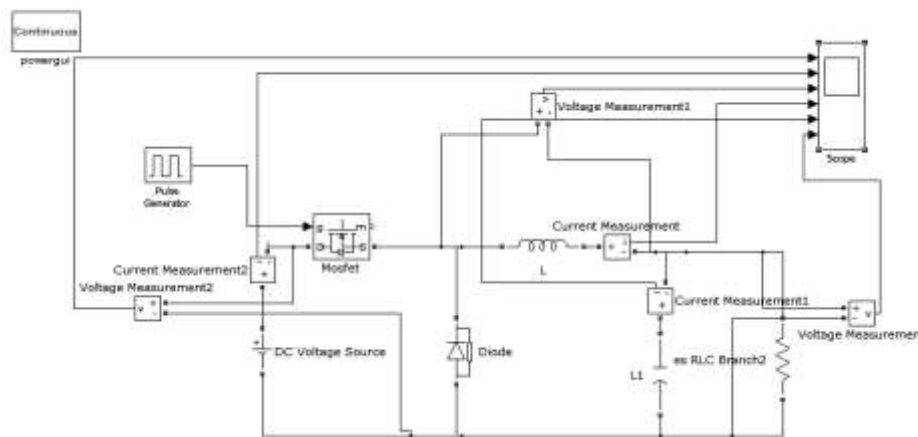

Fig. 2.5: MATLAB Simulation for Buck Converter

The output waveforms for the buck converter designed with the above data by simulating at MATLAB is given below:

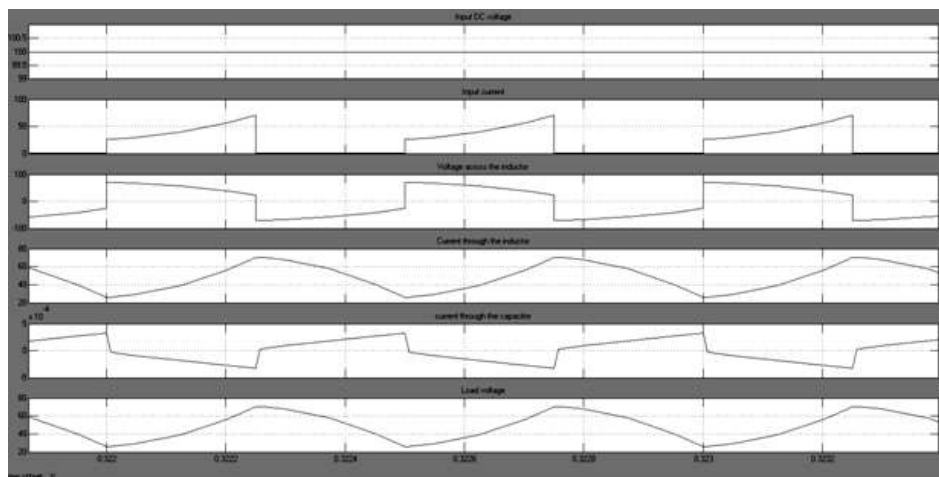

Fig. 2.6: Output wave shapes for the simulation of buck converter in MATLAB

### 2-1-2 Principle of operation of Boost Converters

In this converter the converted output voltage is always greater than the input voltage. Normally they are used in regulated DC power supply, the regenerative braking of the DC motor. The basic boost converter circuit consists of only a switch (typically a transistor), a diode, an inductor, and a capacitor. [7] The specific connections are shown in Fig.2.7.

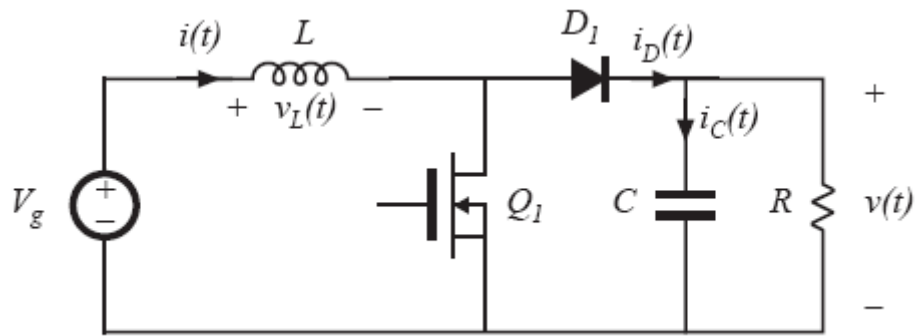

Fig. 2.7: Configuration of a Boost converter

### 2-1-2-1 ON State operation of Boost Converters

When the MOSFET switch  $Q_1$  is on then the diode is reversed biased and it isolates the output voltage from the input. <sup>[8]</sup> Then the voltage across the inductor is same as the input voltage. This configuration is shown in Fig.2.8.

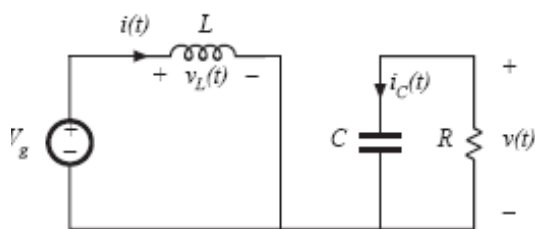

Figure 2.8: ON State operation of Boost Converter

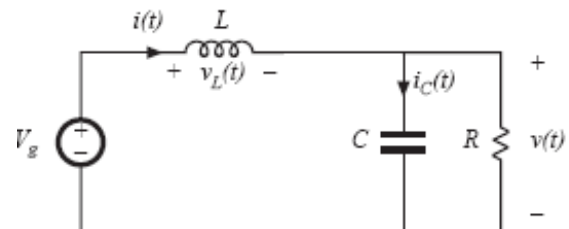

Figure 2.9: OFF State operation of Boost Converter

### 2-1-2-2 OFF State operation of Boost Converters

When the switch is at off state then the diode is forward biased and connects the inductor to the capacitor and load. <sup>[8]</sup> The inductor voltage is the difference between the source voltage and the capacitor voltage. It is shown in Fig.2.9.

The output inductor voltage for both of this configuration is shown in Fig.2.10:

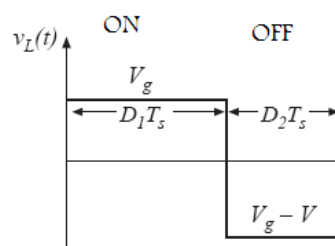

Fig.2.10: Inductor Voltage for Boost converter

As the time integral of inductor voltage over one period is equal to zero, we can write:

$$\int_0^{T_s} V_L d(t) = 0$$

$$\text{Or, } \int_0^{t_{on}} V_L d(t) + \int_{t_{on}}^{T_s} V_L d(t) = 0$$

$$\text{Or, } V_d D T_s + (V_d - V_o)(T_s - T_s D) = 0 \text{ [As } D = \frac{t_{on}}{T_s}]$$

$$\text{Or, } \frac{V_o}{V_d} = \frac{1}{1-D} \dots \dots \dots (2.3)$$

This is the characteristics equation for boost converters.

### 2-1-2-3 MATLAB Simulation for Boost converter

Now an example of designing a boost converter with using MOSFET switch is given here. Values of the parameters taken for the converter are given below in Table2.2:

Name	Value
DC Voltage source	100Volt DC
Inductor	1e-4H
Capacitor	1e-2F
Load	10ohm
Duty Ratio	50%
Pulse width	2000Hz

Table 2.2: Circuit Parameters Data of Boost Converter for MATLAB Simulation

The simulation arrangement is shown in below:

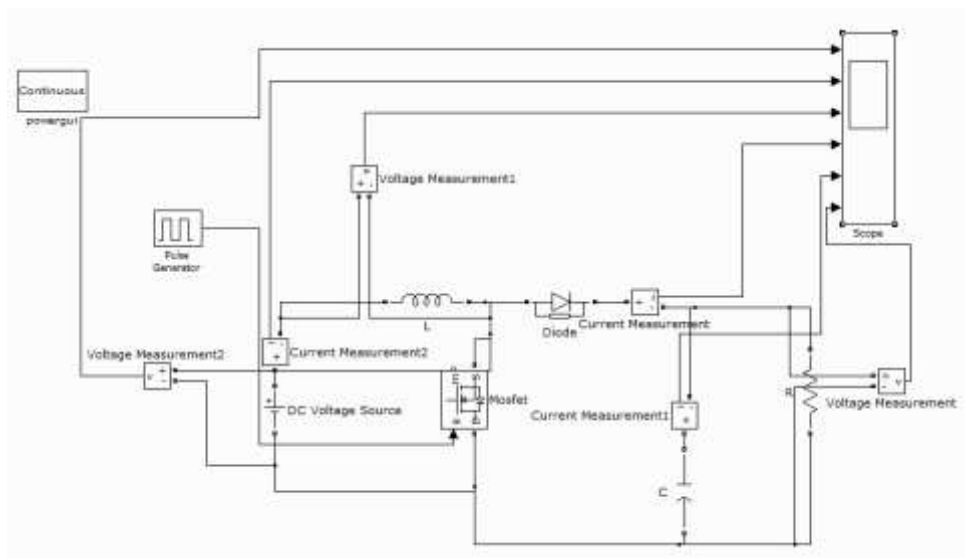

Fig. 2.11: MATLAB simulation for the Boost Converter

The output waveforms for the boost converter designed with the above data by simulating at MATLAB is given below:

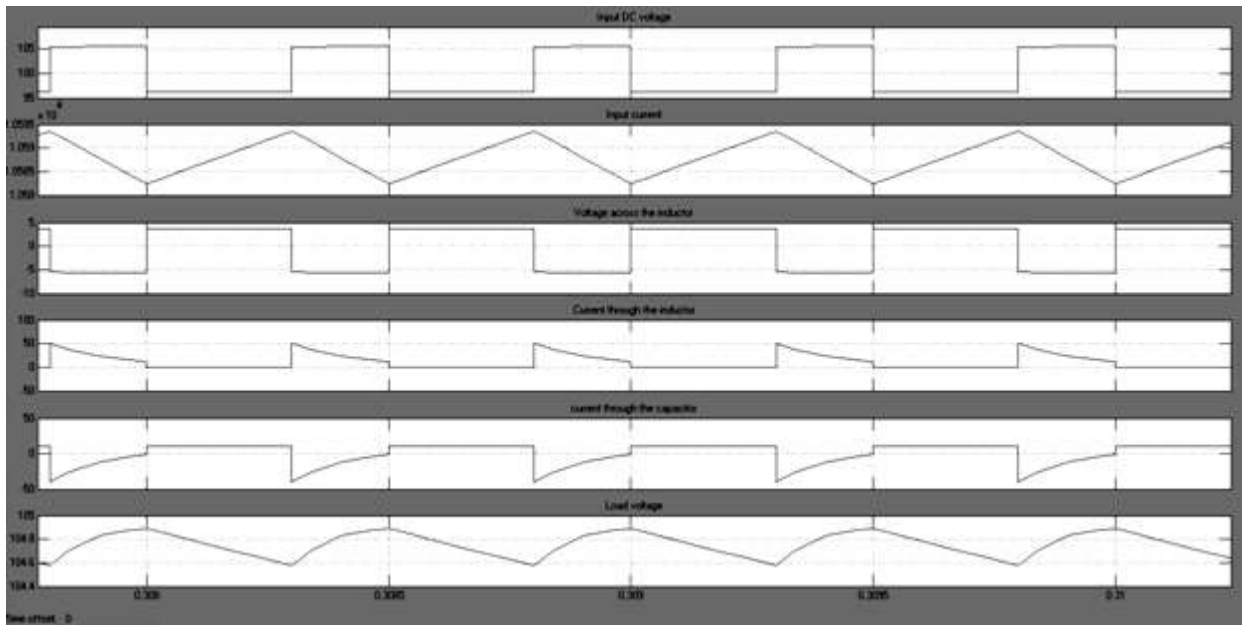

Fig. 2.12: Simulated out of the Boost Converter

### 2-1-3 Operating Principle of Buck-Boost Converters

The output of the buck boost regulators (Fig. 2.13) can be less than or greater than the input DC voltage. Here one most important thing is that, the output is opposite to the given input voltage. For this it is also known as an inverting regulator. [8]

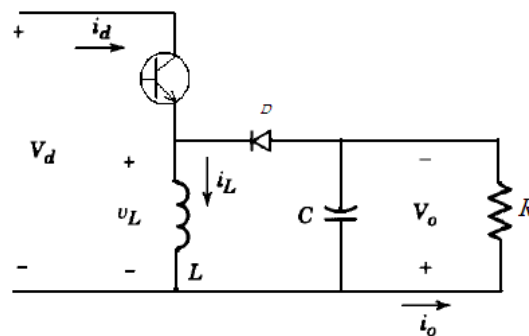

Fig. 2.13: Schematic of a buck-boost converter[8]

#### 2-1-3-1 ON State Operation of Buck-Boost Converters

When the transistor switch is on then the diode is reversed biased and it isolates the output voltage from the input. [8] Then the voltage across the inductor is same as the input voltage. This configuration is shown in Fig.2.14.

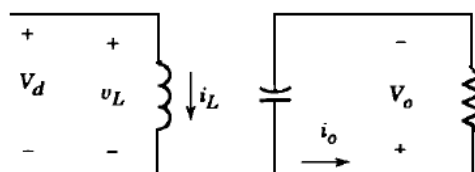

Fig. 2.14: On state of Buck-Boost converter[8]

### 2-1-3-2 OFF State Operation of Buck-Boost Converters

In this time the MOSFET switch is turned off and the whole circuit is isolated from the input voltage. As the diode is in forward biased now, the inductor will be discharged through the capacitor and the resistor. The configuration is shown in Fig. 2.15:

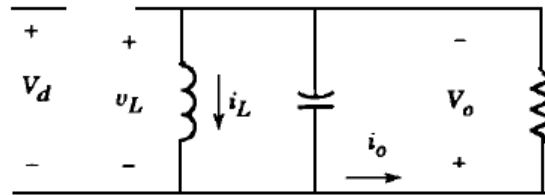

Fig. 2.15: Off state of Buck-Boost converter<sup>[8]</sup>

The output inductor voltage for both of this configuration is shown in Fig.2.16:

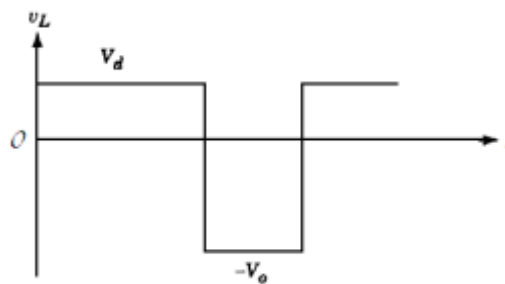

Fig. 2.16: Inductor voltage for buck-boost converter

Now, equating the integral of the inductor voltage over one time period, we get:

$$V_d D T_s - V_o T_s (1 - D) = 0$$

$$\text{So, } \frac{V_o}{V_d} = \frac{-D}{1-D} \dots \dots \dots (2.4)$$

Here, it is seen that the output is inverted and the output equation is the combined equation of buck and boost converter. Hence it is called buck-boost converter.

### 2-1-3-3 MATLAB Simulation for Buck-Boost converter

Now an example of designing a buck-boost converter with using MOSFET switch is given here. Values of the parameters taken for the converter are given below in Table 2.3:

Name	Value
DC Voltage source	100Volt DC
Inductor	1e-4H
Capacitor	1e-2F
Load	10ohm
Duty Ratio	60%
Pulse width	2000Hz

Table 2.3: Circuit Parameters Data of Buck-Boost Converter for MATLAB Simulation

The simulation arrangement is shown below:

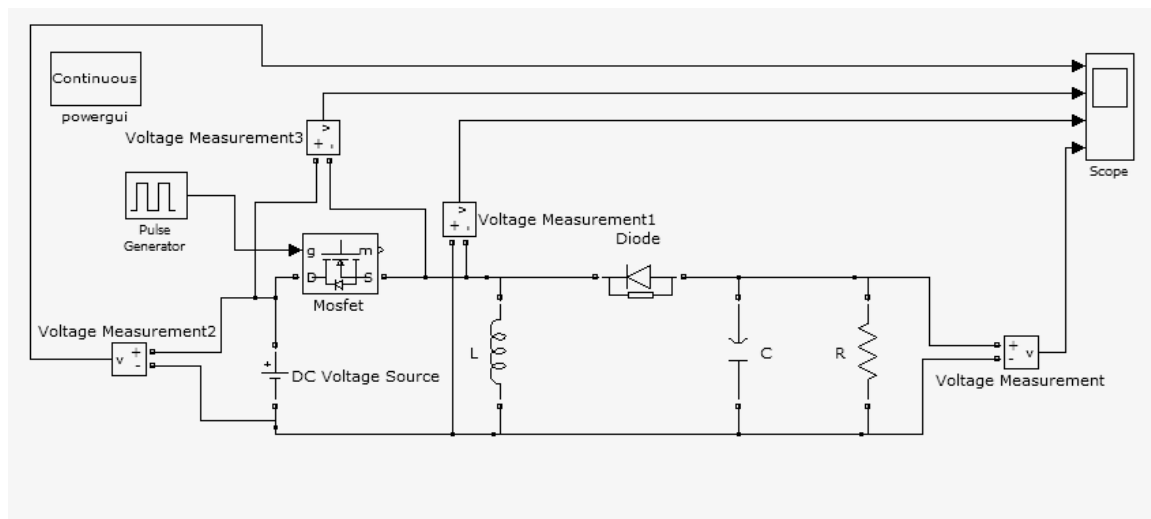

Fig. 2.17: MATLAB Simulation for buck-boost converter

The simulated outputs are given at Fig. 2.18.

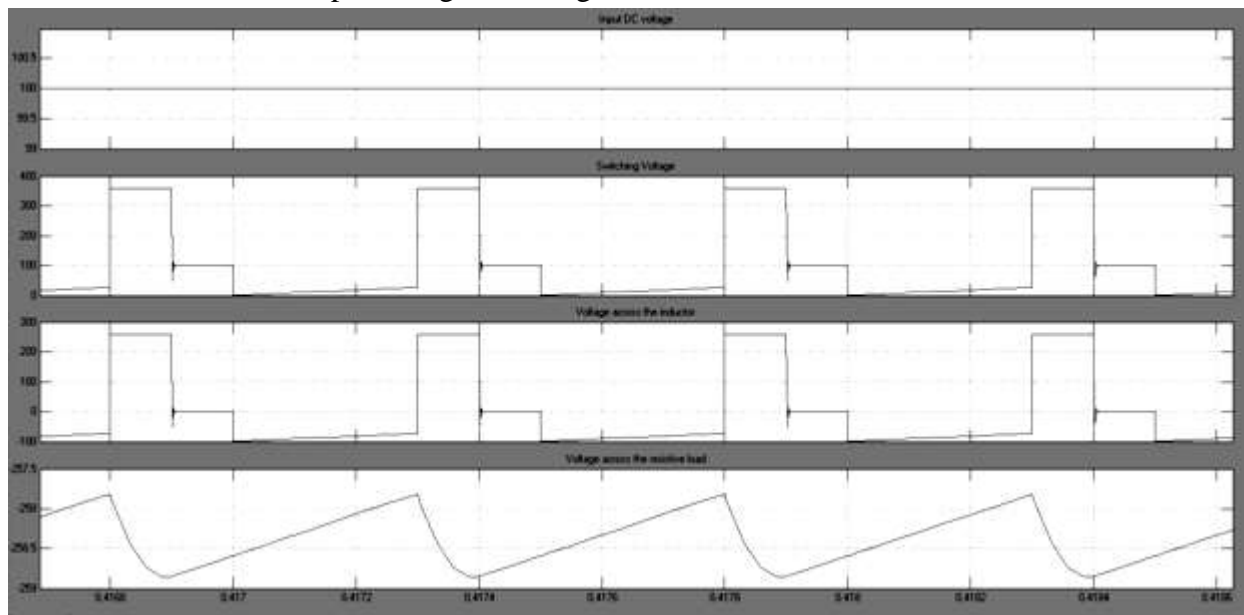

Fig. 2.18: Output for buck-boost converter

### 2-1-4 Cúk Converter

It is named after its inventor. It provides an output voltage that is less than or greater to the input voltage similar to the buck-boost regulator and the output voltage is opposite to the input voltage. [8] Mainly, the Cúk regulator uses capacitive energy transfer based on the current balance of the capacitor. The circuitry arrangement for the Cúk converter is shown in Fig. 2.19:

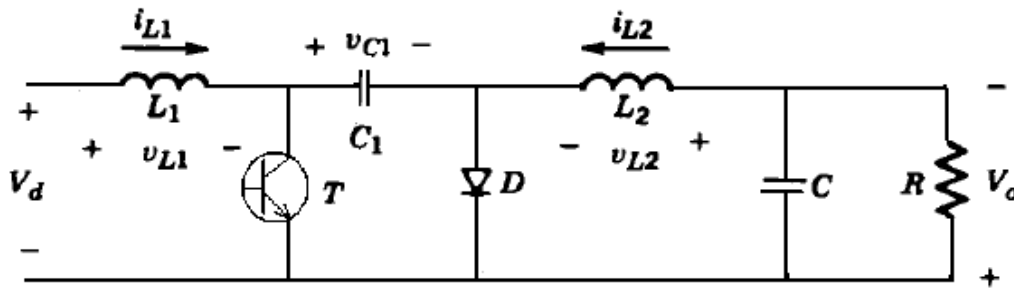

Fig. 2.19: Schematic of Cúk converter<sup>[8]</sup>

It generally consists of two inductors, two capacitors, switch and a diode. As being an inverting converter the output voltage is negative with respect to the input voltage. The capacitors are used to store energy and inductors are to convert the voltage sources to current source.

### 2-1-4-1 On State Operation of Cúk Converter

During On state, the transistor switch is turned off and the diode  $D$  conducts. For the on state operation of the Cúk Converter, the circuit is shown in the Fig. 2.20.

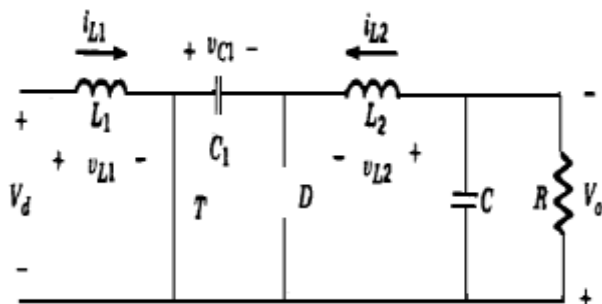

Fig. 2.20: On state of Cúk Converter<sup>[8]</sup>

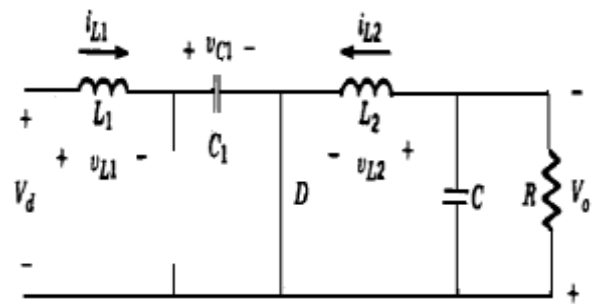

Fig. 2.21: Off state of Cúk Converter<sup>[8]</sup>

### 2-1-4-2 Off State Operation of Cúk Converter

In the Off state, the transistor switch is turned on and the diode becomes reversed biased. For this, the diode does not conduct. The circuit is shown in Fig. 2.21.

The output voltages across the inductors are shown in Fig. 2.22:

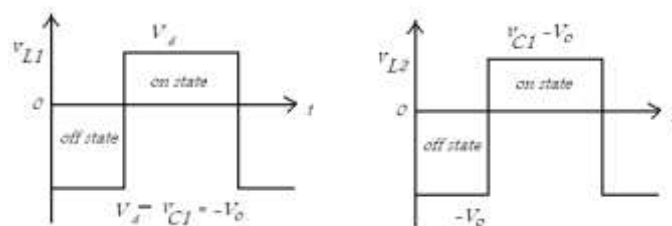

Figure 2.22: Output Inductor voltages for the Cúk Converter

The output characteristics equation is given by: 
$$\frac{V_o}{V_d} = \frac{-D}{1-D} \dots \dots \dots (2.5)$$

### 2-1-4-3 MATLAB Simulation for Cúk Converter

Now an example of designing a Cúk Converter with using MOSFET switch is given here. Values of the parameters taken for the converter are given below in Table 2.4:

Name	Value
DC Voltage source	100Volt DC
Inductor	L1=6mH, L2=3mH
Capacitor	C1=4.4 $\mu$ F, C2=6.7 $\mu$ F
Load	5ohm
Duty Ratio	60%
Pulse width	2000Hz

Table 2.4: Circuit Parameters Data of Cúk Converter for MATLAB Simulation

The simulation arrangement is shown in Fig. 2.23:

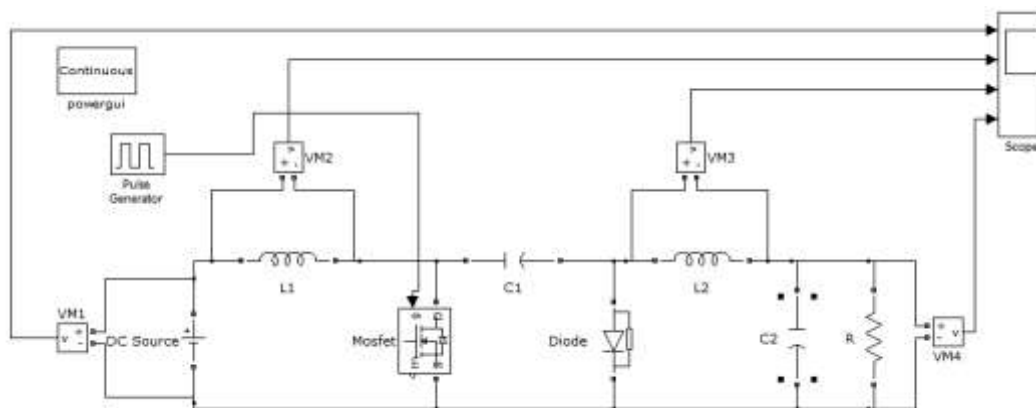

Fig. 2.23: MATLAB Simulation for Cúk Converter

The simulation output wave shapes are given below:

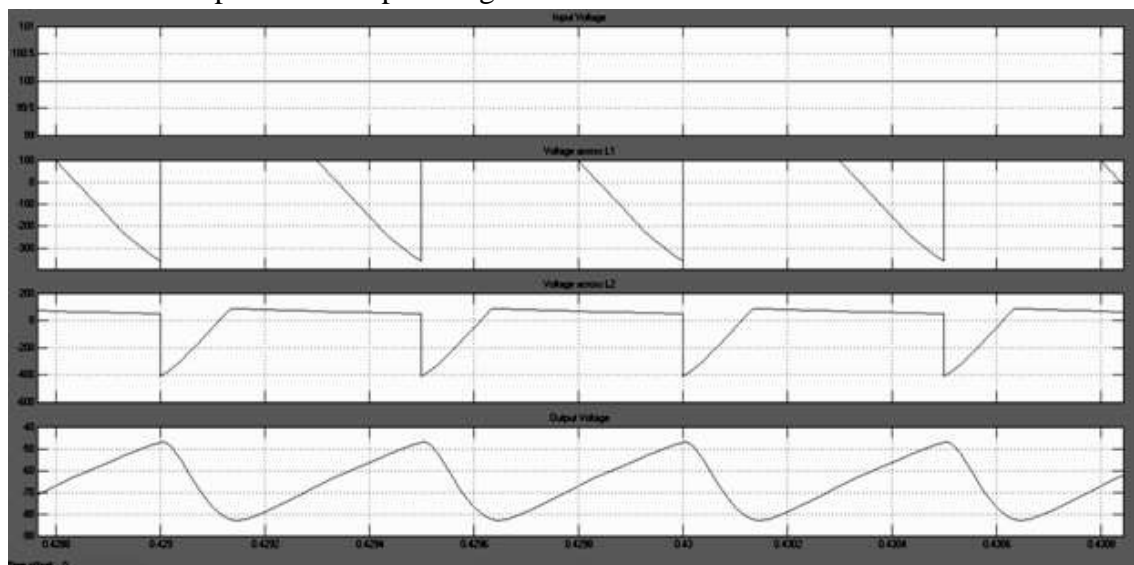

Fig. 2.24: Simulated waveforms for the Cúk Converter

## 2-2 Rectifiers

Here we will discuss about controlled and uncontrolled rectifiers. The rectifiers are used to convert an AC signal to the DC signal. They can be single phase or three phase. Here the power flow is done from the AC side to the DC. In many electronics components usually power electronics components DC supply is needed. For this rectification is done while they are fed from the AC supply<sup>[7]</sup>. The output of the rectifiers should be ripple free as possible. They are usually applicable for the charger, battery, DC motor driver, DC servo motor driver etc. Also, for the uninterruptable power supply where low power is consumed rectifiers are used. In the uncontrolled rectifiers diode are used and in the controlled rectifiers thyristors are used normally. In our report, we will discuss about one example of each uncontrolled and controlled rectifiers.

### 2-2-1 Three-phase Uncontrolled Rectifiers

Here the output can't be controlled. This rectifier (Fig. 2.25) consists of three legs having two diodes at each leg. It acts as a bridge which converts the AC input to the DC output on the basis of the conduction of the diodes. The conduction sequences of diodes are D1-D2; D3-D2; D3-D4; D5-D4; D5-D6 and D1-D6. Every pair diodes are connected to the pair of supply lines. The output can be made pure DC without ripples using filters.

MATLAB simulation for the three-phase bridge rectifier with 220volt at each phase is given here with a resistive load:

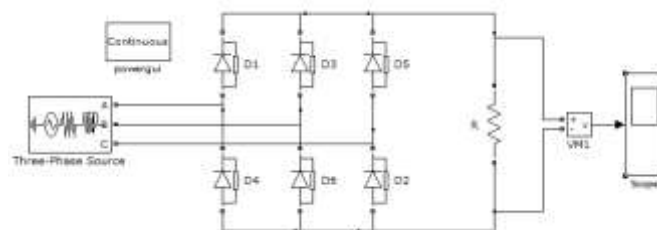

Fig. 2.25: MATLAB Simulation for three phase controlled bridge rectifier

The simulated output voltage wave shape is given below:

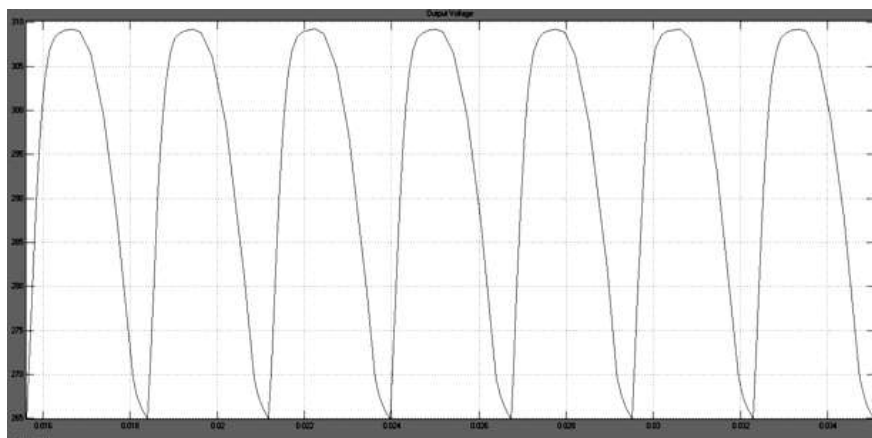

Fig. 2.26: Output voltage for diode bridge rectifier

## 2-2-2 Three-phase Controlled Rectifiers

The configuration is same as the uncontrolled one with one difference is that; here thyristors are used instead of the diodes. For this, the output can be controlled by changing the firing angle of thyristors. [7]

For the same configuration as the uncontrolled bridge rectifier, the MATLAB simulation of the controlled rectifier is shown below in Fig. 2.27 with the output with 45° firing angle:

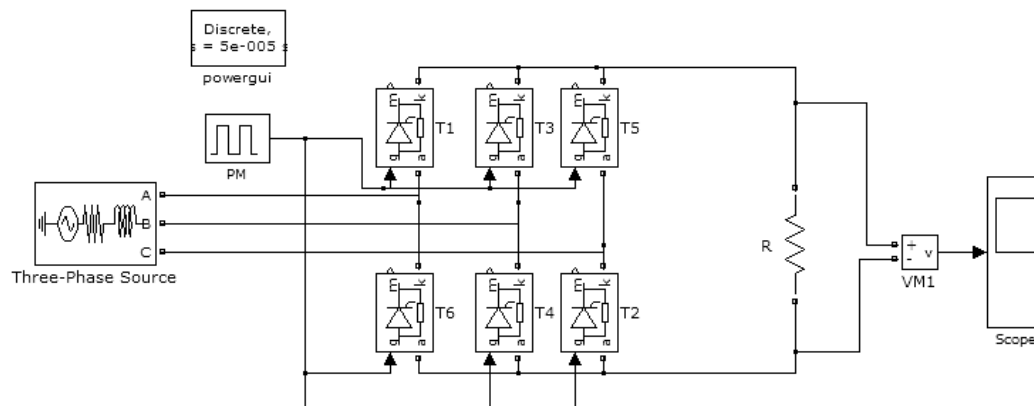

Fig. 2.27: Controlled Bridge Rectifier Simulation

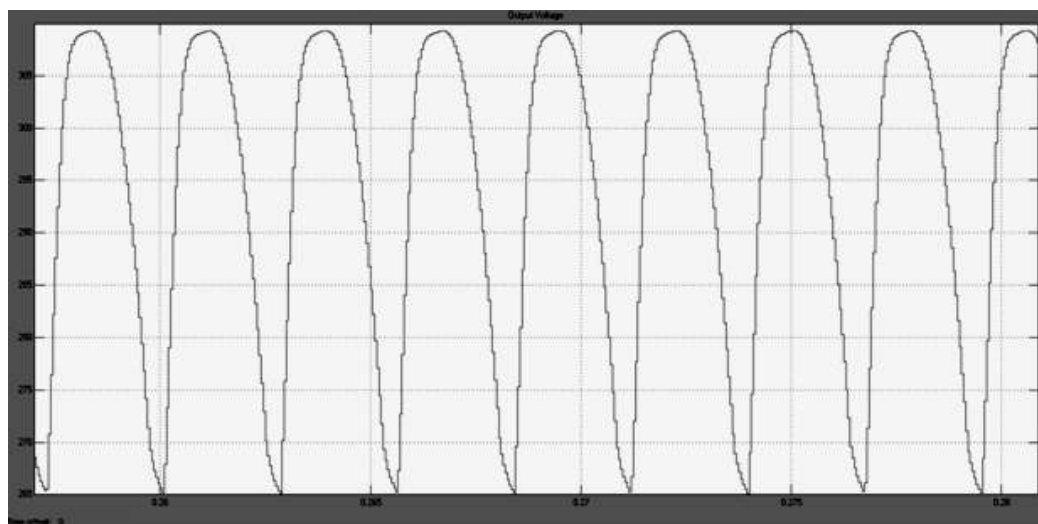

Fig. 2.28: Simulated output for controlled bridge rectifier with 45° firing angle

## 2-3 Voltage Source Inverters

The main objective of static power converters is to produce an AC output waveform from a DC power supply. [9] These are the types of waveforms required in adjustable speed drives (ASDs), uninterruptible power supplies (UPS), static var compensators, active filters, flexible AC transmission systems (FACTS), and voltage compensators, which are only a few

applications. For sinusoidal AC outputs, the magnitude, frequency, and phase should be controllable.

According to the type of AC output waveform, these topologies can be considered as voltage source inverters (VSIs), where the independently controlled AC output is a voltage waveform. These structures are the most widely used because they naturally behave as voltage sources as required by many industrial applications, such as adjustable speed drives (ASDs), which are the most popular application of inverters. Similarly, these topologies can be found as current source inverters (CSIs), where the independently controlled AC output is a current waveform. These structures are still widely used in medium-voltage industrial applications, where high-quality voltage waveforms are required. Static power converters, specifically inverters, are constructed from power switches and the AC output waveforms are therefore made up of discrete values. This leads to the generation of waveforms that feature fast transitions rather than smooth ones.

For instance, the AC output voltage produced by the VSI of a standard ASD is a three-level waveform (Fig. 2.29c). Although this waveform is not sinusoidal as expected (Fig. 2.29b), its fundamental component behaves as such.

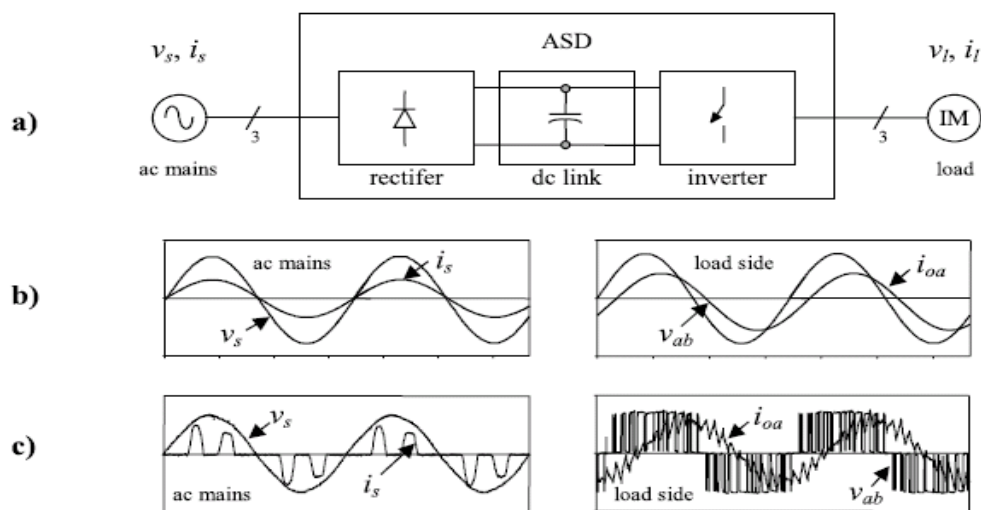

Fig. 2.29: The AC output voltage produced by the VSI of a standard ASD

- a) The electrical power conversion topology;
- b) The ideal input (ac mains) and output (load) waveforms; and
- c) The actual input (ac mains) and output (load) waveforms<sup>[9]</sup>

### 2-3-1 Full-Bridge VSI

Fig. 2.30 shows the power topology of a full-bridge VSI. This inverter is similar to the half-bridge inverter; however, a second leg provides the neutral point to the load. As expected, both switches  $S_{1+}$  and  $S_{1-}$  (or  $S_{2+}$  and  $S_{2-}$ ) cannot be on simultaneously because a short circuit across the DC link voltage source  $V_i$  would be produced [7]. There are four defined (states 1, 2, 3, and 4) and one undefined (state 5) switch states as shown in Table 2.5. The undefined condition should be avoided so as to be always capable of defining the AC output voltage. It can be observed that the AC output voltage can take values up to the DC link value  $V_i$ , which is twice that obtained with half-bridge VSI topologies. Several modulating techniques have been developed that are applicable to full-bridge VSIs. Among them are the PWM (bipolar and unipolar) techniques.

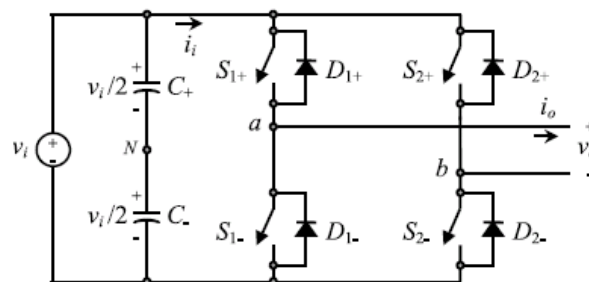

Fig. 2.30: Single-phase full-bridge VSI<sup>[7]</sup>.

State	State	$v_a$	$v_b$	$v$	Components Conducting
<b>1+, 2- are on and 1-, 2+ are off</b>	1	$v/2$	$-v/2$	$v$	1+ & 2-; if $> 0$ 1+ & 2-; if $< 0$
<b>1-, 2+ are on and 1+, 2- are off</b>	2	$-v/2$	$v/2$	$-v$	1- & 2+; if $> 0$ 1- & 2+; if $< 0$
<b>1+, 2+ are on and 1-, 2- are off</b>	3	$v/2$	$v/2$	0	1+ & 2+; if $> 0$ 1+ & 2+; if $< 0$
<b>1-, 2- are on and 1+, 2+ are off</b>	4	$-v/2$	$-v/2$	0	1- & 2-; if $> 0$ 1- & 2-; if $< 0$
<b>1-, 2-, 1+ and 2+ are all off</b>	5	$-v/2$ $v/2$	$v/2$ $-v/2$	$-v$ $v$	1- & 2+; if $> 0$ 1+ & 2-; if $< 0$

Table 2.5: Switch states for a full-bridge single-phase VSI

#### 2-3-1-1 MATLAB Simulation for Full Bridge VSI

Now an example of designing a Full Bridge VSI with using IGBT switch is given here. Values of the parameters taken for the converter are given below in Fig. 2.31:

Name	Value
DC Voltage source	100Volt DC
Capacitor	2e-6F
Load	10ohm
Duty Ratio	50%
Pulse width	50Hz
Pulse delay for IGBT 1 & 2	100Hz

Table 2.6: Circuit Parameters Data of full bridge VSI for MATLAB Simulation

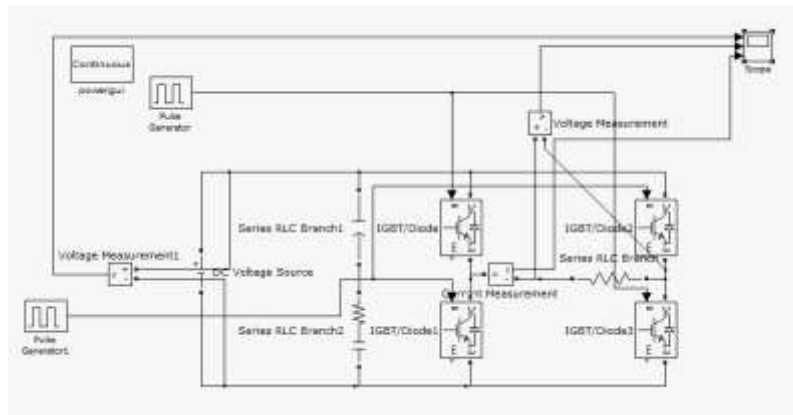

Fig. 2.31: MATLAB Simulation for single phase full bridge VSI

The output waveforms for the Full Bridge VSI designed with the above data by simulating at MATLAB is given below (Fig. 2.32):

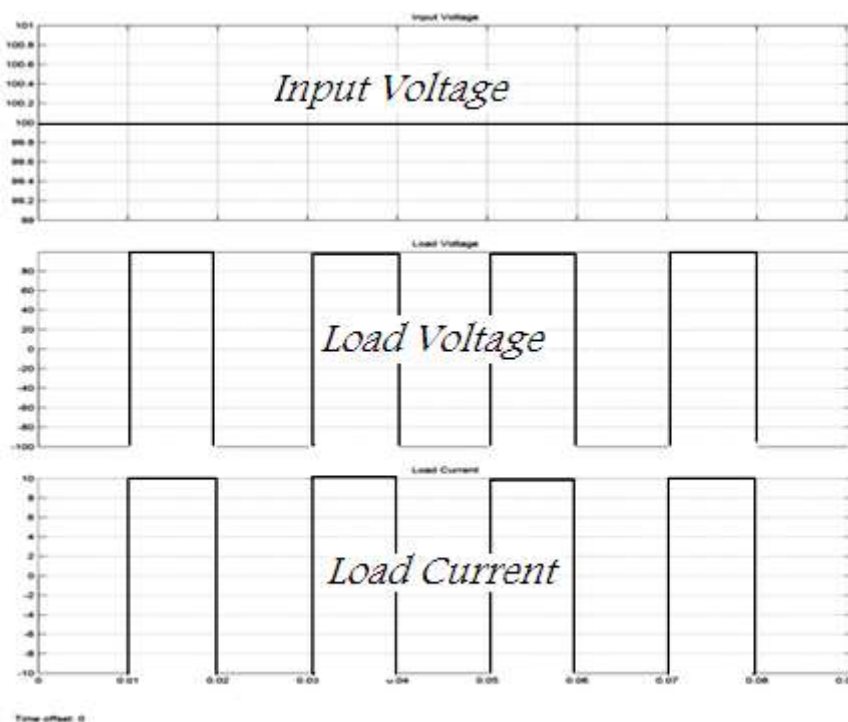

Fig. 2.32: Simulated output of the single phase full bridge VSI

**SINUSOIDAL PULSE WIDTH MODULATED INVERTER**

This chapter will contain about:

- Modeling of a PWM (Pulse Width Modulated) Inverter with mathematical illustration and output wave shapes.
- Also there will be a described topology for integrating renewable source to the grid through PWM Inverter.

**3.1 Introduction**

The DC-ac converter which is also known as the inverter converts DC power to the AC power at a desired output voltage and frequency. <sup>[8]</sup> The DC power input to the inverter is obtained from an existing power supply network or from a rotating alternator through a rectifier or a battery, fuel cell, photovoltaic array or magneto hydrodynamic generator also said to be from renewable energy sources. Filter capacitor across the input terminals of the inverter provides a constant DC link voltage. The configuration of AC to DC converter and DC to AC inverter is called a DC link converter.

Inverters can be broadly classified into two types, voltage source and current source inverters. The voltage at the input terminals is constant. A voltage source inverter employing thyristors as switches, some type of forced commutation is required, while the VSIs made up of using GTOs, power transistors, power MOSFETs or IGBTs, self commutation with base or gate drive signals for their controlled turn-on and turn-off.

A standard single-phase voltage or current source inverter can be in the half bridge or full-bridge configuration. Some industrial applications of inverters are for adjustable-speed AC drives, induction heating, standby aircraft power supplies, UPS (uninterruptible power supplies) for computers, HVDC transmission lines, etc.

**3.2 PWM & SPWM**

In PWM the amplitude of each sample of the original signal is encoded into the duration of corresponding pulse. <sup>[10]</sup> The main signal is encoded according to the reference signal. The basic block diagram of PWM is shown in Fig. 3.1.

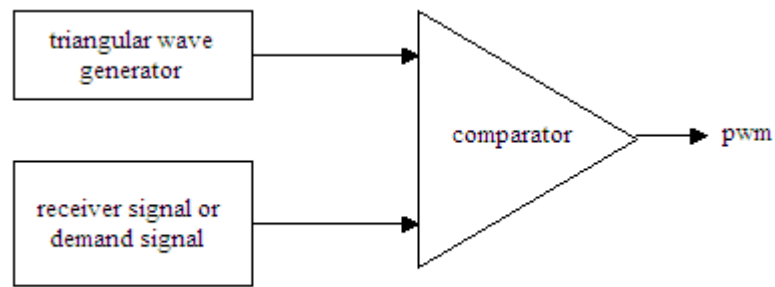

Fig. 3.1: Basic block diagram of PWM

With a triangular reference signal which is shown in the diagram below (Fig. 3.2) shows how comparing a ramping waveform with a DC level produces the PWM waveform that we require. For the higher the DC level is, the wider the PWM pulses are. The DC level is the 'demand signal'. The DC signal can range between the minimum and maximum voltages of the triangle wave. When the triangle waveform voltage is greater than the DC level, the output of the comparator swings high, and when it is lower, the output swings low.

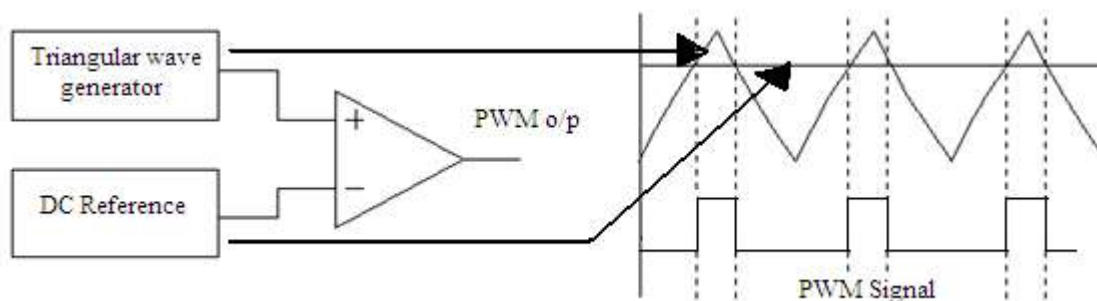

Fig. 3.2: Generation of PWM using comparator

An application of PWM is given here: PWM is a method of controlling the amount of power to a load without having to dissipate any power in the load driver. Imagine a 10W light bulb load supplied from a battery. In this case the battery supplies 10W of power, and the light bulb converts this 10W into light and heat. No power is lost anywhere else in the circuit. If we wanted to dim the light bulb, so it only absorbed 5W of power, we could place a resistor in series which absorbed 5W and then the light bulb could absorb the other 5W. This would work, but the power dissipated in the resistor not only makes it get very hot, but is wasted. The battery is still supplying 10W. <sup>[12]</sup>

An alternative way is to switch the light bulb on and off very quickly so that it is only on for half of the time. Then the average power taken by the light bulb is still only 5W, and the average power supplied by the battery is only supplying 5W also. If we wanted the bulb to take 6W, we could leave the switch on for a little longer than the time it was off, then a

little more average power will be delivered to the bulb. This on-off switching is called PWM. The amount of power delivered to the load is proportional to the percentage of time that the load is switched on.

Now, the basic does not have any difference between the PWM and SPWM (Sinusoidal Pulse Width Modulation) instead that in the SPWM the reference signal is sinusoidal and triangular signal is the carrier. <sup>[8]</sup> In this type of modulation the width of the pulses vary with the amplitude of the sine wave evaluated at the center of the same pulse. It is commonly used in industrial applications. One type of SPWM signal is shown in Fig. 3.3. <sup>[13]</sup>

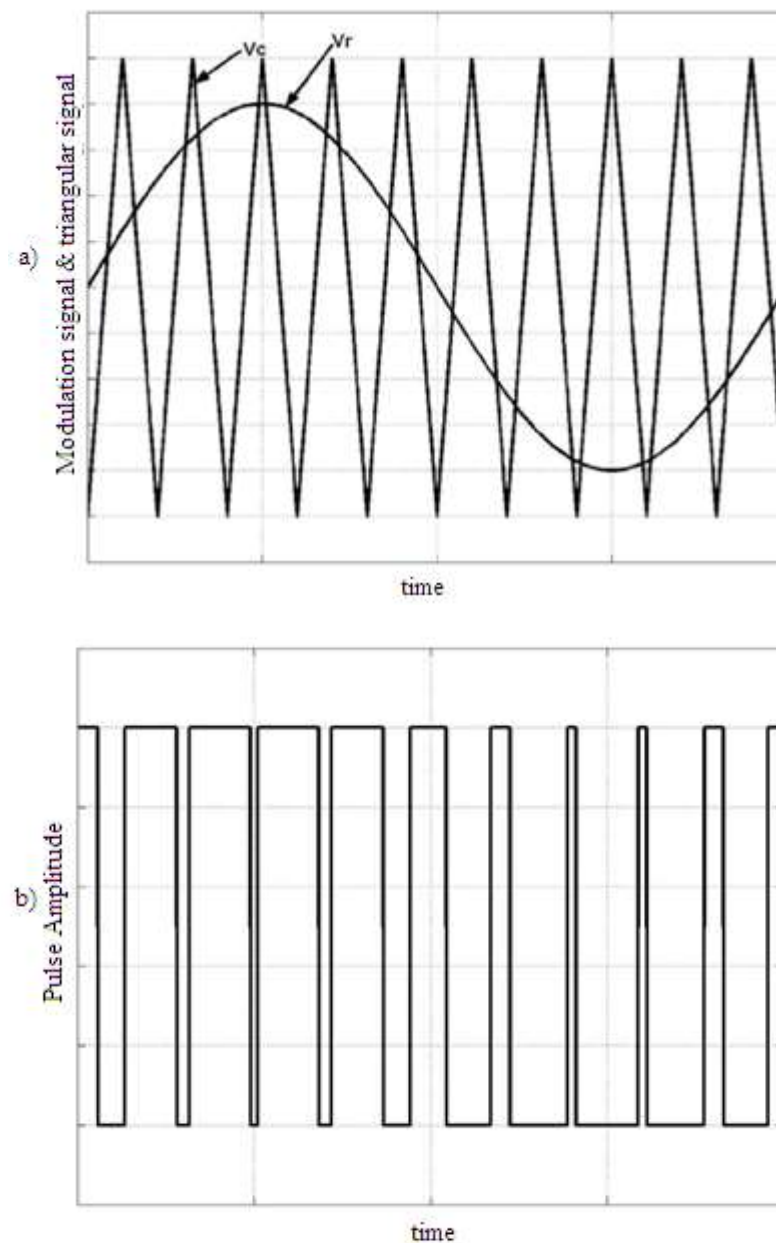

Fig. 3.3: SPWM Topology a) Sine-triangular comparison, b) Switching pulses or modulated signal Here,  $V_c$  is the carrier signal i.e. triangular signal and  $V_r$  is the reference signal.

### 3.3 Mathematical Modeling of SPWM Switching Scheme:

The sinusoidal PWM (SPWM) method also known as the triangulation, sub harmonic, or sub oscillation method, is very popular in industrial applications and is extensively reviewed in the literature. In order to produce Pulse Width Modulated Signal, the reference sinusoidal signal is compared with a triangular signal which is shown in Fig.. This is done at a desired frequency. The frequency of the carrier wave or the triangular signal is kept constant along its amplitude  $V_C$ .<sup>[8]</sup> The carrier frequency  $f_c$  which is also the frequency of the carrier signal is the cause of the switching of the IGBTs in the inverter.

The reference signal or the sinusoidal signal is  $V_s$  cause of the change of the duty ratio which has a frequency called modulated frequency  $f_s$ . This is the fundamental frequency of the inverter. The inverter output will contain the harmonics of this frequency.

Now, the amplitude modulation ratio  $m_a = \frac{V_s}{V_C} \dots \dots \dots (3.1)$

Here the amplitude of  $V_C$  is always kept constant.

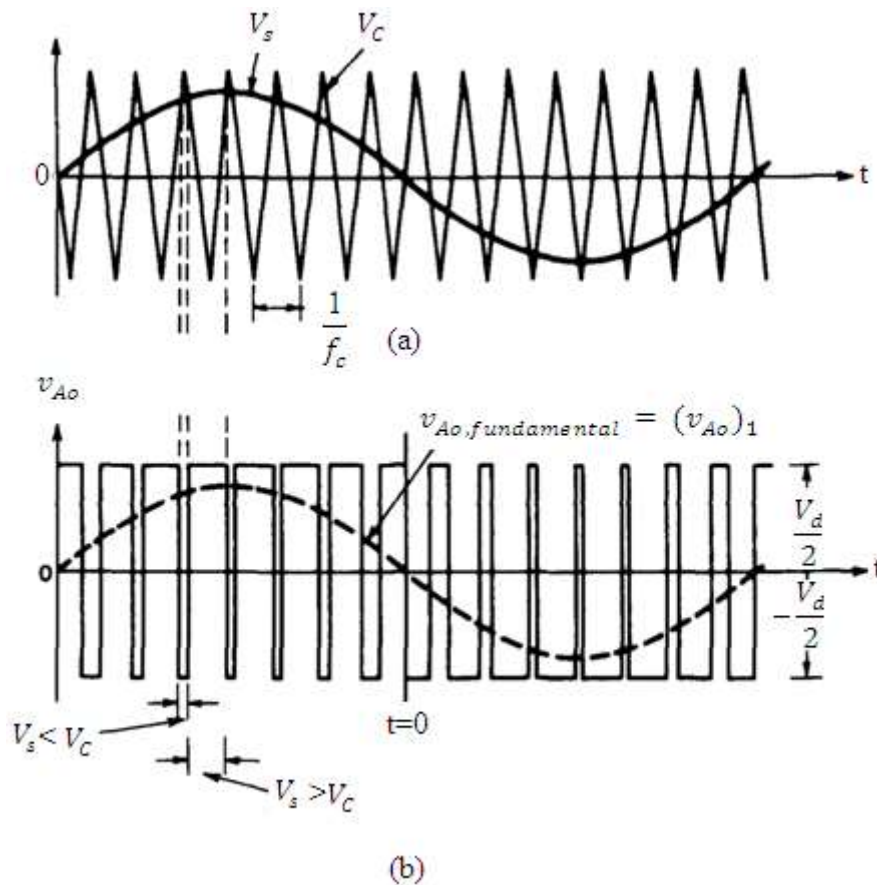

Fig. 3.4: Sinusoidal Pulse Width Modulation Technique<sup>[8]</sup>

Again, the frequency modulation ratio  $m_f = \frac{f_c}{f_s} \dots \dots \dots (3.2)$

Now, let us consider the single phase inverter circuit which has only a single leg shown in Fig. 3.5.

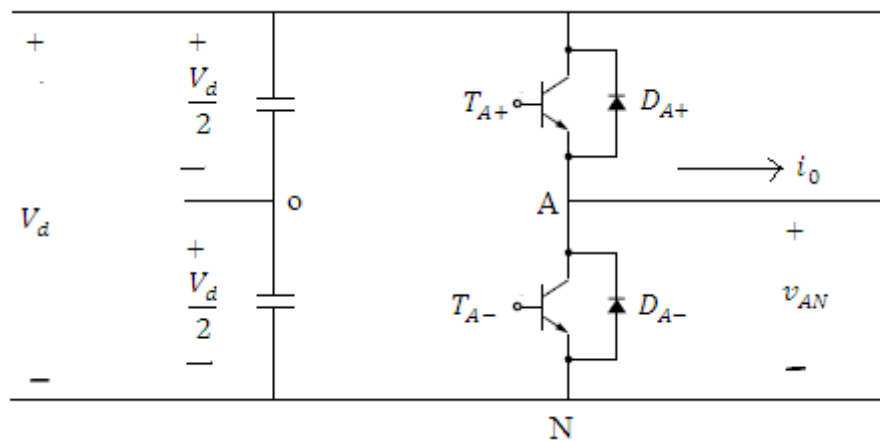

Fig. 3.5: Single phase, single legged PWM Inverter

The switches  $T_{A+}$  &  $T_{A-}$  are controlled by the output from the comparator which compares the voltages  $V_C$  &  $V_S$ . Now, depending on direction of the load current  $i_o$ , the following output voltages results:

When,  $V_S > V_C$ ; then  $T_{A+}$  is on and  $v_{Ao} = \frac{V_d}{2}$

Or,  $V_S < V_C$ ; then  $T_{A-}$  is on and  $v_{Ao} = -\frac{V_d}{2}$  ..... (3.3)

As the two switches do not turned off at the same time, so the output voltage fluctuates between  $\frac{V_d}{2}$  &  $-\frac{V_d}{2}$  which is an AC signal.

### 3.4 Amplitude Modulation for SPWM ( $m_a < 1$ ) and over modulation:

In the amplitude modulation for the SPWM, the amplitude modulation constant  $m_a$  must be less or equal to 1. Otherwise, there will be harmonics in the output when it is over modulated i.e. the amplitude modulation constant has a value greater than 1. When  $m_a < 1$ , PWM pushes the harmonics around the switching frequencies of the IGBTs or MOSFETs to its multiples. But, it is not always wishes that the maximum frequency will be allowable.

Now, when  $m_a > 1$ ; this is called over modulation. <sup>[7]</sup> During over modulation, the amplitude modulation index is increased beyond 1. Over modulation always causes an increased harmonics than under modulation. It has more disadvantages. In the over

modulation, the amplitude of the fundamental frequency does not vary linearly with the amplitude modulation index  $m_a$ . Fig. 3.6 shows the result of over modulation where  $m_a=1.2$

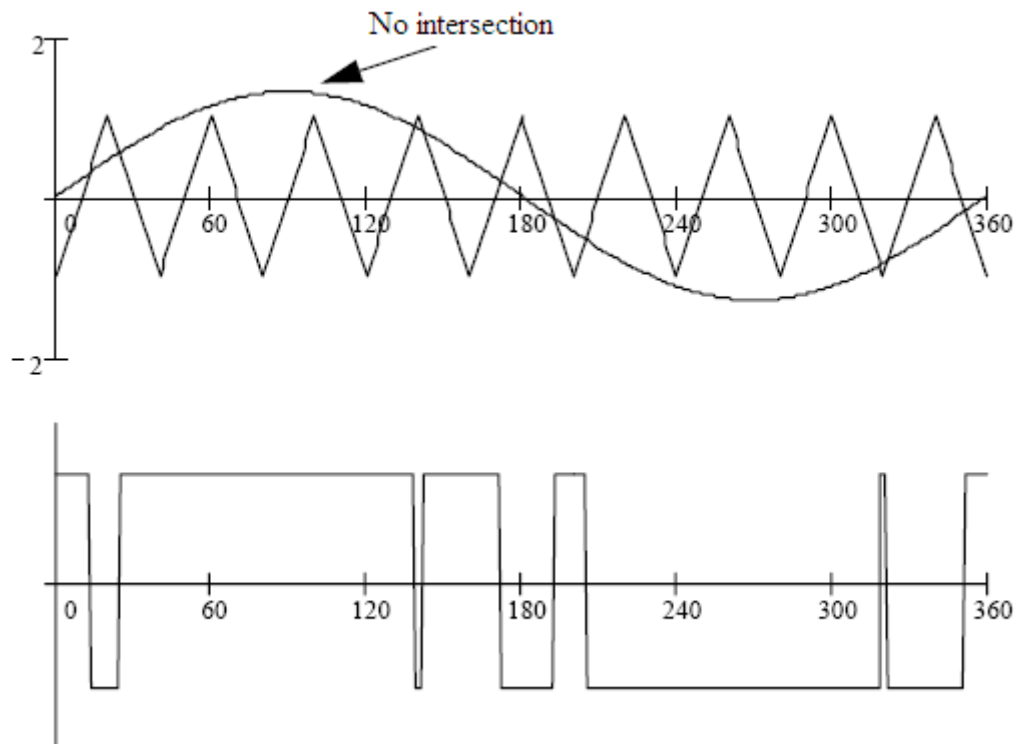

Fig. 3.6: Result of over modulation

If we see the harmonics spectrum of SPWM during over modulation and under modulation as shown in Fig. 3.6 & Fig. 3.7 respectively, it is shown that harmonics are increased during over modulation.

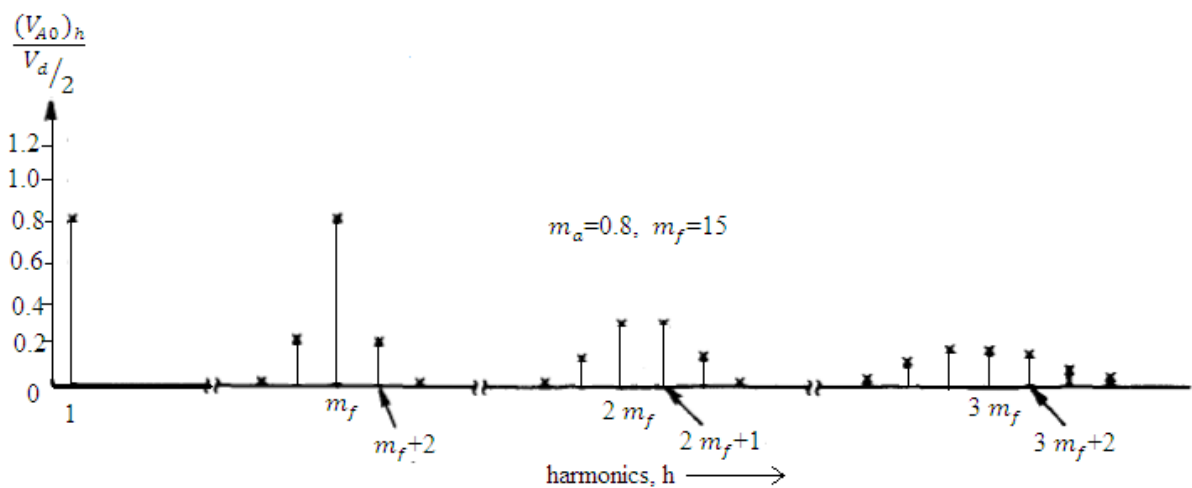

Fig. 3.7: Harmonics spectrum of PWM when  $m_a = 0.8$  <sup>[8]</sup>

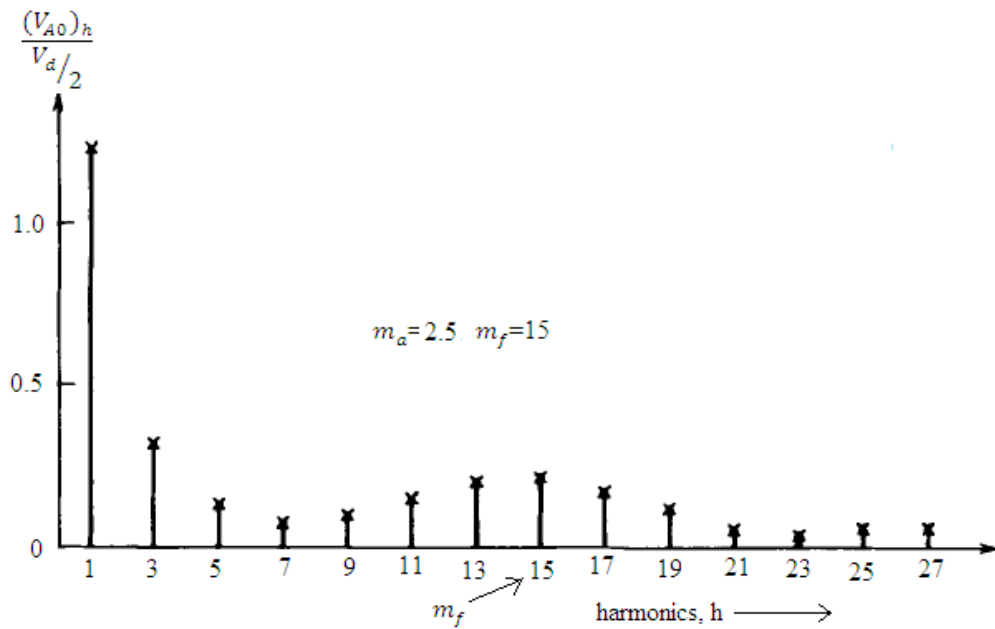

Fig. 3.8: Harmonics spectrum of PWM when  $m_a = 2.5$  [8]

In the Fig.,  $(V_{A0})_h$  is the voltage magnitude of the harmonic component and  $\frac{(V_{A0})_h}{V_d/2}$  is amplitude modulation ratio of the signal for that harmonic.

Now, if normalized peak amplitude of the fundamental frequency component  $\frac{(V_{A0})_1}{V_d/2}$  is plotted as a function of  $m_a$ , the relationship between them can be described as it is given in Fig. 3.8. [8]

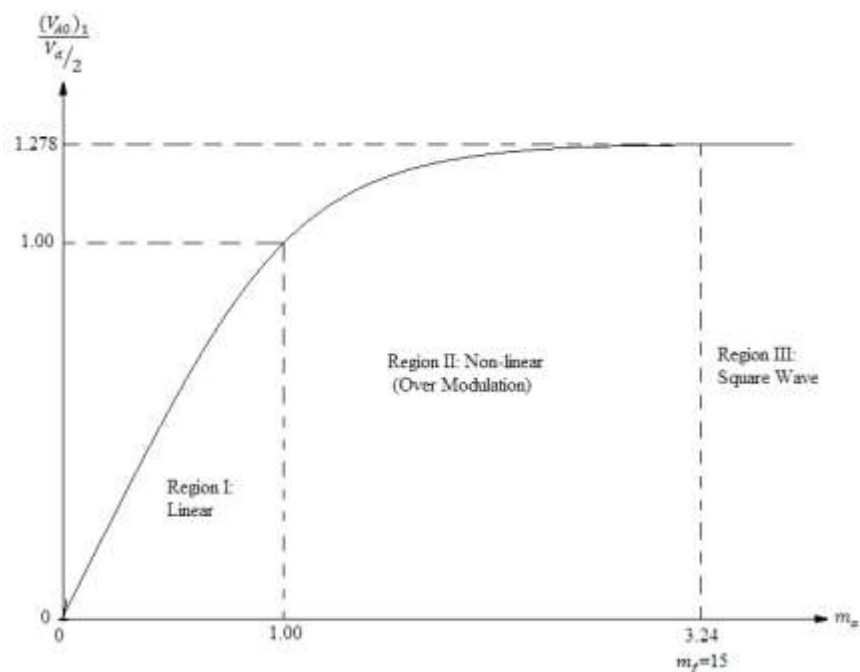

Fig. 3.9: Control of Voltage by varying  $m_a$  [8]

In region I, when  $m_a < 1$ ; then the relationship is linear and also dependent on  $m_f$ . This region is perfect for SPWM. In region II, the relationship is non-linear for  $m_a > 1$  and does exist up to a certain value of  $m_f$ . Here the signal is over modulated. In this region  $m_a$  also depends on  $m_f$ . But, in region III  $m_a$  is fully independent of  $m_f$ . This region is affordable for Square wave generation.

### 3.4 Bipolar Switching in SPWM:

Now, let us consider the circuit shown in Fig. 3.9. Here the switches  $S_{11}, S_{12}, S_{21}, S_{22}$  are connected in two legs of the inverter. In the bipolar switching of SPWM, the output voltage is fluctuated between two levels; hence it is called bipolar switching. [8]

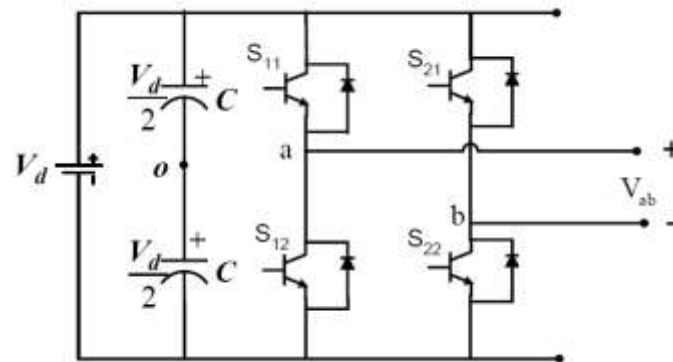

Fig. 3.10: SPWM Inverter (Full Bridge)

Now, for the bipolar switching, the switching pattern is shown below:

$$\text{When, } V_s > V_c; \text{ for } S_{11} \text{ is on } V_{a0} = \frac{V_d}{2} \text{ and } S_{22} \text{ is on } V_{b0} = -\frac{V_d}{2} \dots \dots \dots (3.4)$$

$$\text{When, } V_s < V_c; \text{ for } S_{12} \text{ is on } V_{a0} = -\frac{V_d}{2} \text{ and } S_{21} \text{ is on } V_{b0} = \frac{V_d}{2} \dots \dots \dots (3.4)$$

$$\text{Hence, } V_{a0}(t) = -V_{b0}(t) \dots \dots \dots (3.5)$$

So, the line to line voltage is given by:

$$V_{ab}(t) = V_{a0}(t) - V_{b0}(t) = 2V_{a0}(t) \dots \dots \dots (3.6)$$

The peak fundamental frequency component is given by:

$$V_{ab} = m_a V_d; \text{ for } m_a \leq 1 \dots \dots \dots (3.7)$$

$$V_d < V_{ab} < \frac{4}{\pi} V_d; \text{ for } m_a > 1 \dots \dots \dots (3.8)$$

Since the voltage fluctuates between  $V_d$  &  $-V_d$ , the scheme is called bipolar switching. In Fig. 3.11 (a) & (b), bipolar switching wave shapes are shown.

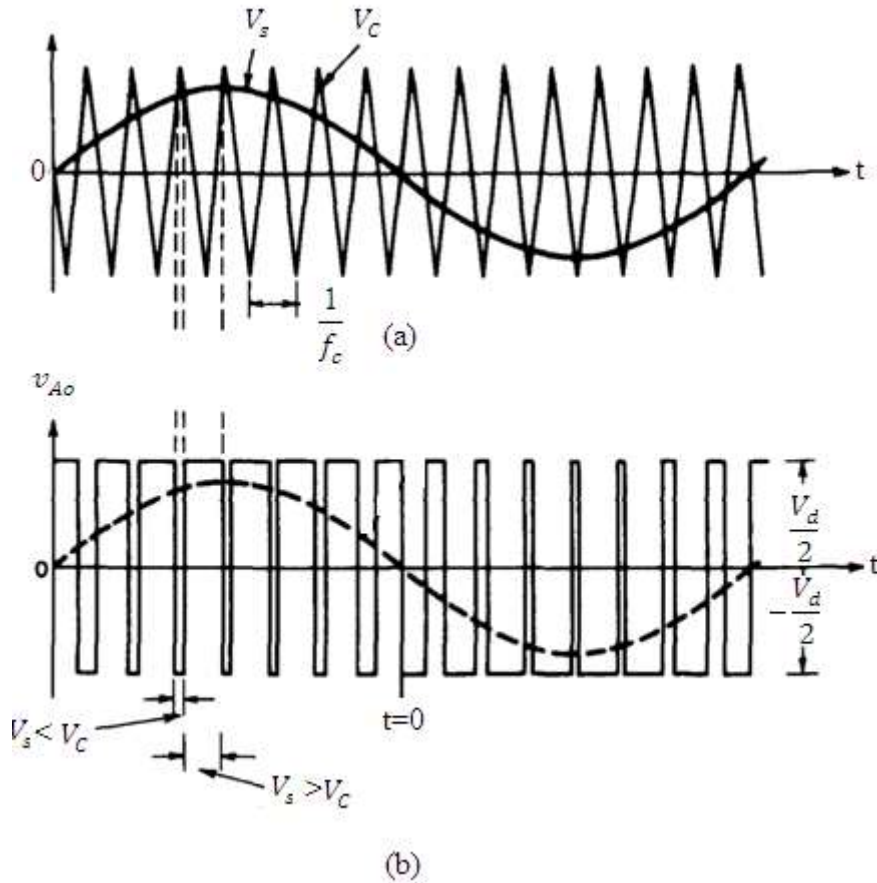

Fig. 3.11: SPWM with bipolar switching [8]

### 3.5 Unipolar Switching in SPWM:

In this scheme, the devices in one leg are turned on or off based on the comparison of the modulation signal  $V_s$  with a high frequency triangular wave. The devices in the other leg are turned on or off by the comparison of the modulation signal  $V_s$  with the same high frequency triangular wave.

Now, the logic behind the switching of the devices in the leg connected to ‘a’ is given as:

$$V_s > V_c: S_{11} \text{ is on } V_{an} = \frac{V_d}{2} \dots \dots \dots (3.9)$$

$$V_s < V_c: S_{11} \text{ is on } V_{an} = -\frac{V_d}{2} \dots \dots \dots (3.10)$$

Also for the leg connected to ‘b’ is given as:

$$-V_s > V_c: S_{11} \text{ is on } V_{bn} = \frac{V_d}{2} \dots \dots \dots (3.11)$$

$$-V_s < V_c: S_{11} \text{ is on } V_{bn} = -\frac{V_d}{2} \dots \dots \dots (3.12)$$

The line voltages and the output voltage are shown in Fig. 3.11 for the SPWM with unipolar switching.

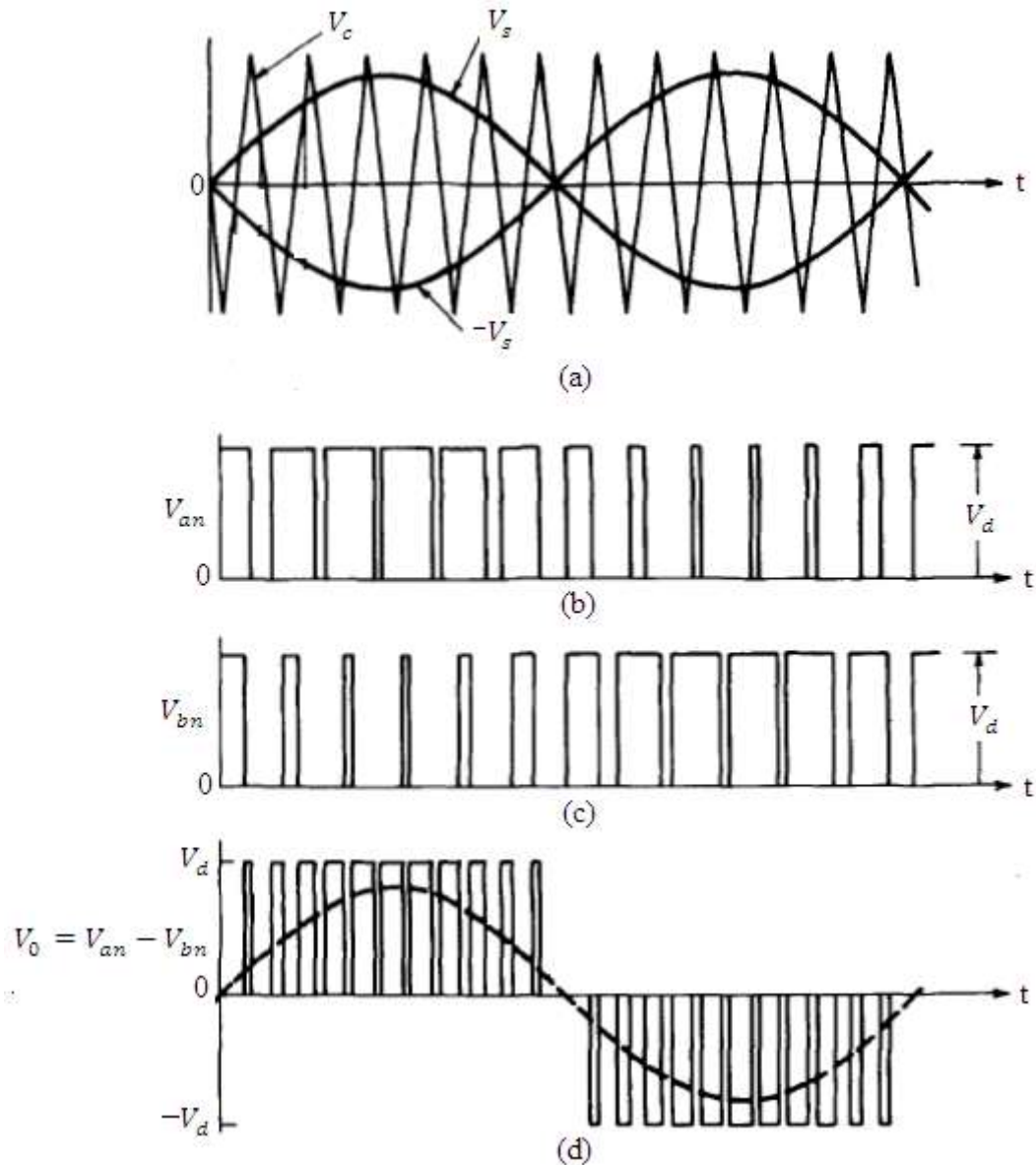

Fig. 3.12: SPWM with unipolar switching [8]

From the table 3.1, it is shown that, the switching states of the unipolar SPWM and the corresponding voltage levels. It can be observed from the table that when the two top or the two bottom devices are turned on the output voltage is zero. In Unipolar switching scheme the output voltage level changes between either 0 to  $V_d$  or from 0 to  $+V_d$ . This scheme

effectively has the effect of doubling the switching frequency as far as the output harmonics are concerned, compared to the bipolar- switching scheme.

$S_{11}$	$S_{12}$	$S_{21}$	$S_{22}$	$V_{an}$	$V_{bn}$	$V_0 = V_{an} - V_{bn}$
on	off	Off	On	$V_d$	0	$V_d$
off	on	On	Off	0	$V_d$	$-V_d$
on	off	On	Off	$V_d$	$V_d$	0
off	on	Off	On	0	0	0

Table 3.1: Switching states of the unipolar PWM and the corresponding voltage levels.

The fundamental component of the output voltage is given as:

$$V_0 = m_a V_d; \text{ for } m_a \leq 1 \dots \dots \dots (3.13)$$

$$V_d < V_0 < \frac{4}{\pi} V_d; \text{ for } m_a > 1 \dots \dots \dots (3.14)$$

### 3.6 SPWM in Three Phase Voltage Source Inverter

The process is same of SPWM in three phases as for the single phase is to control the output voltage with magnitude and frequency for a fixed DC input  $V_d$  in three phase SPWM inverter (Fig. 3.12). For this, we do need three triangular waves as for the carrier wave for every sinusoidal signal in each phase. The reference or control sinusoidal waves should be placed apart in  $120^\circ$  phase shift as shown in Fig. 3.13.

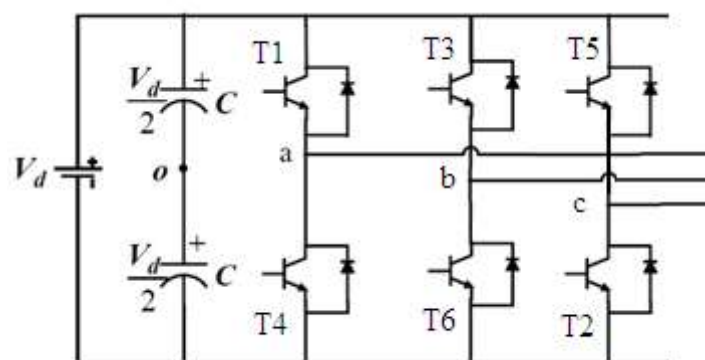

Fig. 3.13: Circuit diagram of Three Phase SPWM VSI

As in single bridge model, the DC component of the line to line voltages is cancelled out between them as shown in Fig. 3.13.

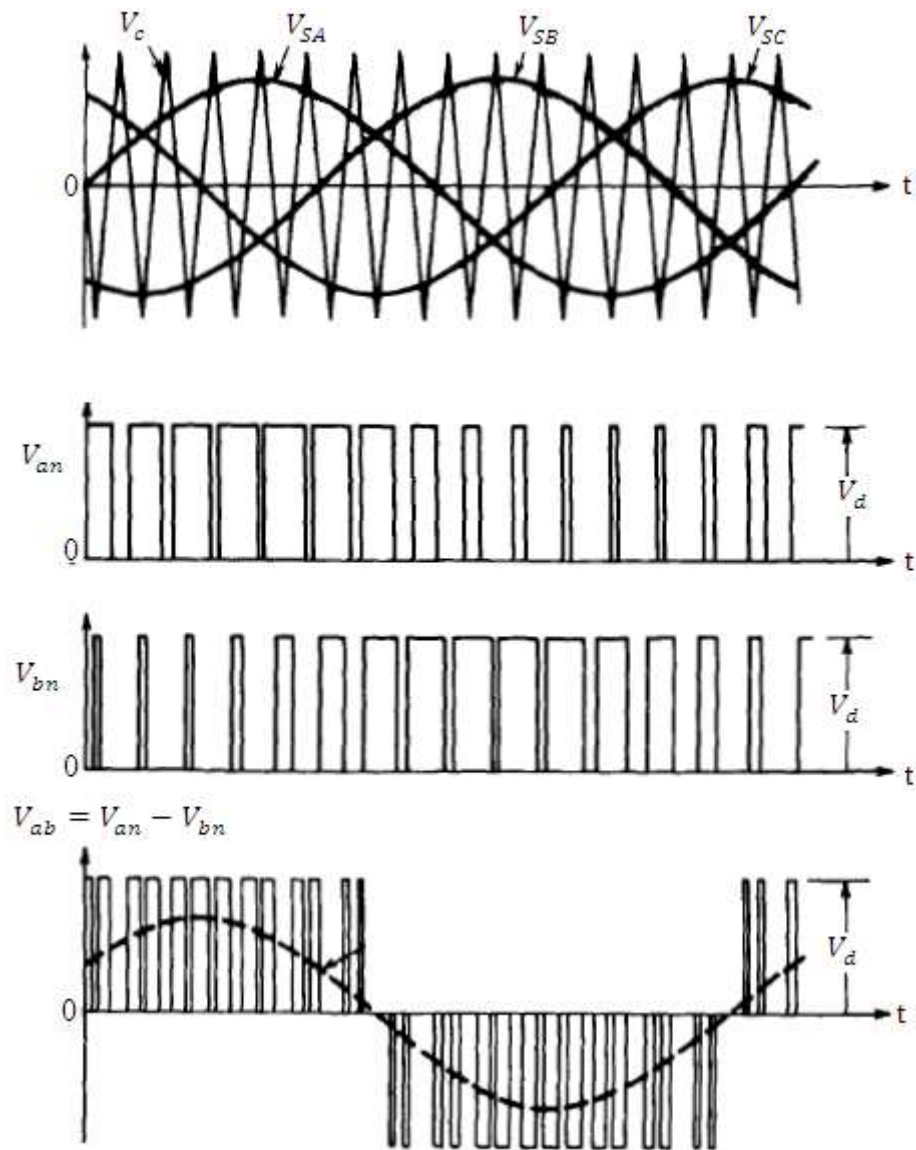

Fig. 3.14: Output wave shapes for the SPWM in three phase VSI <sup>[8]</sup>

Here,  $V_{SA}$  = reference signal from phase A

$V_{SB}$  = reference signal from phase B

$V_{SC}$  = reference signal from phase C

## SIMULATIONS OF GRID INTEGRATION OF RENEWABLE ENERGY USING PWM INVERTER

This chapter will be based on the following topics:

- Simulating the whole system in MATLAB Simulink.
- Analyzing the output wave shapes.

### 4-1 System modeling of Grid Connection:

Fig. 4.1 shows the overall system diagram which consist of three-phase inverter, DC voltage source, and three phase generator acting as the grid. In this configuration the inverter model directly supplies three phase load. <sup>[13]</sup> The three-phase generator supplies the same load through three-phase circuit breaker (CB). When the inverter voltage reaches the steady-state the circuit breaker will close to connect both the inverter and the generator to the same load.

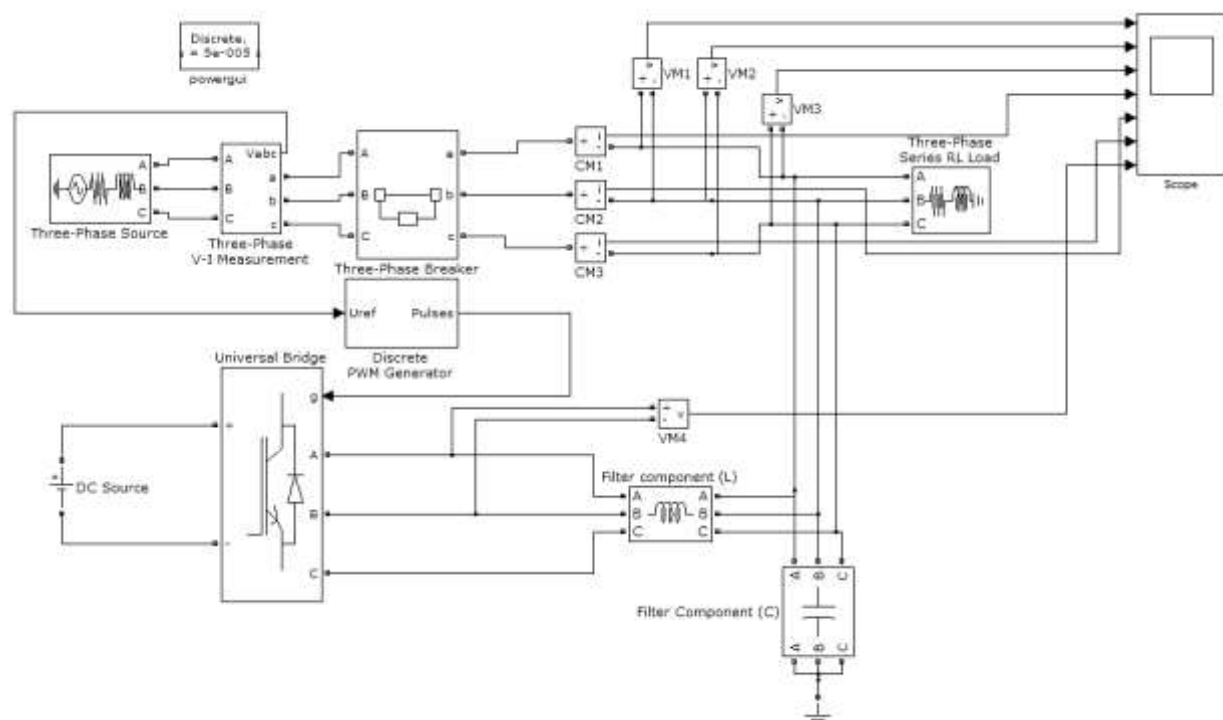

Fig. 4.1: Simulation of Grid Integration of PWM inverted DC source

## 4-2 Simulation Parameters:

The three-phase inverter results obtained with the parameters shown in table 4.1.

Parameter	Value	Unit
DC Source	440	Volt
L filter	1	mH
C filter	100	mF
Frequency	60	Hz
Grid Source	254.034	Volt (rms)
Load Active Power	10	kW
Load Power (Reactive)	100	W

Table 4.1: Simulation parameters of SPWM Inverter

## 4-3 Pulse Width Modulation Modeling:

Look up table was used to save the data in the model. By the equations of harmonics the modeling of PWM generator is shown in Fig.2. In the Fig., the PWM generation for every single leg is shown.

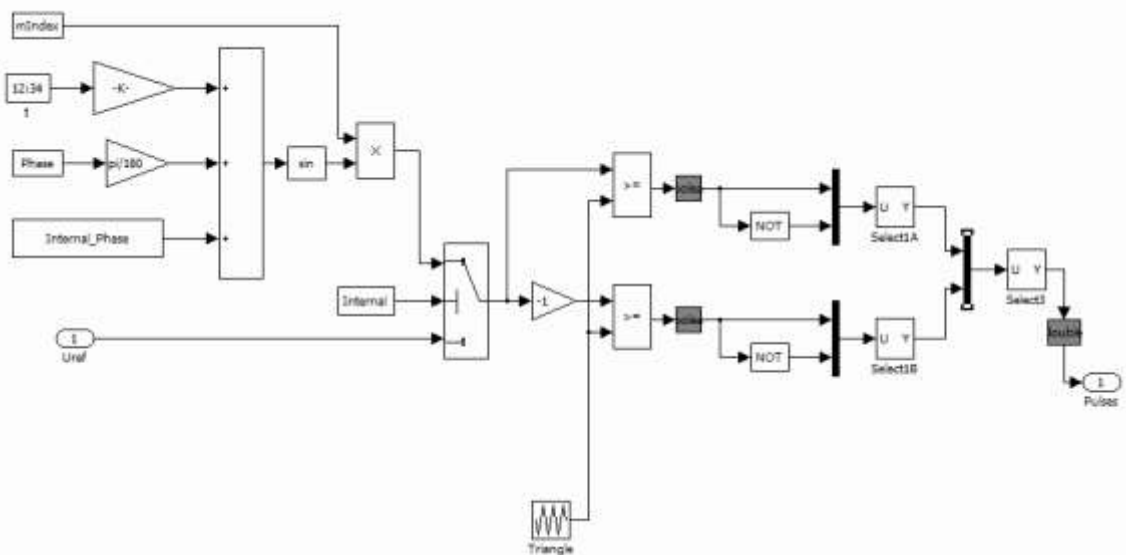

Fig. 4.2: PWM generation model

## 4-4 Simulation Results:

The universal bridge contains 6 IGBT with parallel diodes. For generating PWM, the reference signal was taken from the three phase source by a three phase V-I Measurement.

Reference signal was a triangular signal which was internally generated. The three phase PWM inverted output for the line A-B without the filter is shown below:

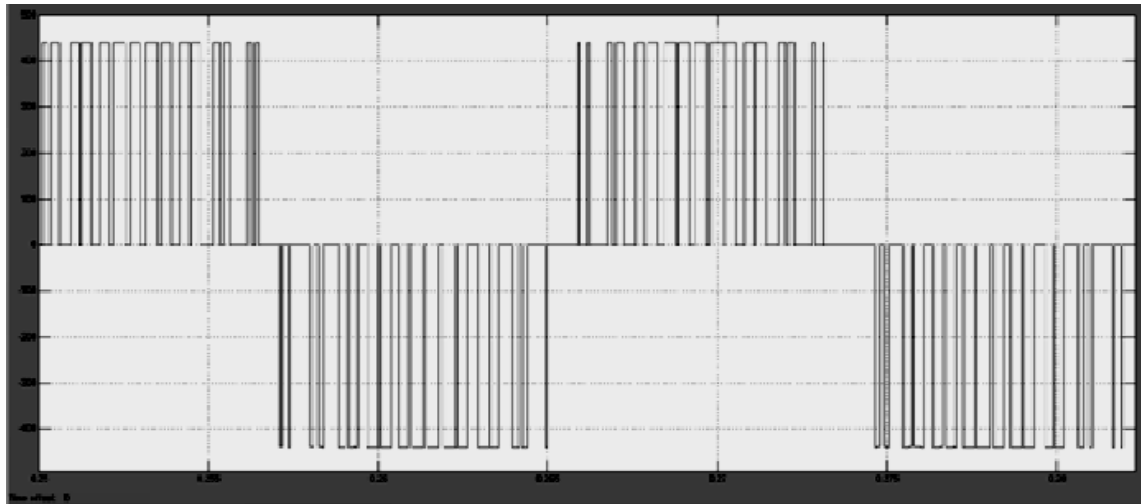

Fig. 4.3: PWM inverted output

After using a low pass L-C filter, the filtered output is shown in Fig. 4. This is approximately a sinusoidal wave with very less harmonics. The filtered output is fed to the grid. High switching frequency is used to reduce the size of the LC filter and the complexity of the inverter. The inverter performance was satisfactory in terms of current and voltage total harmonic distortion (THD) injected to the grid. The filtered output line to line voltage  $V_{AB}$  is shown below:

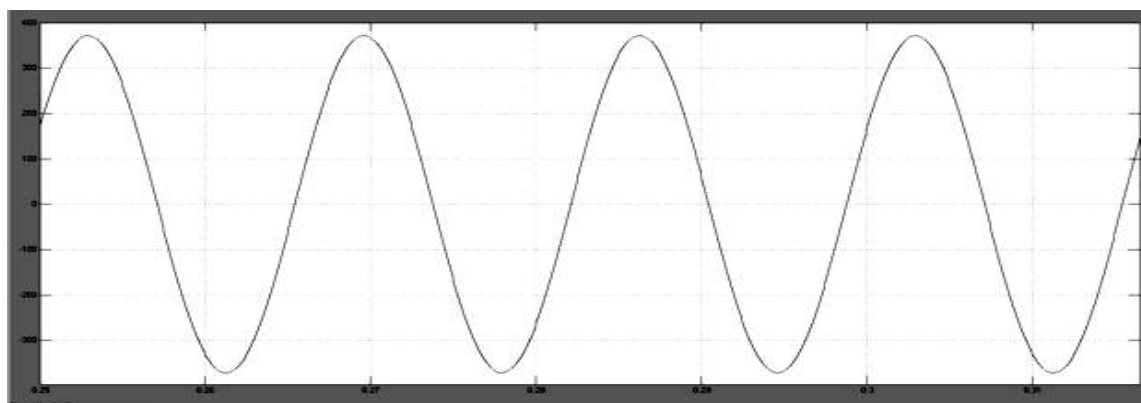

Fig. 4.4: Line to line voltage  $V_{AB}$ , after filtering

When the Circuit Breaker operates with a step input (not shown in Fig.) the three line to line voltages are synchronized with the grid. The output line voltages are given below:

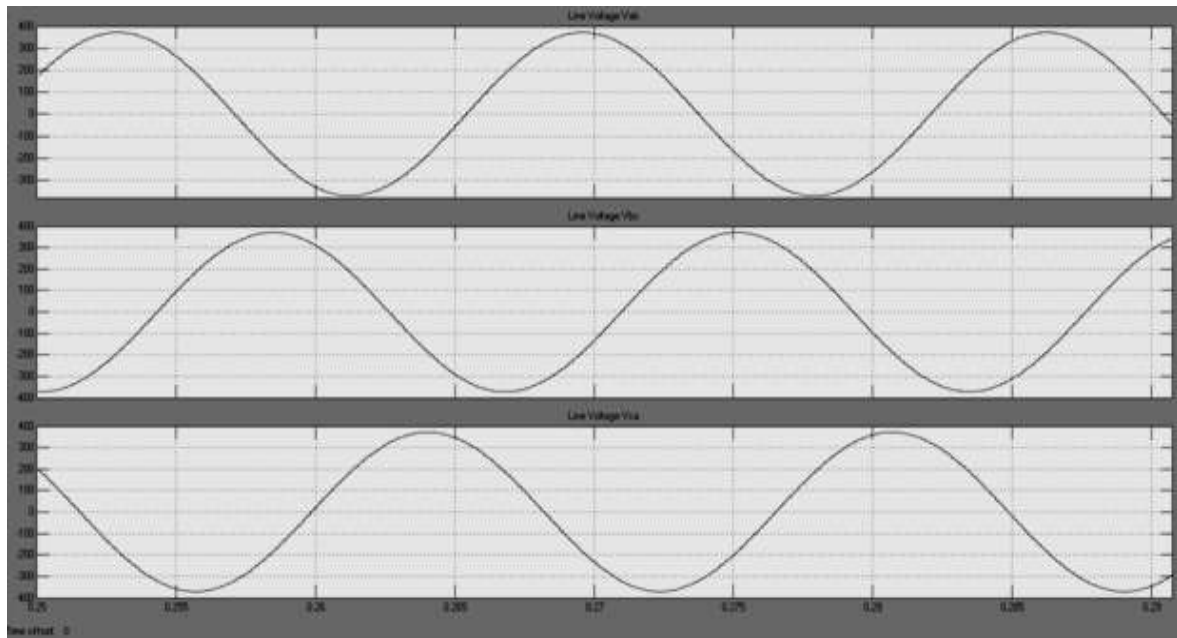

Fig. 4.5: Grid integrated line voltages  $V_{ab}$ ,  $V_{bc}$  &  $V_{ca}$

After integrating the DC source through the inverter to the grid the line currents are reduced from the previous value. The line currents had also less harmonic distortion due to filtering process. The line currents  $I_a$ ,  $I_b$ ,  $I_c$  are shown in Fig. 4.6 below:

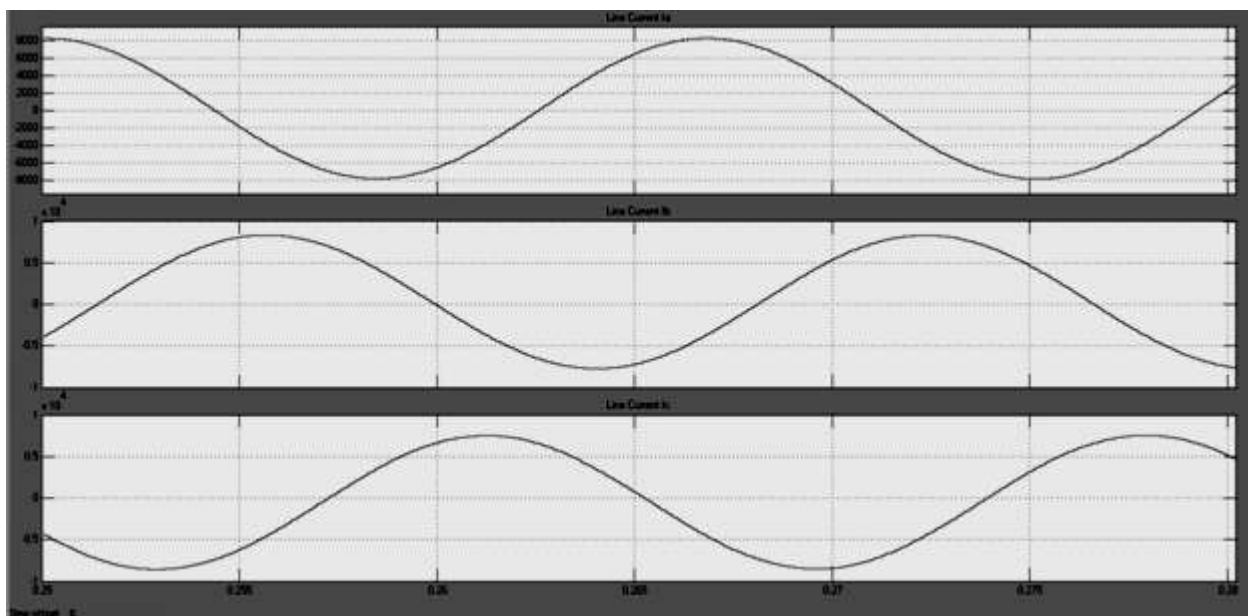

Fig. 4.6: Line currents for the system

The combine simulated 3phase synchronized output voltage is shown in Fig. 4.7

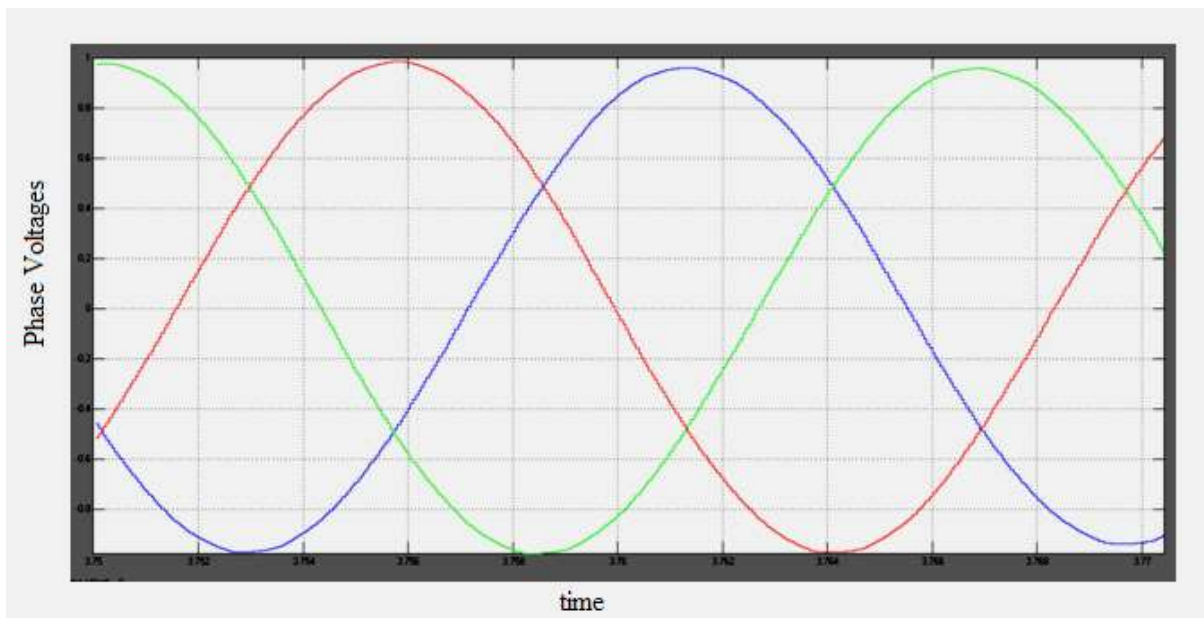

Fig. 4.7 Synchronized Output 3phase Voltages

## Chapter 5

## IMPLEMENTATION

This chapter will contain the following things:

- The total simulated circuit diagram of the SPWM Inverter.
- Description of the different parts of the implemented circuit.
- Outputs of the implemented circuit.

## 5-1 Circuit Diagrams

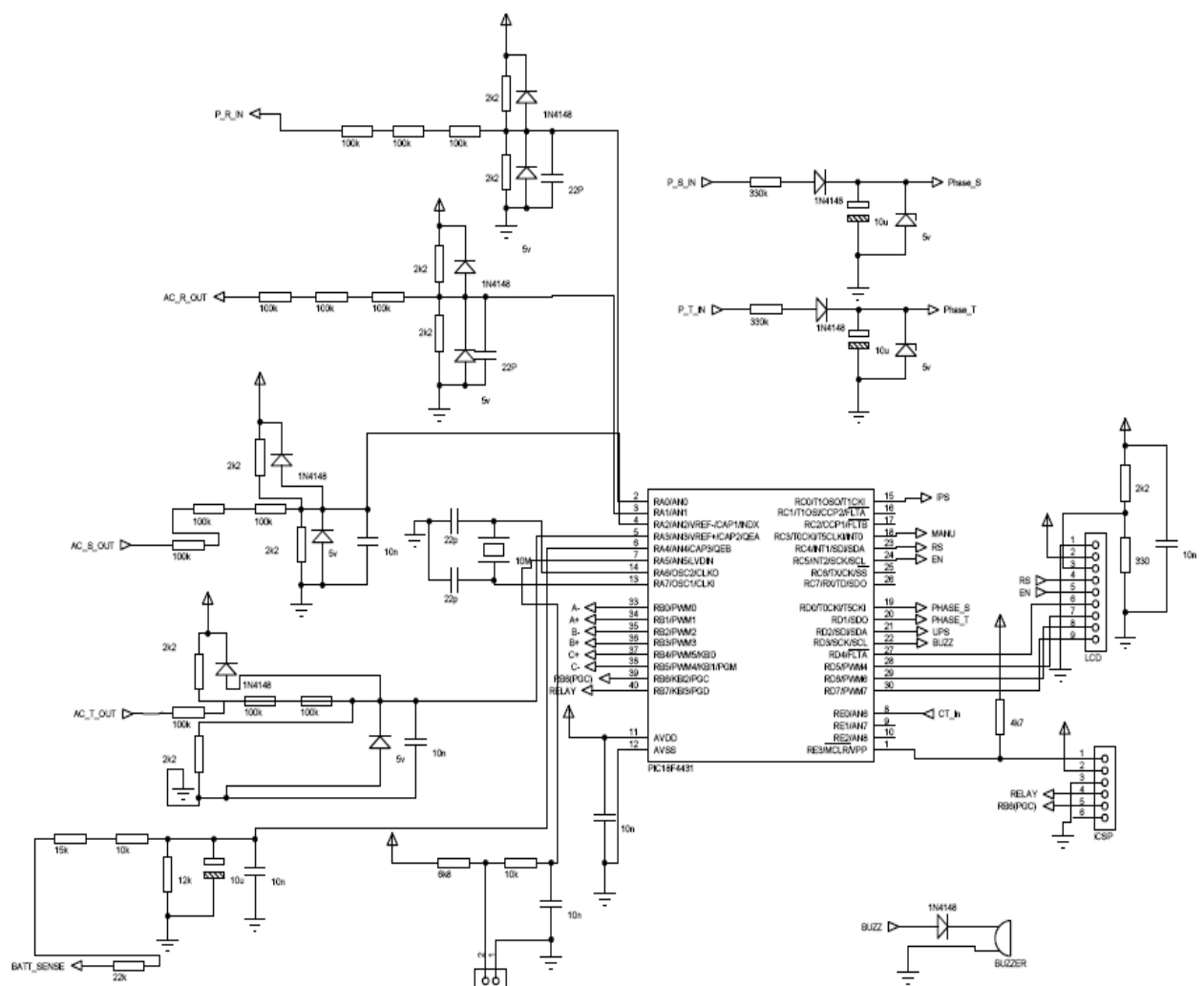



Now, for the better outcome of synchronism, we used serial port LCD display which shows the line voltage with the frequency. The microcontroller encoded the line voltage and frequency. By zero crossing detection it measures the frequency of the line and by sampling and multiplying with the form factor displays the line voltage. The circuit diagram is shown in Fig. 5.3

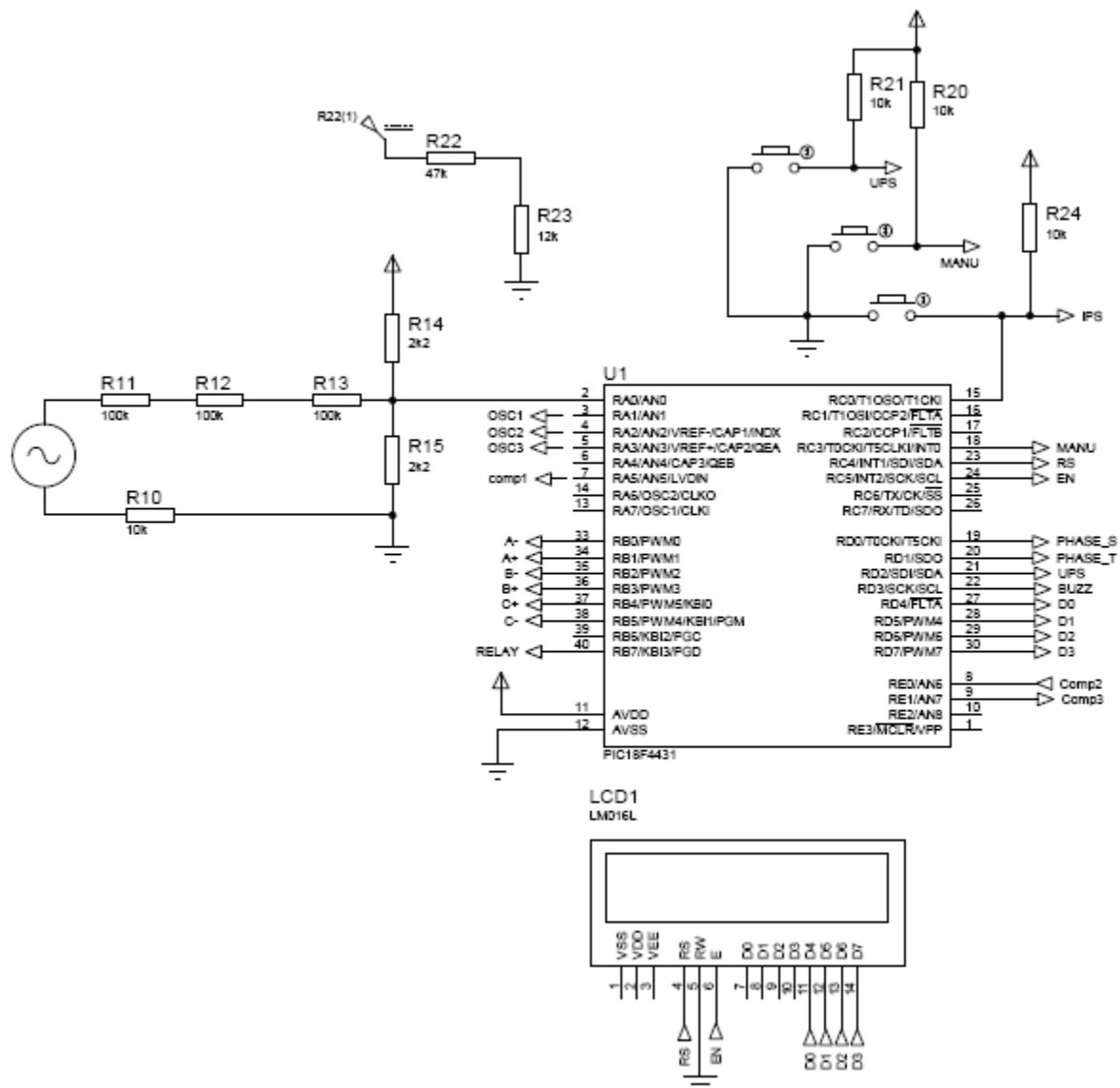

Fig. 5.3 Serial port LCD display circuit

For implementing the circuit practically we made a 3D view of the whole system in Proteus which is shown in Fig. 5.4

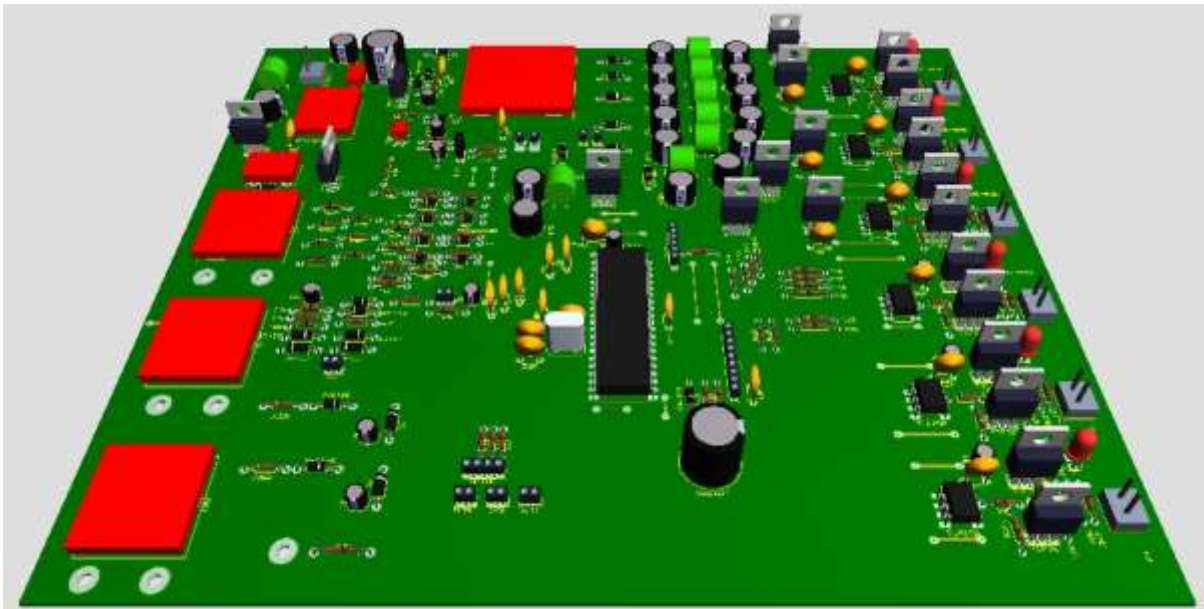

Fig. 5.4: 3D view of the whole system

## 5-2 Practical Implementation

The whole arrangement of the inverter is shown below in Fig. 5.5 with the input DC voltage of 48Volt from the lab module.



Fig. 5.5: Arrangement of the whole system

The switching-mode power supply SMPS circuit is given in Fig. 5.6 which supplies the isolated power with fixed DC voltages by using 7805 and 7815 voltage regulators for the purpose of supply of driver ICs and microcontroller.



Fig. 5.6: SMPS Circuit

To drive the MOSFETs, we used 6 driver ICs-TLP250 with two npn and pnp transistor TIP31 and TIP32 for the amplification purpose with each driver IC. This is shown in Fig. 5.7



Figure 5.7: Driving Circuit

The switching board and LCD display is shown in Fig. 5.8. By the switching board the mod amplitude of the output can be varied by varying the modulation index. The main function of the switch board is to on the inverter module.



Fig. 5.8: Switching Board and LCD display

Now, we used 12 MOSFETs IRFP460 with the rating of 500Volt, 20A. For every leg 4 MOSFETs were used. Two MOSFETs used for every pulse. We did this two increase the

capability of the MOSFETs. The inverter module with low pass filter and the DC bus is shown in Fig. 5.9. Also we used a step up 3phase  $\Delta/Y$  transformer, which converts the 48Volt phase voltage to 220Volt phase to line voltage.

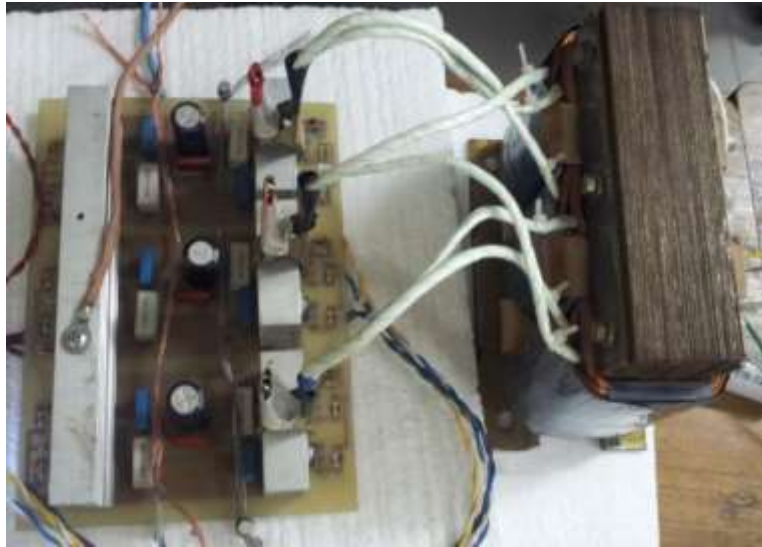

Fig. 5.9 Inverter Legs and step up transformer

### 5-3 Outputs of the Project

---

The output from the inverter is shown in Fig. 5.10 (Phase A). Output rms voltage is 223Volt ac, 50Hz.

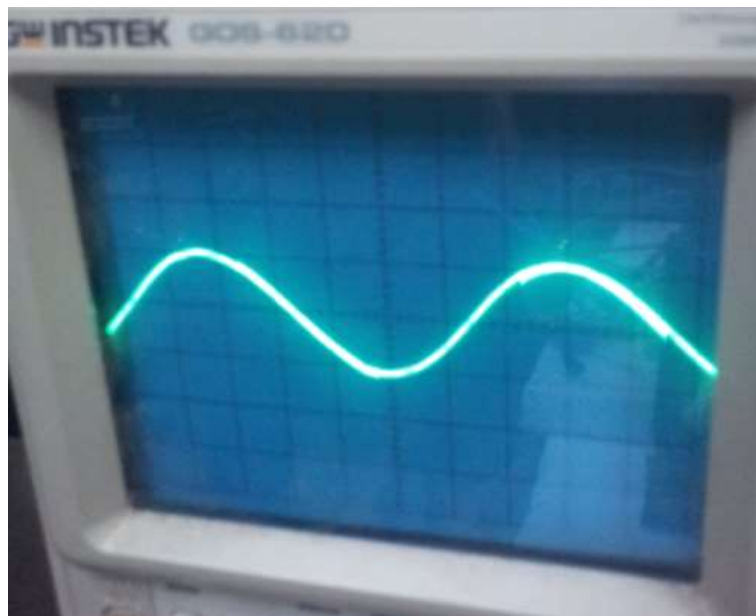

Fig. 5.10 SPWM Inverter Output

Line voltage 223 Volt ac, 50Hz (Phase A) when the inverter was switched off is shown in Fig. 5.11.

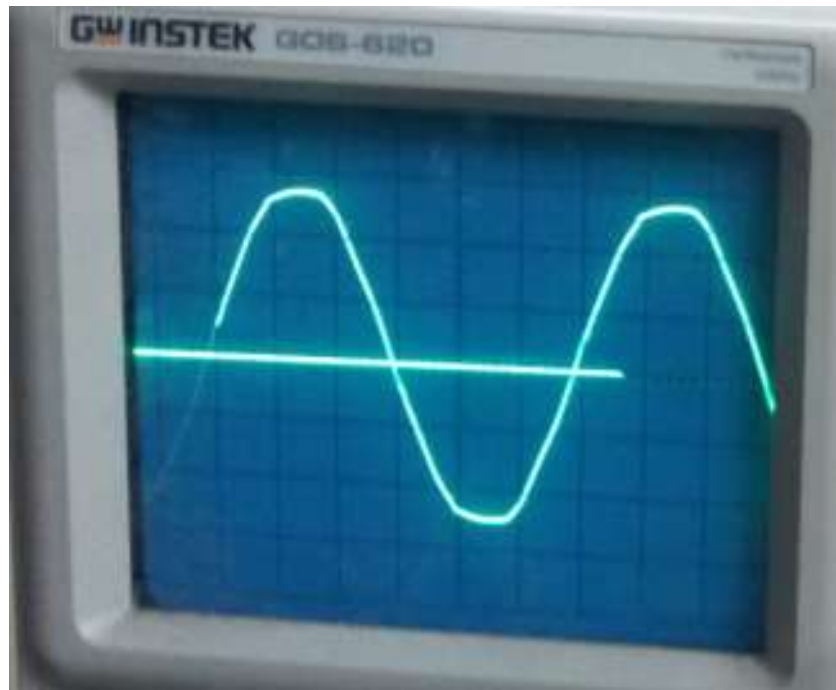

Fig. 5.11 Line Voltage Wave shape

Now, the synchronized output of the inverter with the line is in phase (Phase A) is shown in Fig. 5.12.

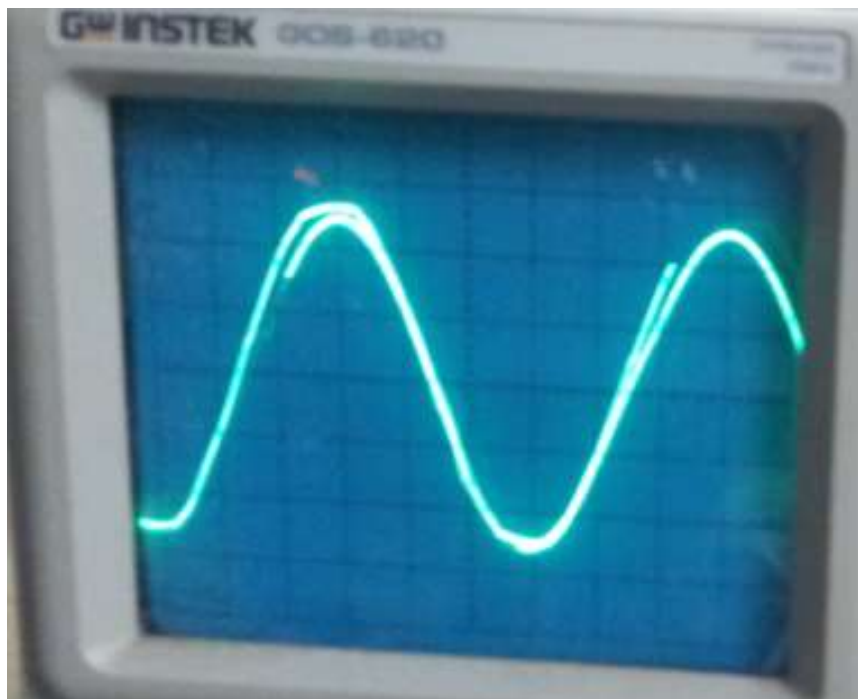

Fig. 5.12: Synchronized Output

Now, in Fig. 5.13, the SPWM output is shown with modulation index 1. The upper portion shows the pulse for the upper MOSFETs (Phase A), that is for the positive and the

lower portion shows the pulse for lower MOSFET, which is for the negative. It is clear from the Fig. that, the output is inverted for the negative one with respect to the positive one.

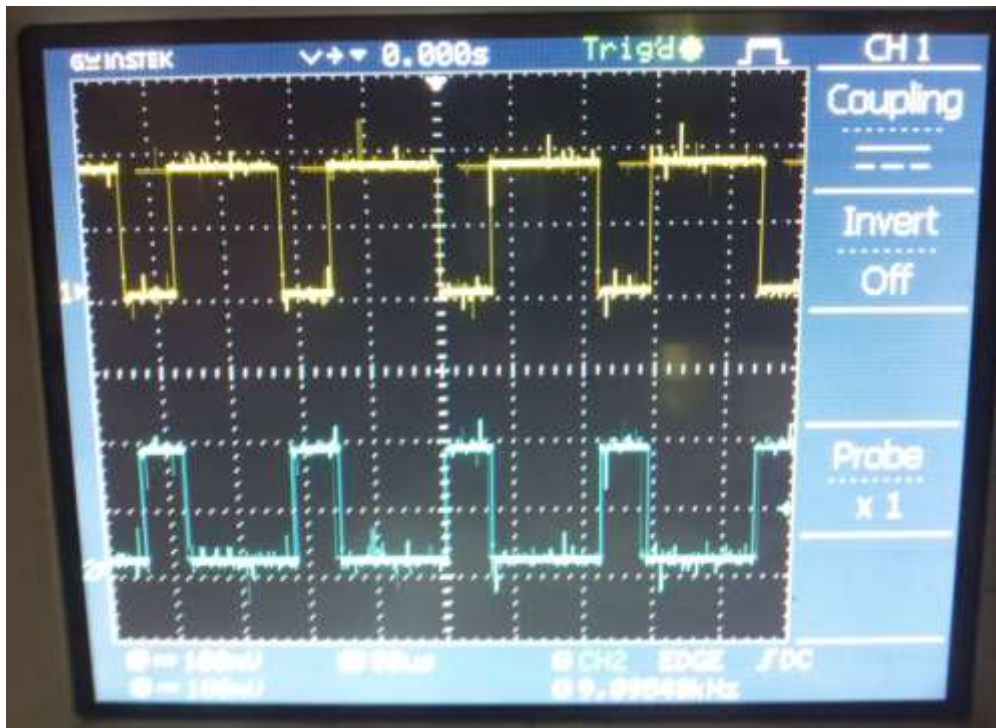

Fig. 5.13: SPWM output

**CONCLUSION****6-1 Discussion on the output**

The main task of this project is to synchronize the output from the pulse width modulated inverter to the grid by integrating. The renewable energy sources such as wind, solar energy etc. are the input which is the variable DC sources and by converting through the converter to a fixed DC source, the output of the converter is fed to the inverter. We only used a fixed DC source as an input to the inverter instead of the previous parts of the DC source as our main part is the pwm inverter. Firstly, we got the sine wave for the pwm inverter on oscilloscope and then this sine wave had been matched with the main line supply sine wave for synchronization. We increased or decreased the amplitude, width etc. to match the two sine waves by microcontroller based switch. We also adjusted the value of the pwm inverter sine wave to the value of the main line supply nearly 220 V to 230 V as obtained from the LCD display connected to the SMPS (Switching Mode Power Supply) circuit. We also observed the output for the pulse given for each MOSFET to the ground which was bipolar and to obtain the output the reference sinusoidal signal is compared with the triangular signal delivered by the microcontroller chip. We implemented the microcontroller program on PIC18F-4431. The program is given in Appendix-IV.

**6-2 Future Work**

In this project, we used the grid signal as a reference signal to the pwm inverter to synchronize the output for grid integration. But now-a-days, load shedding is one of the great problems in Asia especially in Bangladesh. As a result, we are much behind from the development with the developed country. Electricity is a vital thing in every sectors of the technology and it is not expectable to the lack of electricity at desired moment. As we want a continuous flow of electricity in every scientific and technological field, so we kept a scope to fulfill this desired task through the grid integration of renewable energy. Since the conventional power supply is based upon the heavy use of the resources and due to the lack of enough resources or the expensive instruments instead of the power electronics devices, the load shedding is now a common phenomenon across the country. It affects on the economical development of a country and it is totally not desirable. So to overcome this

problem, we have a scope of future implementation, where we may use further implementation and research analysis instead of the reference signal from the grid. We may implement the circuit such that the pwm inverter will continue its synchronization using the internal reference sinusoidal signal when the grid fails due to the load shedding or due to any internal or external faults. As a result, the inverter will be able to supply the continue power flow using the renewable energy resources even during the interruption of the main supply. If we get more scope then it will be a helpful project for the greater betterment of the country and will open a tremendous era in the world of electrical fields.

### **6-3 Limitations**

---

This project is not beyond the limitations. Although we tried our best to provide a best result within the limitations and we hope this project can be implemented more precisely in near future because of the tremendous development of the power electronics filed as well as electrical field. The limitations we faced during the project are described below:

1. First of all, we faced the problem is that the lack of the instruments or elements within the flexible area. Since this project contains most of the power electronics devices, so there were a little concerned regarding the availability of the devices.
2. Due to the unavailability of the devices, most of the instruments or elements had been ordered through the courier service from the out of the local area.

### **6-4 Final comment**

---

We tried our best to implement the project which will carry a great motive regarding the utilization of the renewable energy resources using the power electronics devices to reach the electricity throughout our country within the limited resources. We think that, we will be able to lead our country into the global development if we work together and we create a sound mentality to utilize our remaining resources for the next generation.

▣ REFERENCES ▣

- [1] Md. Habib Ullah, Tamzidul Hoque, Md Musaddaql Hasib, “Current Status of Renewable Energy Sector in Bangladesh and a Proposed Grid Connected Hybrid Renewable Energy System”, *International Journal of Advanced Renewable Energy Research*, et al., Vol. 1, Issue. 11, pp. 618-627, 2012.
- [2] Renewable energy projects, IDCOL solar energy program, (2012, March). URL: <http://www.idcol.org/prjshsm2004.php>.
- [3] M. M. Hasan, M.F. Khan, “A comparative study on installation of solar PV system for grid and non grid rural areas of Bangladesh”, *Developments in Renewable Energy Technology (ICDRET)*, 2012.
- [4] National Institute of Standards and Technology, US Dept. of Commerce, NIST Framework and Roadmap for Smart Grid Interoperability Standards, Release 1.0 (draft), Jan. 2010.
- [5] Grid integration of renewable energy sources P. Kammer, A. Kober BTU Cottbus ; Cottbus, Germany
- [6] DC to DC Conversion: Boost Converter Design Bryan R. Reemmer Team 5 March 30, 2007
- [7] Muhammad H. Rashid, “Power Electronics, Circuits, Devices and Applications”, 3<sup>rd</sup> edition. Pearson Education India, 2003.
- [8] Ned Mohan, Tore M. Undeland, William P Robinson, “Power Electronics, Converter, Design and Application”, 2<sup>nd</sup> edition. Minnesota, Norway-1989.
- [9] J. Holtz, “Pulse width modulation for electronic power conversion”, *Proc. IEEE*, vol. 82, pp. 1194–1214, Aug. 1994.
- [10] Frangos, C. Control System Analysis of a Hardware-in-the-Loop Simulation. *Aerospace and Electronic Systems*, IEEE Transactions on, Volume 26, Issue 4, July 1990 Page(s):666 – 669.
- [11] Jaycar Electronics Reference Data Sheet: Inverter.pdf, Jaycar Electronics, 2000. URL: [http://www.jaycar.com.au/images\\_uploaded/inverter.pdf](http://www.jaycar.com.au/images_uploaded/inverter.pdf).
- [12] M.A.A. Younis, N. A. Rahim, “S. Mekhilef, Simulation of Grid Connected THIPWM Three-Phase Inverter Using SIMULINK”, 2011 IEEE Symposium on Industrial Electronics and Applications (ISIEA2011), September 25-28, 2011, Langkawi, Malaysia.
- [13] Md. Jahidul Alam, Tareq Hossen, Banaful Paul, Rabiul Islam, “Modified Sinusoidal Voltage & Frequency Control of Microgrid in Island Mode Operation” *International Journal of Scientific & Engineering Research* Volume 4, Issue 2, February-2013

- [14] Nahid-ur-rahman Chowdhury, Syed Enam Reza, Tofael Ahmed Nitol, Abd-al-fattah Ibne Mahbub, 'Present Scenerio of Renewable Energy in Bangladesh and a proposed hybrid system to minimize power crisis in remote areas', International Journal for Renewable Energy Research, Vol. 2, 2012.
- [15] Muhammad Saad Rahman, 'Buck Converter Design Issues', Master Thesis performed in Division of Electronic Devices, Linköping Institute of Technology, July'2007.

## APPENDIX-I

### ▣ Microcontroller

In this project we used PIC18F4431 device for microcontroller program input. The PIC18 microcontroller has high computational performance at an economical price, with the addition of high endurance enhanced Flash program memory and a high speed 10-bit A/D converter. The special peripherals include:

1. 14 bit resolution power control PWM module (PCPWM) with programmable Dead-time Insertion.
2. Motion Feedback Module (MFM), including a 3-Channel Input Capture (IC) module and Quadrature Encoder Interface.
3. High speed 10-bit A/D Converter (HSADC)

### ▣ Pin Diagram

The PIC18F4431 can have 16 Kbytes of flash memory and can store up to 8,192 single word instructions.

#### 40-Pin PDIP

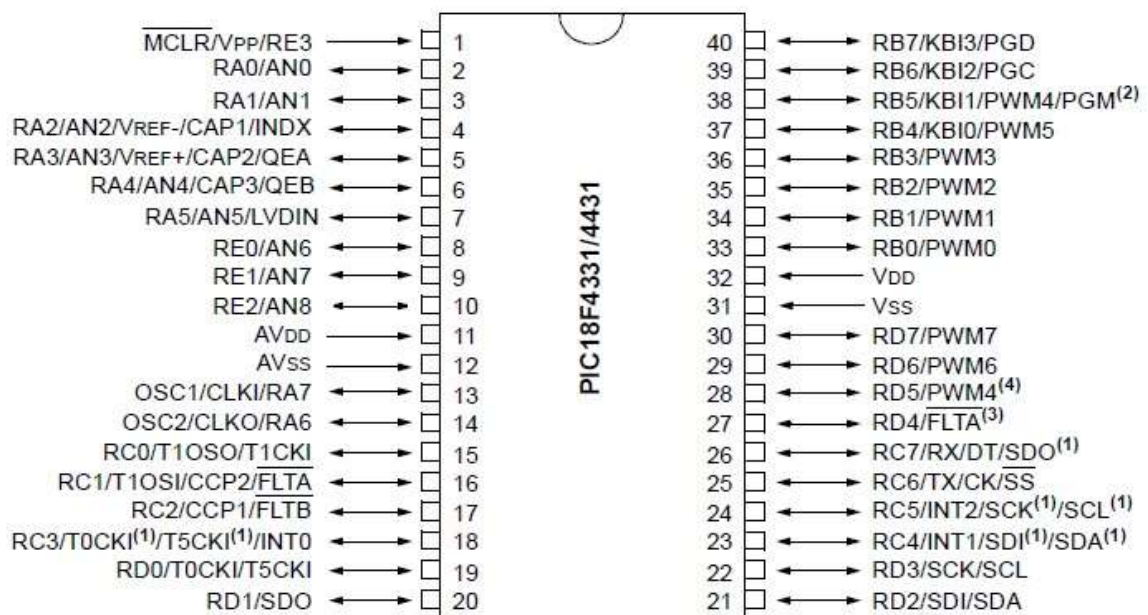

## Pin out I/O Description

Pin Number	Pin Name	Descriptions
1	$\overline{\text{MCLR}}$ /VPP/RE3 $\overline{\text{MCLR}}$ / VPP RE3	Master Clear (input) or programming voltage (input). Master Clear (Reset) input. This pin is an active-low Reset to the device. Programming voltage input. Digital input. Available only when $\overline{\text{MCLR}}$ is disabled.
2	RA0/AN0 RA0 AN0	PORTA is a bidirectional I/O port. Digital I/O. Analog input 0.
3	RA1/AN1 RA1 AN1	Digital I/O. Analog input 1.
4	RA2/AN2/VREF-/CAP1/ INDX RA2 AN2 VREFCAP1 INDX	Digital I/O. Analog input 2. A/D reference voltage (low) input. Input capture pin 1. Quadrature Encoder Interface index input pin.
5	RA3/AN3/VREF+/ CAP2/QEA RA3 AN3 VREF+ CAP2 QEA	Digital I/O. Analog input 3. A/D reference voltage (high) input. Input capture pin 2. Quadrature Encoder Interface channel A input pin.
6	RA4/AN4/CAP3/QEB RA4 AN4 CAP3 QEB	Digital I/O. Analog input 4. Input capture pin 3. Quadrature Encoder Interface channel B input pin.
7	RA5/AN5/LVDIN RA5 AN5 LVDIN	Digital I/O. Analog input 5. Low-Voltage Detect input.
8	RE0/AN6 RE0 AN6	PORTE is a bidirectional I/O port. Digital I/O. Analog input 6.
9	RE1/AN7 RE1 AN7	Digital I/O. Analog input 7.
10	RE2/AN8 RE2 AN8	Digital I/O. Analog input 8.

11,32	VDD	Positive supply for logic and I/O pins.
12,31	VSS	Ground reference for logic and I/O pins.
13	OSC1/CLKI/RA7 OSC1 CLKI RA7	Oscillator crystal or external clock input. Oscillator crystal input or external clock source input. ST buffer when configured in RC mode; CMOS otherwise. External clock source input. Always associated with pin function OSC1. (See related OSC1/CLKI, OSC2/CLKO pins.) General purpose I/O pin.
14	OSC2/CLKO/RA6 OSC2 CLKO RA6	Oscillator crystal or clock output. Oscillator crystal output. Connects to crystal or resonator in Crystal Oscillator mode. In RC mode, OSC2 pin outputs CLKO, which has 1/4 the frequency of OSC1 and denotes the instruction cycle rate. General purpose I/O pin.
15	RC0/T1OSO/T1CKI RC0 T1OSO T1CKI	PORTC is a bidirectional I/O port. Digital I/O. Timer1 oscillator output. Timer1 external clock input.
16	RC1/T1OSI/CCP2/ $\overline{FLTA}$ RC1 T1OSI CCP2 $\overline{FLTA}$	Digital I/O. Timer1 oscillator input. Capture 2 input, Compare 2 output, PWM2 output. Fault interrupt input pin.
17	RC2/CCP1/ $\overline{FLTB}$ RC2 CCP1 $\overline{FLTB}$	Digital I/O. Capture 1 input/Compare 1 output/PWM1 output. Fault interrupt input pin.
18	RC3/T0CKI/T5CKI/ INT0 RC3 T0CKI(1) T5CKI(1) INT0	Digital I/O. Timer0 alternate clock input. Timer5 alternate clock input. External interrupt 0.
19	RD0/T0CKI/T5CKI RD0 T0CKI T5CKI	PORTD is a bidirectional I/O port. Digital I/O. Timer0 external clock input. Timer5 input clock.
20	RD1/SDO RD1 SDO	Digital I/O. SPI data out.
21	RD2/SDI/SDA	Digital I/O.

	RD2 SDI SDA	SPI data in. I2C. data I/O.
22	RD3/SCK/SCL RD3 SCK SCL	Digital I/O. Synchronous serial clock input/output for SPI mode. Synchronous serial clock input/output for I <sup>2</sup> C mode.
23	RC4/INT1/SDI/SDA RC4 INT1 SDI(1) SDA(1)	Digital I/O. External interrupt 1. SPI data in. I2C. data I/O.
24	RC5/INT2/SCK/SCL RC5 INT2 SCK(1) SCL(1)	Digital I/O. External interrupt 2. Synchronous serial clock input/output for SPI mode. Synchronous serial clock input/output for I <sup>2</sup> C mode.
25	RC6/TX/CK/ $\overline{SS}$ RC6 TX CK $\overline{SS}$	Digital I/O. EUSART asynchronous transmit. EUSART synchronous clock (see related RX/DT). SPI slave select input.
26	RC7/RX/DT/SDO RC7 RX DT SDO	Digital I/O. EUSART asynchronous receive. EUSART synchronous data (see related TX/CK). SPI data out.
27	RD4/ $\overline{FLTA}$ RD4 $\overline{FLTA}$ (2)	Digital I/O. Fault interrupt input pin.
28	RD5/PWM4 RD5 PWM4(3)	Digital I/O. PWM output 4.
29	RD6/PWM6 RD6 PWM6	Digital I/O. PWM output 6.
30	RD7/PWM7 RD7 PWM7	Digital I/O. PWM output 7.
33	RB0/PWM0 RB0 PWM0	PORTB is a bidirectional I/O port. PORTB can be software Programmed for internal weak pull-ups on all inputs. Digital I/O. PWM output 0.
34	RB1/PWM1 RB1 PWM1	Digital I/O. PWM output 1.

35	RB2/PWM2 RB2 PWM2	Digital I/O. PWM output 2.
36	RB3/PWM3 RB3 PWM3	Digital I/O. PWM output 3.
37	RB4/KBI0/PWM5 RB4 KBI0 PWM5	Digital I/O. Interrupt-on-change pin. PWM output 5.
38	RB5/KBI1/PWM4/ PGM RB5 KBI1 PWM4 PGM	Digital I/O. Interrupt-on-change pin. PWM output 4. Low-Voltage ICSP. Programming entry pin.
39	RB6/KBI2/PGC RB6 KBI2 PGC	Digital I/O. Interrupt-on-change pin. In-Circuit Debugger and ICSP programming clock pin.
40	RB7/KBI3/PGD RB7 KBI3 PGD	Digital I/O. Interrupt-on-change pin. In-Circuit Debugger and ICSP programming data pin.

## APPENDIX-II

### ▣ Driver IC TLP250

Features: Transistor inverter, Inverter for Air Conditioner, IGBT gate drive, Power MOSFET gate drive.

This unit is 8-lead DIP package.

TLP250 is suitable for gate driving circuit of IGBT or power MOS FET.

- Input threshold current:  $I_F=5 \text{ mA(max.)}$
- Supply current (ICC):  $11 \text{ mA(max.)}$   
Supply voltage (VCC):  $10\text{--}35\text{V}$   
Output current (IO):  $\pm 1.5\text{A (max.)}$
- Switching time (tpLH/tpHL):  $1.5 \mu\text{s(max.)}$
- Isolation voltage:  $2500\text{Vrms(min.)}$
- Option (D4) type
- Maximum operating insulation voltage:  $630\text{V}_{\text{PK}}$
- Highest permissible over voltage:  $4000\text{V}_{\text{PK}}$

## ▣ Schematic arrangement

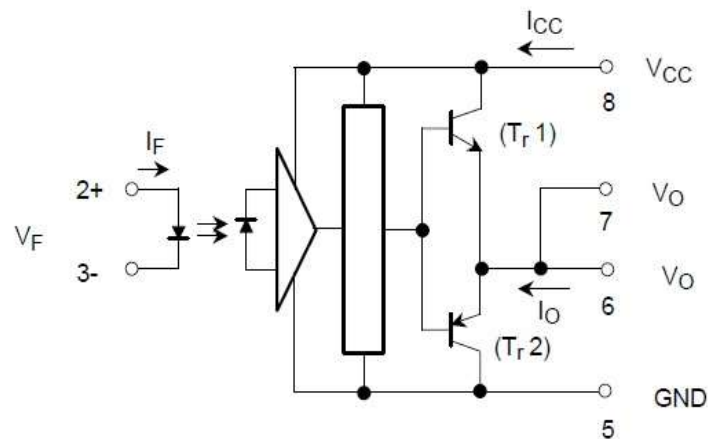

## ▣ Pin Configuration

1. N.C. (Not Connected)
2. Anode
3. Cathode
4. N.C. (Not Connected)
5. GND (Ground)
6. Vo (output)
7. Vo
8. Vcc

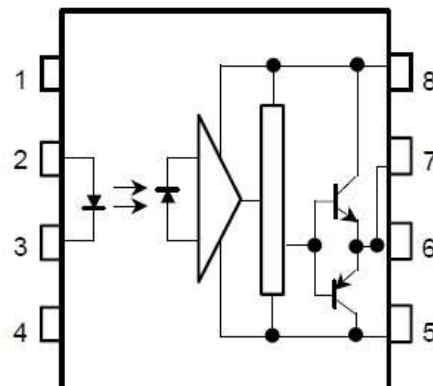

## APPENDIX-III

### ▣ N-channel Power MOSFET IRFP460

Type	$V_{DSS}$	$R_{DS(on)}$	$I_D$
IRFP460	500 V	<0.27 $\Omega$	20 A

- Typical  $R_{DS(on)} = 0.22 \Omega$
- Extremely high  $dv/dt$  capability
- 100% avalanche tested
- Very low intrinsic capacitances
- Gate charge minimized

Symbol	Parameter	Value	Unit
$V_{DS}$	Drain-Source Voltage( $V_{GS}=0$ )	500	V
$V_{DGR}$	Drain-gate voltage( $R_{GS}=20 \text{ k}\Omega$ )	500	V
$V_{GS}$	Gate-source Voltage	$\pm 20$	V
$I_D$	Drain current(continuous) at $T_c=25 \text{ }^\circ\text{C}$	20	A
$I_D$	Drain current(continuous) at $T_c=100$ $^\circ\text{C}$	13	A
$I_{DM}(.)$	Drain current (pulsed)	80	A
$P_{tot}$	Total dissipation at $T_c=25 \text{ }^\circ\text{C}$	250	W
$dV/dt$	Peak diode recovery voltage slope	3.5	V/ns
$T_{stg}$	Storage temperature	-65 to 150	$^\circ\text{C}$
$T_j$	Maximum operating junction temperature	150	$^\circ\text{C}$

(.) Pulse width limited by safe operating area

### ▢ Schematic Arrangement and Photograph of IRFP460

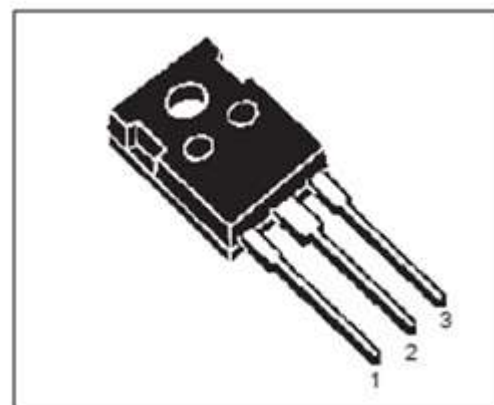
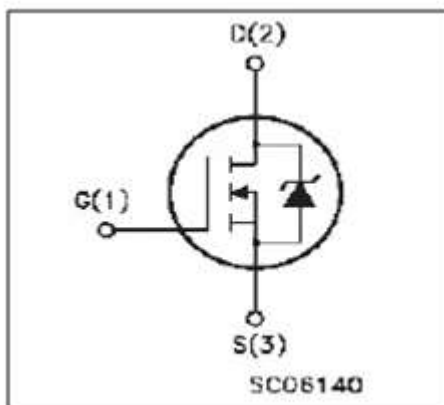

## APPENDIX-IV

### Microcontroller Program

---

```

Device = 18F4431
XTAL   = 40.00

LCD_INTERFACE 4
LCD_RSPIN PORTC.4
LCD_ENPIN PORTC.5
LCD_DTPIN PORTD.4
REMINDERS = OFF
RESERVE_RAM 127
REMINDERS = On
Include "Basic_int.inc"
Include "Init_Symbol.inc";
Include "Manu_Set.bas"
DelayMS 100
Dim Phase           As Bit
Dim Fire            As Bit
Dim chk_zr          As Bit
Dim Manu            As Bit
Dim Do_buzz         As Bit
Dim Right           As Bit
Dim Left            As Bit
Dim Get_Back        As Bit
Dim inc_Pwm         As Bit
Dim Dec_Pwm         As Bit
Dim test As Word
Dim i               As Byte
Dim Gen_Count       As Word
Dim INDEX           As Byte
Dim INDEX2          As Byte
Dim INDEX3          As Byte
Dim INDAcI          As Byte
Dim SinePwm1        As DWord
Dim SinePwm2        As DWord
Dim SinePwm3        As DWord
Dim AcVolt          As Word
Dim AcScle          As Word
Dim j               As Byte
Dim Power_Command As Word
Dim Buzz_Count      As Byte
Dim Sref            As Byte
Dim Disp            As Byte
Dim Disp_Count      As Byte
Dim Ac_IN           As Word
Dim AC_R_Out        As Word
Dim Ac_S_Out        As Word
Dim Ac_T_Out        As Word
Dim Batt_in         As Word
Dim Load            As Word
Dim Temp_in         As Word
Dim DCoffset        As Word
Dim Sub_Manu_No_1  As Byte
Dim BattNumbers     As Byte

```

```

Dim ShowAc           As Word
Dim AC_S_Volt       As Word
Dim AC_T_Volt       As Word
Dim BttHighCut      As Word
Dim BttLowCut       As Word
Dim nothing         As Word
Dim BttVarYLowCut   As Word
Dim BTNVAR          As Byte
Dim Ol_Limit        As Word
Dim BattRef         As Word
Dim Chg_Limit       As Word
Dim Manu_No         As DWord
Dim Batt_Volt       As DWord
Dim CompOffertR     As Byte
Dim CompOffertS     As Byte
Dim CompOffertT     As Byte
Dim AcInArray[30]  As Word
Dim AcOutArray[30] As Word
Dim LoadArray[30]  As Word
On_Interrupt GoTo ISR
On_Low_Interrupt GoTo ISR_LOW

GoTo Initialize
ISR:
SYSTEM_SAVE
ASM
    bcf    GIE
    btfsc TMR0IF
    bra    TMR0_INT
    bra    EXIT_INT1
ENDASM
TMR0_INT:
    bcf TMR0IF           ;clear the interrupt flag
    movlw 158           ;load Timer0 Offset
    movwf TMR0L,0
    ADCHS = %00000000
    ADCON0.1=1
    If Fire = 1 Then GoTo UpDate_Duty :
    Else : GoTo Shut_Down
UpDate_Duty:
    High Relay
    OVDCOND =%00111111      ;Override Polarity
    OVDCONS =%00000000;
    Sref = LRead8 SINETABLE[INDEX]
    SinePwm1 = Power_Command + CompOffertR      ;Adding Offset To
Calibration R
    SinePwm1 = (SinePwm1 * Sref ) >> 8      ;Multiply And Scle
power
    SinePwm1 = SinePwm1 + 20

    PDC0L = SinePwm1
    PDC0H = SinePwm1h
    Sref = LRead8 SINETABLE[INDEX3]
    SinePwm2 = Power_Command + CompOffertS      ;Adding Offset To
Calibration S
    SinePwm2 = (Power_Command * Sref ) >> 8 ;Multiply And Scle
power
    SinePwm2 = SinePwm2 + 20

```

```

PDC1L = SinePwm2
PDC1H = SinePwm2h
Sref = LRead8 SINETABLE[INDEX2]
SinePwm3 = Power_Command + CompOffertT ;Adding Offset To
Calibration T
SinePwm3 = (Power_Command * Sref) >> 8 ;Multiply And Scle
power
SinePwm3 = SinePwm3 + 20

PDC2L = SinePwm3
PDC2H = SinePwm3h
GoTo Updated

```

Shut\_Down:

```

Low Relay
OVDCOND =%00000000 ;All Pwms are inactive
OVDCONS =%00010101 ;All Odd Pwms are Grounded

GoTo Updated

```

Updated:

```

Inc INDEX ;Incremanting Index of sine array
Inc INDEX2
Inc INDEX3

If INDEX = 60 Then
    INDEX = 0
If inc_Pwm = 1 And Power_Command < 2200 Then Power_Command =
Power_Command + 4
If Dec_Pwm = 1 And Power_Command > 22 Then Power_Command =
Power_Command - 4
EndIf

If INDEX2 = 60 Then INDEX2 = 0
If INDEX3 = 60 Then INDEX3 = 0
EXIT_INT1:
If INDACI = 30 Then INDACI = 0
Inc Gen_Count

```

SYSTEM\_RESTORE

ISR\_LOW:

```

If ADIF = 1 Then
    ADIF = 0

```

Initialize:

```

GIE = 1
PEIE = 1
ADIF = 0
i = 0
AC_S_Volt = 0
Low PORTB
INDEX = 0
INDEX2 = 20
INDEX3 = 40
Phase = 0
Power_Command = 21
Fire = 0
AC_R_Out = 0

```

```
DCoffset      = 502
Get_Back      = 0
Manu          = 0
BTNVAR        = 0
inc_Pwm       = 0
Dec_Pwm       = 0

    For i = 0 To 20
        Toggle Buzz
        DelayMS 100
    Next i

Low Buzz
Cls
DelayMS 200
TMR0ON        = 1 'Timer0 On
GoTo Main

CONFIG_START
OSC = HSPLL ; HS OSC Enabled
FCMEN = OFF ; Disabled
IESO = OFF ; Disabled
PWRTEN = On ; Enabled
BOREN = On ; Enabled
BORV = 20 ; 2.0V
WDTEN = OFF ; Disabled
WINEN = OFF ; Disabled
WDPS = 32768 ; 1:32768
T1OSCMX = OFF ; Active
HPOL = High ; Active high
LPOL = High ; Active high
PWMPIN = OFF ; Disabled
MCLRE = OFF ; Disabled
STVREN = OFF ; Disabled
LVP = OFF ; Disabled
Debug = OFF ; Disabled
CP0 = On ; Disabled
CP1 = On ; Disabled
CPB = OFF ; Disabled
CPD = On ; Enabled
WRT0 = OFF ; Disabled
WRT1 = OFF ; Disabled
WRTB = OFF ; Disabled
WRTC = OFF ; Disabled
WRTD = OFF ; Disabled
EBTR0 = OFF ; Disabled
EBTR1 = OFF ; Disabled
EBTRB = OFF ; Disabled
CONFIG_END
```